



# FLAME SAFEGUARD FOR BURNER MANAGEMENT SYSTEMS

Year 2000 Compliant in accordance with BSI document DISC PD2000-I:1998

---

## APPLICATION

The 25SU3 Model 4169T control and associated flame scanner(s) (Type 45UV5, 45RM1, 45RM2, 45RM4, 45UVFS1 and 45FS1) operate in combination with suitable auxiliary equipment to provide ignition and flame failure detection for manual, semi-automatic, or fully automatic ignited fuel burners. The 4169T control is designed for single or multiple burner applications firing gas, oil, pulverized coal, or other combustibles.

---

## DESCRIPTION

This modular self-checking unit is a solid state control for flame failure protection, repeatedly checking the overall performance of the flame monitoring system several times per minute. The self-checking function is obtained by a magnetically driven shutter which periodically cuts off the flame radiation to the scanner for a short interval. If any component from the scanner sensor to the Flame Relay becomes defective, the Flame Relay is de-energized and an alarm results so that corrective measures may be taken. If a flame failure occurs, the control system sounds an alarm and de-energizes the fuel valves in less than 1 second (This time can be increased by external capacitor).

The 45UV5 scanner employs a gas discharge type detector which responds only to a portion of the ultra-violet spectrum where there is characteristic radiation from common fuel flames. The detector and its associated power transformer and shutter are enclosed in an aluminum enclosure employing high temperature sealing gaskets and a quartz viewing lens. The lens is a plano-convex lens which increases the scanner's sensitivity by up to 400 percent. A hinged mount is provided to permit easy and fast cleaning of the lens when required. A double screw and keyhole slot arrangement permits ready removal of the housing from its mount. The scanner has a 1" tapping for attachment to a threaded sight pipe and has a 3/8" tapping for connection of a sightpipe-purging high pressure air line.

The control is capable of operating two scanners simultaneously. The flame signal outputs may be used separately or connected together to enhance the total signal. Scanners may also be switched (e.g. from Pilot to Main Flame) using only a single pole switching contact.

# DIMENSIONS

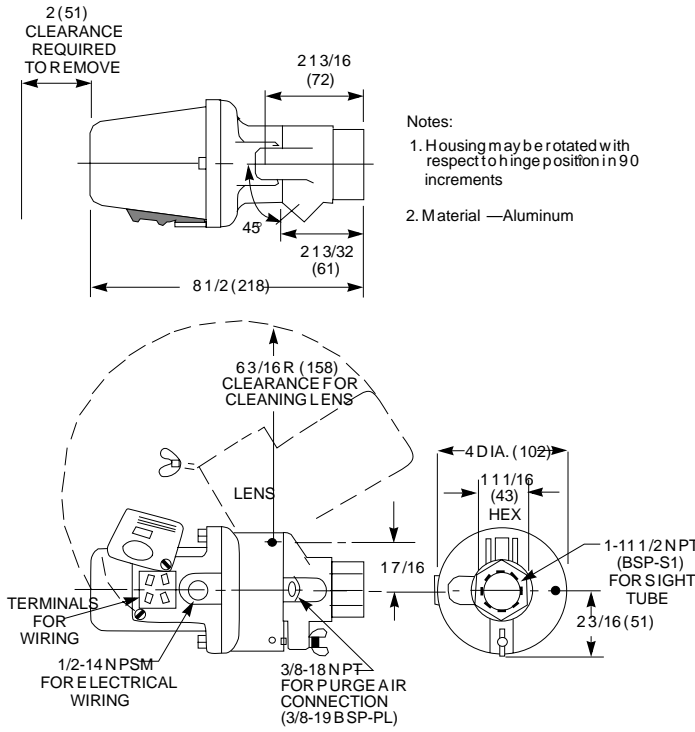

SCANNER TYPE 45UV5-MODEL 1000 (NPT), 1010, 1101

NOTE: When using a 45UV5 scanner:

- 4169T controls with a code lower than 18 require Model 1101.
- 4169T controls currently offered (Code 18 and higher) must be used with model 1000 or 1010.

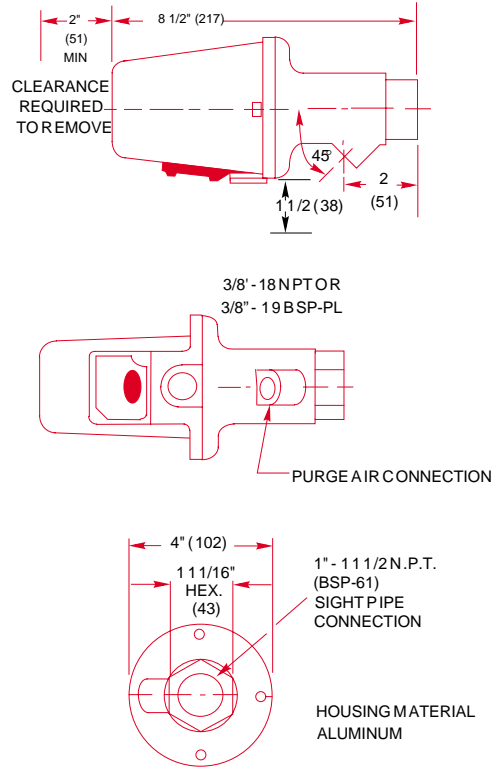

45RM1-MODEL 1001 (NPT), 1003  
45RM2-MODEL 1000 (NPT), 1001

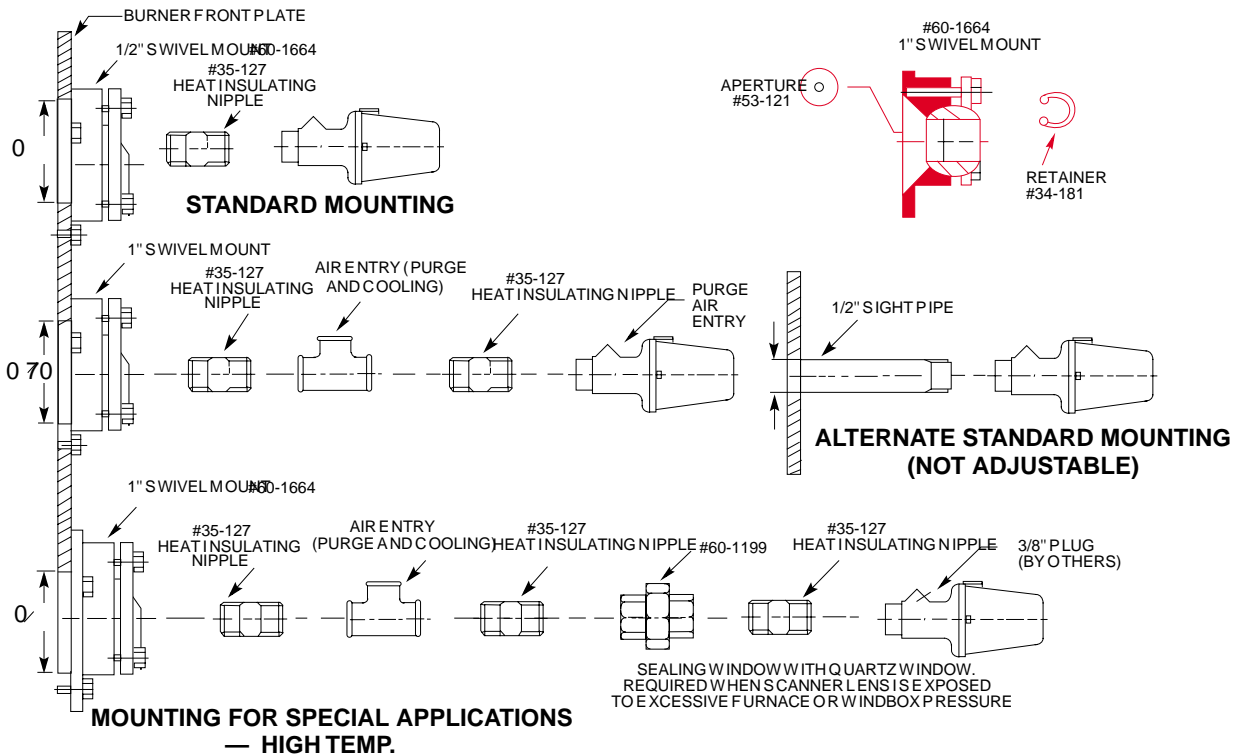

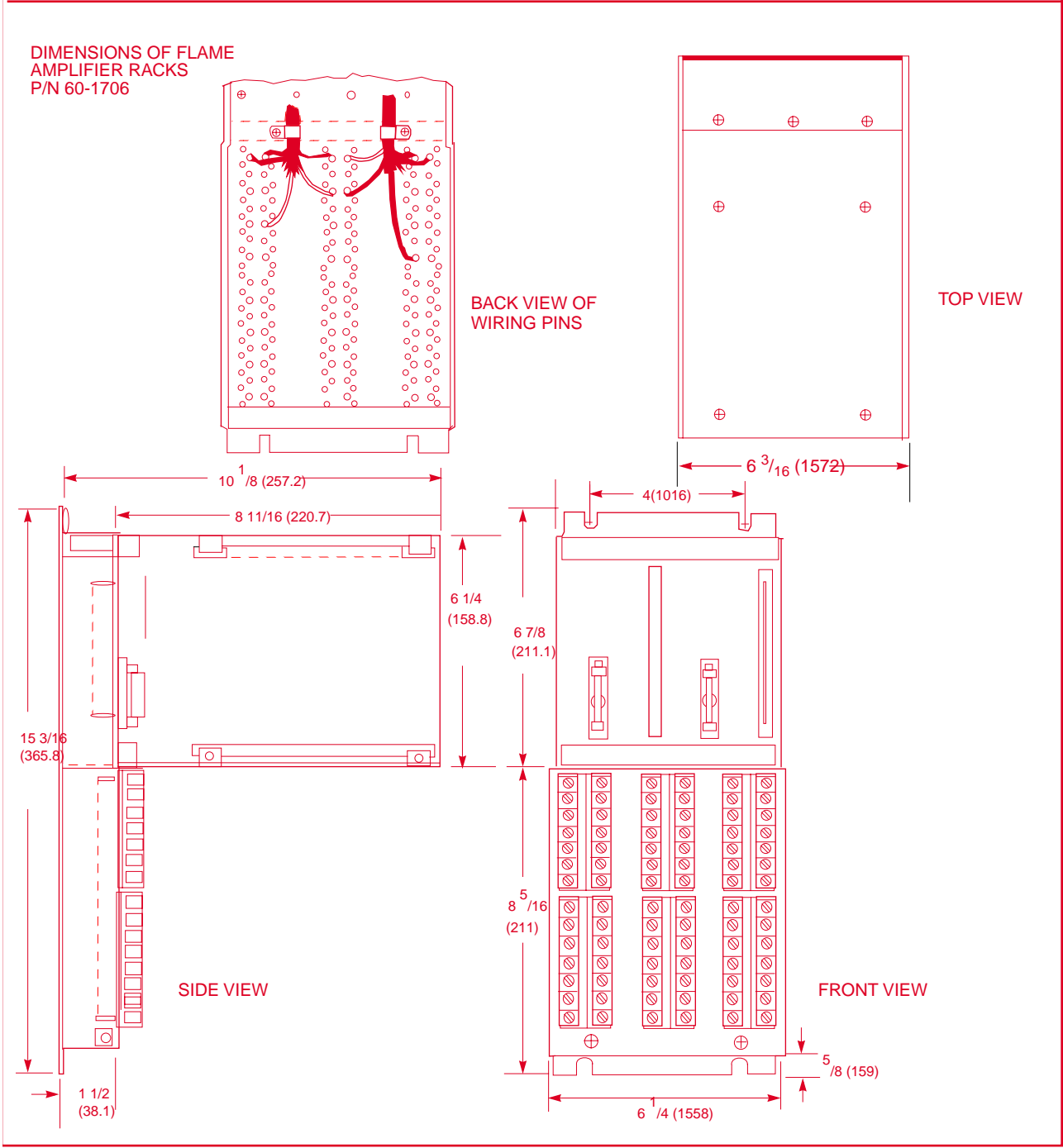
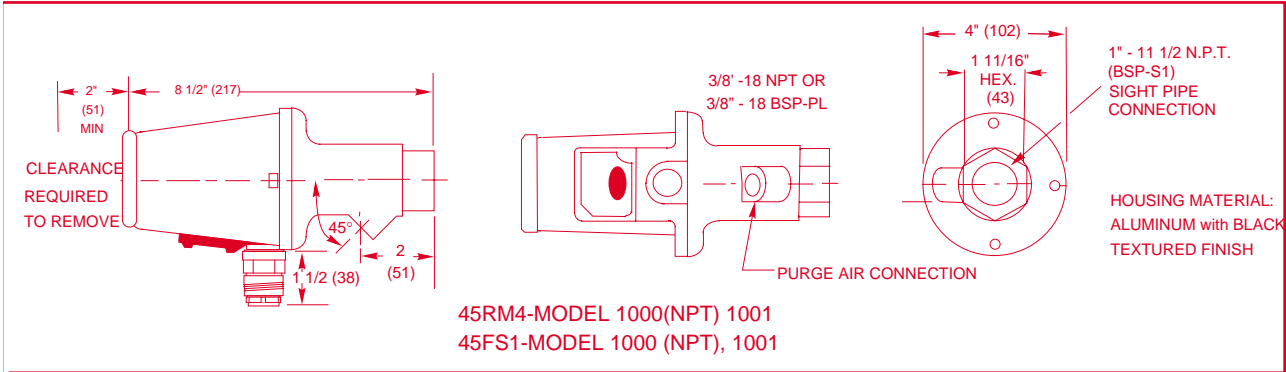



---

## SPECIAL FEATURES

### Marginal Alarm

The marginal alarm is an auxiliary circuit which energizes a relay as long as the flame signal being detected remains above a preset level. (The level is adjustable by a potentiometer on the front panel). An alarm is given if there is a reduction in the indicated flame signal, such as might be caused by dirt on the scanner lens or off-ratio firing, etc. Corrective action in response to the alarm to restore normal burner performance may prevent a burner shutdown. The alarm will automatically reset when the flame returns to normal.

### Sensitivity Controls

The sensitivity of the control in response to flame signals is continuously adjustable over a 64 to 1 ratio by means of a potentiometer having a calibrated logarithmic dial. Each mark on the dial denotes a sensitivity change of 2 to 1. Two such sensitivity controls are provided for dual-fuel or dual-scanner applications with terminals available for activating either control via a remote selector switch.

### Auxiliary Relays

Another feature of this modular control is the versatility of having all contacts of all relays brought out to terminals so that external connections can be chosen to suit the application.

There are also two auxiliary relays RX and RY that can be used for a variety of purposes such as switching sensitivity controls or scanner signals where more than one scanner is used. These relays operate on approximately 25VDC.

### Flame Signal Meter

Included on the front panel of each control is a "Flame Signal Meter" having a calibrated logarithmic scale. This meter gives a continuous check on the intensity of the flame being monitored by the scanner and shows the action of the self-checking mechanism as the shutter repeatedly cuts off the radiation to the detector tube. It is used to monitor adjustments of the sensitivity control and to assist in setting the trip point of the Marginal alarm. Terminals are also available for connecting an additional remote Flame Signal Meter (PN 38-54, 38-55 or 38-81) if desired. Flame signal is also available as a current output, (0 to 20 milliamperes), that matches the 0-3 volt signal of the Flame Signal Meter. The load resistance of the remote current meter or recorder must not be greater than 800 ohms.

---

## SPECIFICATIONS

**Control:** 25SU3 Model 4169T

**Maximum Flame Failure Response Time (FFRT):** 1 sec. (4 with external capacitor).

**Nominal shutter total cycle period:** 5.5 seconds.

**Supply Voltage:** 24VDC (21.6 min., 28.8 max.).

**Scanner:** Refer to Pages 2 and 3.

**Power Input:** (With normal supply voltage and no loads connected to relay contacts)

Control with 1 or 2 scanners: 0.5A.

Inrush current at turn on (with 1 or 2 scanners): 10A instantaneous peak.

**Relay Ratings (Max.) All models:**

Normally open contacts of all relays: 230/120 VAC, 100 VA resistive;  
30VA Pilot Duty, 28VDC resistive, 1 ampere.

Normally closed contact of all relays: 230/120 VAC, 50VA resistive;  
15VA pilot duty, 28 VDC resistive, 0.5 ampere.

RX, RY coil ratings: 24VDC±15%, 3000 ohms.

**Operating Temperature:**

**25SU3 Control:** 71° C max., 0° C min., ambient.

**45UV5 Scanner:** 100° C max., -40° C min. at housing flange.



**45RM, 45RM2, and 45RM4 Scanner:** 65° C max., -40° C min. at housing flange  
45FS1 Scanner: 65° C min. at housing flange.

**Storage Temperature:** Scanner and control: 85° C max., -40° C min.

**Position of Control (Operating):** Unlimited

**Shipping Weights:**

25SU3	2.3 kg	45RM2	1.2 kg
45UV5	1.8 kg	45RM4	1.2 kg
45RM1	1.2 kg	45FS1, 45UVFS1	1.2 kg

*Note: Weights shown do not apply to fiber optic scanner*

**Mounting Rack:** 60-1706 5.4 kg

## ORDERING INFORMATION

**Control:** Type 25SU3 Model 4169T (24VDC)

**Mounting Rack:** 60-1706

**UV Tube:** Type 4-320-1

**Connection cable:** Type 59-221

**Swivel Mount Adaptor:** Type 60-1664-4

**Heat Insulator:** 35-127-3

**Quartz lens union coupling (for 45UV5):** Type 60-1199

**Extended lens assembly (for 45RM1, 45RM2, 45RM4, 45FS1):** Type 60-1622

**Flame signal meter:** Type 38-55

### WHEN USING A 45UV5 SCANNER:

1. 4169T controls having a code lower than 18 require Model 45UV5-**1101**.
2. 4169T controls currently offered (code 18 and higher) must be used with models 45UV5-**1000** or 45UV5-**1010**.

### Electrical Rating Considerations

The relay contact ratings of the 25SU3 controls are based on normal circuit current in amperes multiplied by nominal circuit voltage, called volt-amperes and abbreviated as VA.

VA Pilot duty rating permits the connection of relays, solenoid valves, indicator lamps, and other electrical devices under the condition that normal operating VA may not exceed the rating. Inrush VA may not exceed ten times the rating.

The term “Inrush” as applied here relates ordinarily to a device wherein a part of the magnetic structure is free to assume two defined positions (such as a solenoid plunger) and signifies the current which flows in the short interval between energizing of the coil and seating of the movable structure in its energized position. The term also relates to resistive devices which operate at incandescent temperatures (such as a lamp) where the cold resistance is much less than the hot resistance and where accordingly the current during the short interval between energizing and incandescence is considerably higher than normal operating current.

Ratings as they affect the contacts within the Fireye control are established on the assumption that no contact will be required to carry inrush currents more often than once in fifteen seconds. The use of limit, interlock, or operating control switches that do not make positive contact at closure and which give rise to “chattering” of relays within the Fireye controls or devices energized through it may lead to premature failure of switching members in the control. Similarly, the contacts cannot be expected to handle short-circuit currents without possible damage. It is therefore of vital importance to make a “dry run” check of the control system (with manual fuel shut-off valves closed) following the automatic opening of a control system fuse or circuit breaker, or following any known instance of relay or switch chattering!



## Testing and Adjustment Procedure

1. Turn the selected sensitivity controls to 64.
2. Establish the flame at the operating level.
3. Observe the Flame Signal Meter.
4. If the reading is off scale, decrease the sensitivity until the reading is on scale.
5. Choose a sensitivity setting which meets the minimum requirements of the following section entitled "Flame Signal."

*Example: If it is desired to adjust the control for reliable hold-in but to no greater sensitivity than necessary, as in multiple burner installations, use the minimum setting dictated by paragraph below.*

After determining this setting, the margin over the interfering burner may be found as follows:

1. Turn off the "wanted" burner.
2. Increase the sensitivity until the flame relay pulls in due to the "unwanted" burner, then turn it down very slowly until it drops out.
3. The new sensitivity setting compared to the original normal setting is an indication of the degree of discrimination.
4. Return the sensitivity to the determined setting.

FLAME SIGNAL		
SENSITIVITY SETTING	MINIMUM READOUT FOR FLAME DETECTED	MAXIMUM READOUT FOR BACKGROUND
1-8	2	$\frac{1}{4}$
8 - 32	4	$\frac{1}{4}$
32 - Max.	8	$\frac{1}{4}$

**For 45RM4 scanners, refer to Bulletin CU-31 for setup and adjustment.**

**For 45FS1 and 45UVFS1 scanners, refer to Bulletins CU-32 and CU-33 for set up and adjustment.**

## Control and Scanner Wiring

Make wiring connections at terminal strip at the top and bottom of the rack. Follow approved wiring diagrams. Connect bared wires directly to screwposts —or use insulated lugs. Use suitable wire enclosed in rigid or flexible conduit for power connections. All wiring must comply with the National Electrical Code and with local codes. Splices must be made only in troughs or junction boxes.

It is important that cross-phasing be prevented on multiphase installations. The common of all control components (magnetic starter coil, ignition transformer, pilot and main fuel valves, etc.) powered by the control must be connected to the common side of the supply line.

Observe correct polarity of 24 volt supply since wrong polarity will damage control. One side of the 24 volt supply line must be grounded. Grounding the negative terminal is preferred. When positive terminal is grounded and 45RM1 scanner is used, date code on the scanner must be higher than 7840 or short circuit will occur. Each mounting rack must be grounded either by the normal conduit ground or by an added grounding wire.

**Refer to appropriate scanner bulletin for wiring instructions.**

### 25SU3-4169T

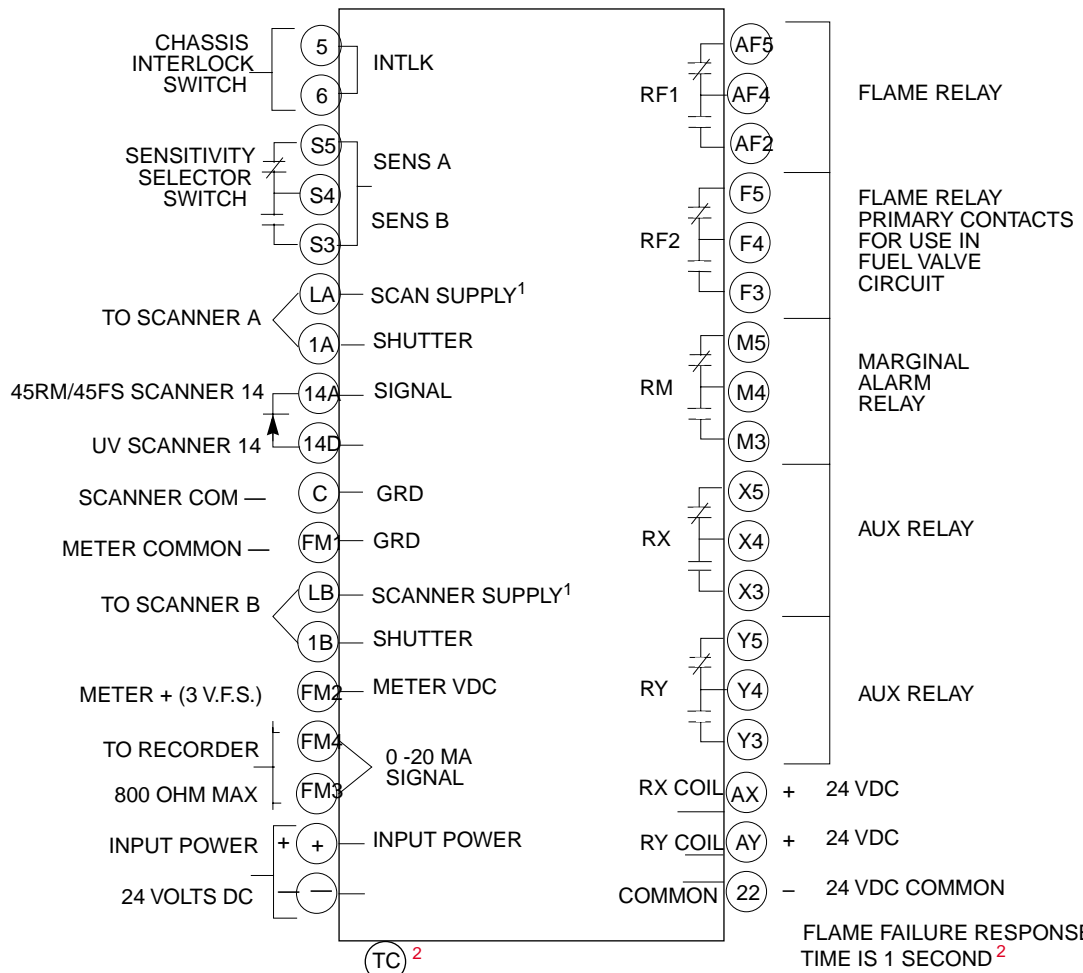

FLAME FAILURE RESPONSE TIME IS 1 SECOND<sup>2</sup>

<sup>1</sup> 45 RM4 and 45FS1, 45UVFS1scanners require +24VDC power supply.

<sup>2</sup>See conversion Note Below.

### WIRING SHOWN IS WITH 60-1706 RACK

### 25SU3-4169 FFRT FIELD CONVERSION

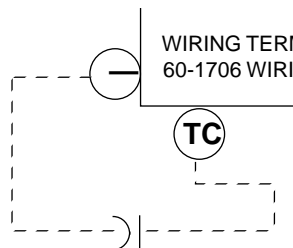

The FFRT for the 4169T as shipped from the factory is 1 second. In order to change this to 3 seconds, install a 300mf capacitor (P/N 7-1040) on terminals as shown on the above diagram. Observe polarity.

In order to change the FFRT to 4 seconds install two of the same capacitor in parallel. Observe polarity.



---

## MAINTENANCE

**HUMIDITY EFFECTS:** It is considered good practice to minimize any possible adverse effects of high humidity by keeping electronic equipment continuously powered, even during periods when it is not in use.

**SCANNER:** If continuous air purging of the scanner sight pipe is not completely effective in preventing viewing window contamination, a schedule should be set up for periodically cleaning the window. Always use a soft, clean (non-oily) cloth to wipe the window. For maximum assurance that oil films will be removed, wash first with a cloth dampened (not dripping) with a concentrated detergent solution.



**CAUTION: DISCONNECT OR SHUT OFF ELECTRIC POWER WHEN WORKING ON SCANNER.**

---

## NOTICE

When Fireeye products are combined with equipment manufactured by others and/or integrated into systems designed or manufactured by others, the Fireeye warranty, as stated in its General Terms and Conditions of Sale, pertains only to the Fireeye products and not to any other equipment or to the combined system or its overall performance.

---

## WARRANTIES

FIREYE guarantees for one year from the date of shipment of its products to replace, or, at its option, to repair any product or part thereof (except lamps, electronic tubes and photocells) which is found defective in material or workmanship or which otherwise fails to conform to the description of the product on the face of its sales order. **THE FOREGOING IS IN LIEU OF ALL OTHER WARRANTIES AND FIREYE MAKES NO WARRANTY OF MERCHANTABILITY OR ANY OTHER WARRANTY, EXPRESS OR IMPLIED.** Except as specifically stated in these general terms and conditions of sale, remedies with respect to any product or part number manufactured or sold by Fireeye shall be limited exclusively to the right to replacement or repair as above provided. In no event shall Fireeye be liable for consequential or special damages of any nature which may arise in connection with such product or part.



FIREYE®  
3 Manchester Road  
Derry, New Hampshire 03038  
<http://www.fireeye.com>

CX-784  
FEBRUARY 1999  
Supersedes August 1993