

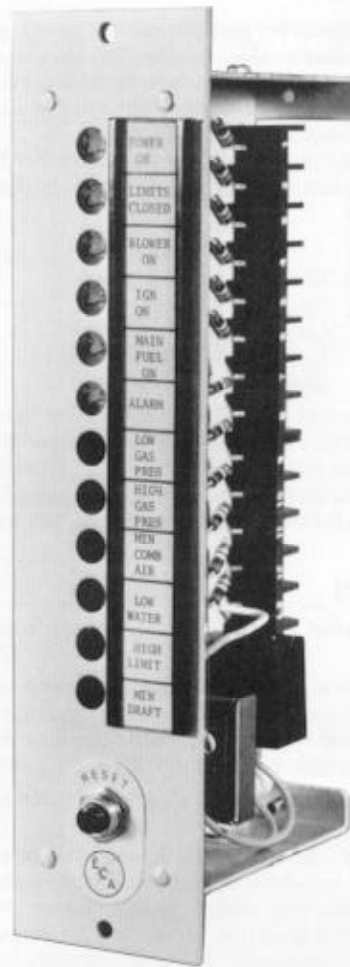

SYSTEM INDICATOR

Type 53SE1 Model 1000



DESCRIPTION

System Indicator Type 53SE1 is a versatile, compact six-point "first out" fault annunciator plus six-point indicator, which monitors the operation of industrial fuel burner systems and industrial processes. The system indicator detects which of six interlock circuits was first opened, reports the information by energizing the corresponding "first out" indicator and the alarm circuit. The red LED indicator and alarm remain powered until the reset button is pressed. The first out annunciator section utilizes solid state electronics for reliability and optical couplers for isolation. It connects directly to the interlock circuit being monitored; separate switches are not required. The unit also contains six status-indicating neon lamps which show the presence of line voltage at any desired point in the system.

The 53SE1 has an attractive brushed aluminum finish, is designed for flush mounting in a panel or cabinet and is gas-

keted. A self-adhesive nameplate strip is provided for the identification of each individual function.

The Problem Solving System Indicator 53SE1 provides operation information and reduces trouble shooting time and expense. The System Indicator can be used with industrial equipment such as:

Fuel burners
Refrigeration systems
Chemical processes
Process furnaces, ovens, kilns
Refineries
Pulp & paper equipment

Food processing
Machine automation
Elevators-conveyors
Printing equipment
Air conditioners
Textile machinery

Contact any of the Field Sales Offices of Electronics Corporation of America for assistance with nonstandard applications. They are listed in the Yellow Pages under "Controls".

Specifications Type 53SE1 Model 1000

Supply: 102 to 132 volts 50/60HZ
Power Consumption: 2 VA (excluding alarm)
Alarm Contact Rating: 125 VA Pd.
First Out Indication: L.E.D. (Red)
Condition Indicators: Long Life Neon

Ambient Limits: +25F (min) 125F (max)
Humidity: 90% noncondensing (max)
Response Speed: 12 milliseconds
Weight: 2 lbs.



ELECTRONICS CORPORATION OF AMERICA

INSTALLATION

The 53SE1 is designed for installation in a panel surface or on the front of a surface enclosure. The unit may be mounted in any position as there are no parts affected by gravity. Total power consumption of the device is less than 2 watts so that very little heat is generated.

Figure 1 shows the mounting dimensions for the 53SE1. A mounting kit is supplied with each unit, containing the following items:

| Item | Qty. | Description |
|------|------|----------------------------|
| 1. | 2 | 10-32 Mounting Screws |
| 2. | 1 | Neoprene Gasket |
| 3. | 1 | Label Holder |
| 4. | 2 | Label Form (3 Labels Each) |
| 5. | 1 | Label Window |

The Neoprene Gasket may be used for sealing between the front plate of the 53SE1 and the panel surface on which it is mounted. It is not necessary to use the gasket if sealing is not required. The plastic nameplate holding strip supplied is furnished with a self-adhesive strip on the back. The nameplate

strip is positioned on the 53SE1 front plate so that the printed label aligns with the indicators. The nameplate information is typed on a label within the printed guidelines, and after typing, the label strip is cut along the printed outline. The protective vinyl window and the typed nameplate strip are both slid into the plastic holder to complete the assembly.

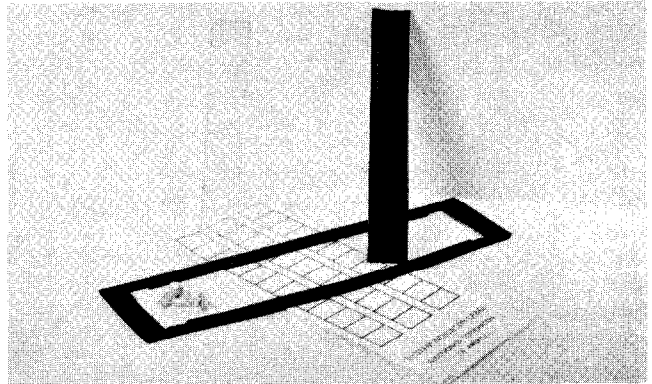

OPERATION

The System Indicator provides an automatic start-up sequence as follows:

1. When power is first applied to the system with interlocks either open or closed, no indication of first out condition is shown. The system will remain in this condition until all of the series interlocks are closed.
2. When all interlocks are closed, a time delay of one second is started.
3. At completion of time delay, the System Indicator is activated. Now any interlock opening will trigger and latch a first out indication and alarm. Manual Reset is required following a first out fault trip. Reset may be accomplished with the reset button on the 53SE1, or remotely by deenergizing the unit.

The purpose of the time delay is to avoid false triggering of the first out detector by bouncing contacts on the last interlock to close. A gating circuit is also used with the voltage comparators that detect the first out condition so that voltage comparison is only done at the peak of alternate half cycles of the AC supply line. This provides a very high level of rejection of spurious noise and voltage transients that are present on the supply line. The condition indicators are illuminated any time they are powered.

ACCESSORIES

The following parts are not supplied with the 53SE1 but are useful for some installations.

1. Weatherproof boot for reset switch — ECA Part No. 33-414
2. Hoffman Enclosure — ECA Part No. 1-820
14 Gauge Steel Oiltight & NEMA IV 14 x 6¼ x 4¾
May be ordered direct from:

Hoffman Engineering Company
Division of Federal Cartridge Corporation
Anoka, Minnesota 55303

Their Part No. E-10PBX-BC

Any similar enclosure that will accommodate the 10" x 2¼" x 4" unit may be used.

3. Engraving Plate — ECA Part No. 3-1705

This is a blank engraving plate laminated black on white 1/16 thick. It matches the front plate of the 53SE1 and is mounted by the two 10-32 mounting screws of the 53SE1. The locknut for the reset switch must be removed to mount the plate and then replaced.

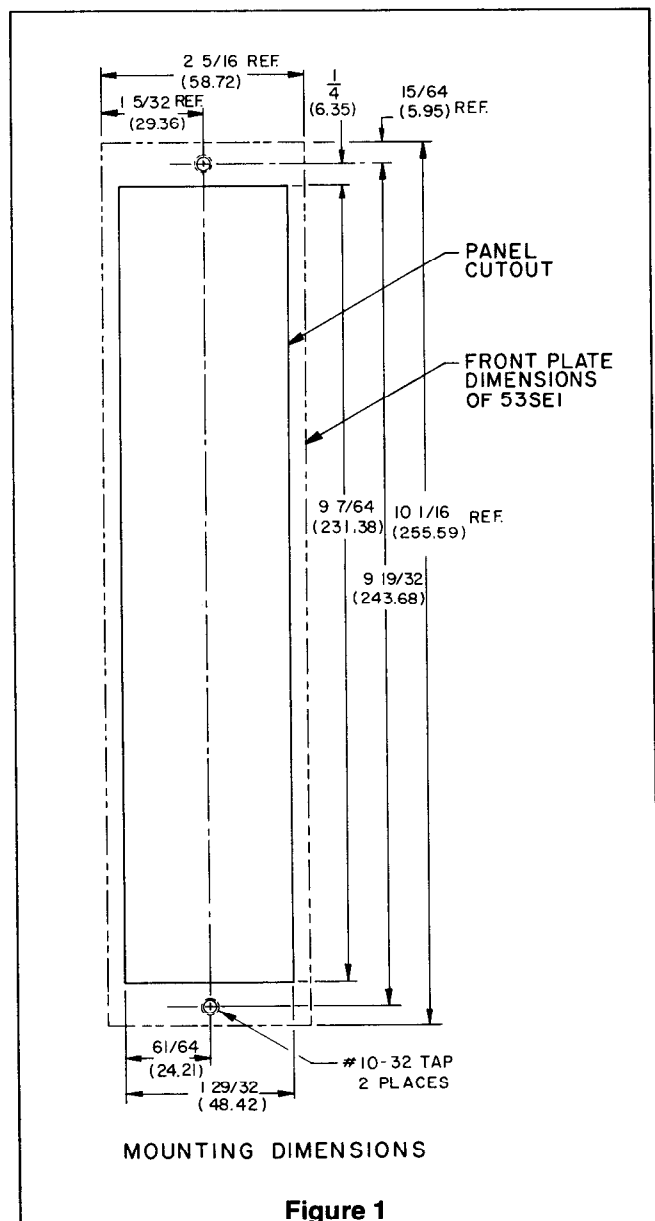

WIRING DIAGRAMS

TYPICAL WIRING ARRANGEMENT FOR AN INDUSTRIAL PROCESS

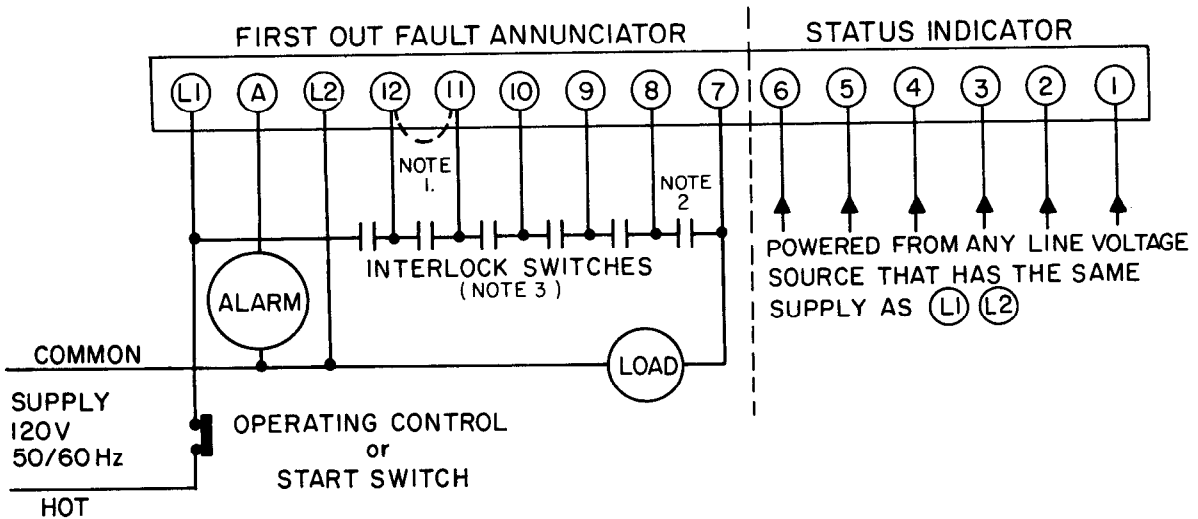

NOTES

1. JUMPER ANY UNUSED INTERLOCK CIRCUIT.
2. CONNECT THE LAST INTERLOCK TO CLOSE, TO TERMINAL 7.
3. THE INTERLOCKS NEED NOT BE CONNECTED IN A SERIES STRING. HOWEVER THEY MUST ALL BE CONNECTED IN A CIRCUIT THAT HAS THE SAME SUPPLY AS (L1) (L2)

Figure 2

TYPICAL WIRING ARRANGEMENT - FIREYE 'C' SERIES FLAME SAFEGUARD CONTROL WITH ECA 53SEI AND A PILOT IGNITED OIL/GAS BURNER

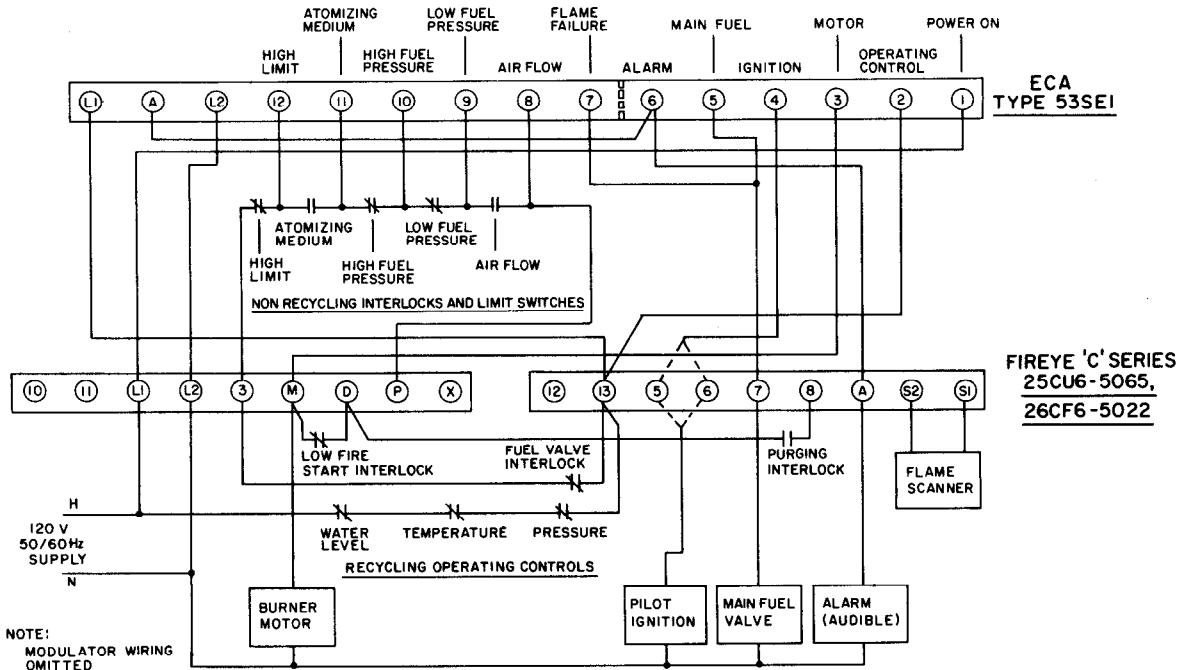

NOTE:
MODULATOR WIRING
OMITTED

Figure 3

WIRING DIAGRAM

Figure 4 shows a method of connecting two system indicators into a single system where it is desired to obtain first out information from more than six interlocks. Two system indicators will provide first out interlock information for up to twelve interlocks. In order to restrict the first out information to the indication of the first interlock to open, it is necessary to add relays A and B so that a first out indication on system A will disconnect system B and a first out indication on system B

will disconnect system indicator A.

The neon lamp indicators are omitted from Figure 4 for clarity but the combination of the two system indicators provides an indicating lamp capacity of twelve interlocks. These may be connected in any part of the system as long as the signalling voltage is limited to 120 volts and the supply voltage has a common conductor connected to terminal L2.

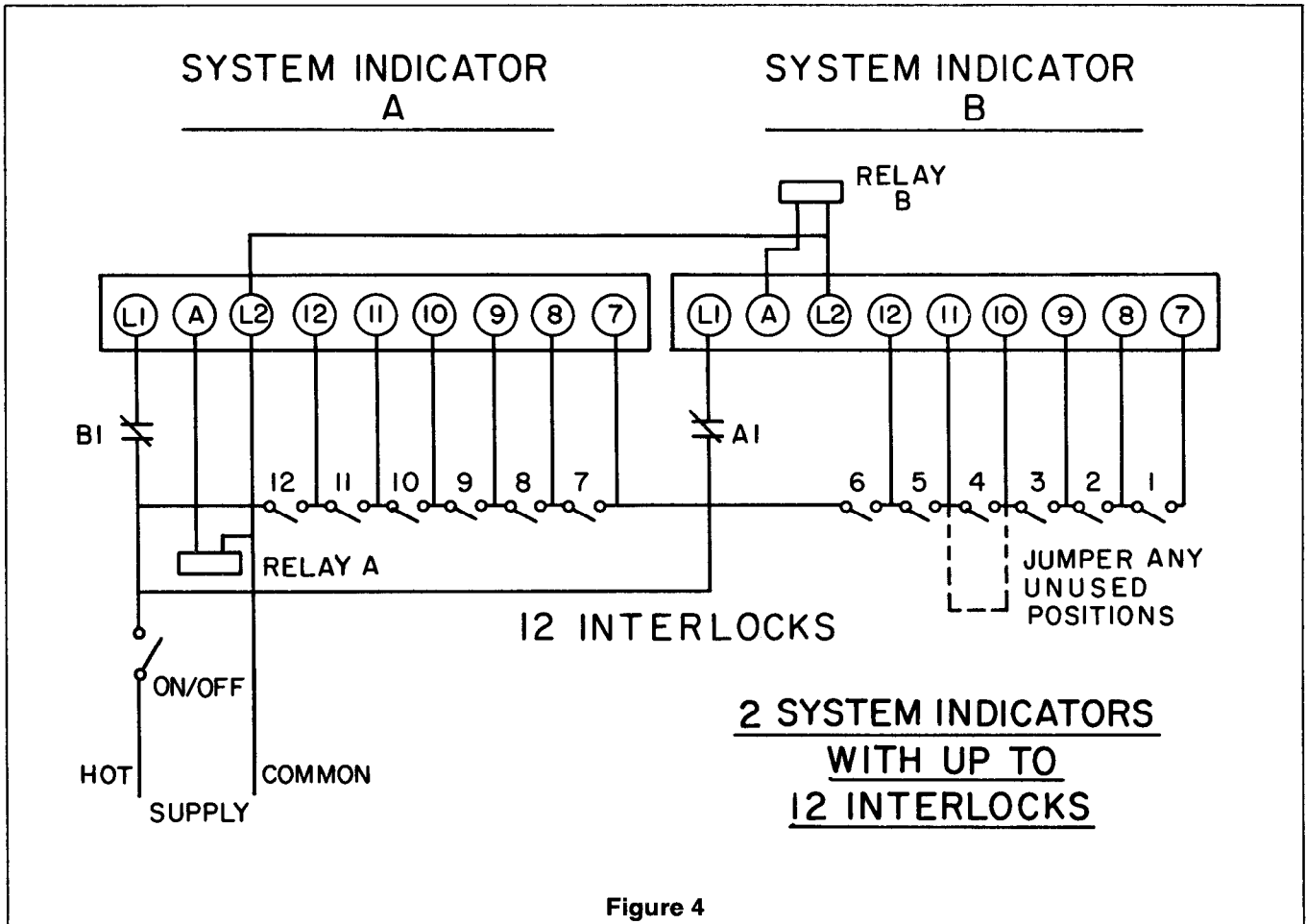

Figure 4

WARRANTIES AND PURCHASER'S EXCLUSIVE REMEDIES

We guarantee for one year from date of shipment to replace or, at our option, to repair any products or parts thereof (except lamps, electronic tubes and photocells) which are found defective in material or workmanship or which otherwise fail to conform to the contract description or to any warranty, express or implied.

We make no warranties which extend beyond the descrip-

tion of our product on the face of our sales orders.

The Purchaser's remedies with respect to any product or part sold by us shall be limited exclusively to the right to replacement or repair f.o.b. Cambridge, as above provided. In no event shall we be liable for consequential or special damages of any nature which may arise in connection with such product or part.



ELECTRONICS CORPORATION OF AMERICA

One Memorial Drive—Cambridge, Massachusetts 02142

Area Sales Offices: BOSTON • NEW YORK • PHILADELPHIA • ATLANTA • CLEVELAND • DETROIT • CHICAGO • HOUSTON • LOS ANGELES • SAN FRANCISCO

Subsidiaries: ELECTRONICS CORPORATION OF AMERICA • (CANADA) LTD., TORONTO • MONTREAL • VANCOUVER • (INTERNATIONAL) • (EUROPE) N.V. • (FRANCE) S.A. • (GREAT BRITAIN) LTD. • (NETHERLAND) N.V. • (DEUTSCHLAND) G.m.b.H. • (ITALIA) S.p.A.