



## **FIREYE C9701A Ultraviolet Flame Scanners**

---

### **DESCRIPTION**

The Fireeye C9701A Flame Scanner provides an effective means of flame monitoring in an application where a scanner can be mounted in a direct line of sight from the flame to be monitored.

The C9701A Ultraviolet Flame Scanner responds to ultraviolet (UV) radiation wavelengths between 1850 and 2650 angstroms, which are emitted by natural gas and light oil (No. 2) flames. If coal, heavy oil or other residual fuels are used, the C9707A All Fuel Scanner should be utilized.

The C9701A Flame Scanner incorporates an ultraviolet sensitive detector tube, electronic circuitry to generate and transmit an output signal, a quartz viewing window and a mechanical light blocking chopper, which is used to test detector tube status.

The scanner chassis is mounted in a weatherproof cast aluminum enclosure. The base casting and cover casting fit together and are secured with spring-loaded, half-turn fasteners. The base casting has a 1-inch NPT (National Pipe Thread) tapping for mounting onto a threaded sight pipe. The base also includes a 3/4-inch NPT tapping for connection of a purge air line.

---

### **FEATURES**

- Adjustable gain control within the scanner module.
- Electronic circuitry to process and transmit an output signal.
- A mechanical “light chopper” that blocks the UV tube from light at preset intervals, testing its status.
- Scanner electronic circuitry mounted in a weather-proof cast aluminum enclosure.
- For use with R9107A Controller, see bulletin 65-8046.
- For use with 25SU3-2100 Controller, see bulletin CU-34.

## OPERATION

The C9701A incorporates an ultraviolet sensor that detects radiation in the range from 1850 to 2650 angstroms; which is produced by burning gas and light (No. 2) oil.

### Sensitivity Adjustment

The scanner sensitivity potentiometer is used to adjust ultraviolet (UV) radiation signals to levels that are usable for the controller to process. The amount of UV radiation reaching the scanner can vary greatly with the distance, sighting, and size of the flame. As a result, the flame signal can also vary greatly. In order for the flame controller to properly process the flame signal, it must fall within certain parameters. The scanner sensitivity adjustment allows this, making the system as reliable with a small flame as with a large flame, regardless of distance and sighting.

### Scanner Testing (Self-Check)

Scanner testing is initiated by a test signal from the controller that causes a mechanical light blocking chopper in the scanner to block the flame radiation from reaching the sensor for one out of every 10 seconds. The system must respond to this absence of a flame signal or the controller will indicate a fault condition.

## SPECIFICATIONS

**ELECTRICAL:** Power for the flame scanner is provided by the supervising flame controller. Cables with a military connector are available in standard lengths. See "Accessories" section.

**MECHANICAL:** 1 inch NPT to sight pipe, 3/4 inch NPT purge air.

**OPERATING TEMPERATURE RANGE:** -4°F to +160°F (-20°C to +71°C)

**SHIPPING WEIGHT:** 7 pounds (3.18 kilograms).

**RESPONSE RANGE:** 1850 to 2650 angstroms.

**DIMENSIONS:** See Figure 1.

**PURGE AIR RECOMMENDED:** 600 standard cubic feet per hour at 13 inches water column over furnace pressure.

**FIGURE 1. C9701A ULTRA VIOLET FLAME SCANNER DIMENSIONS**

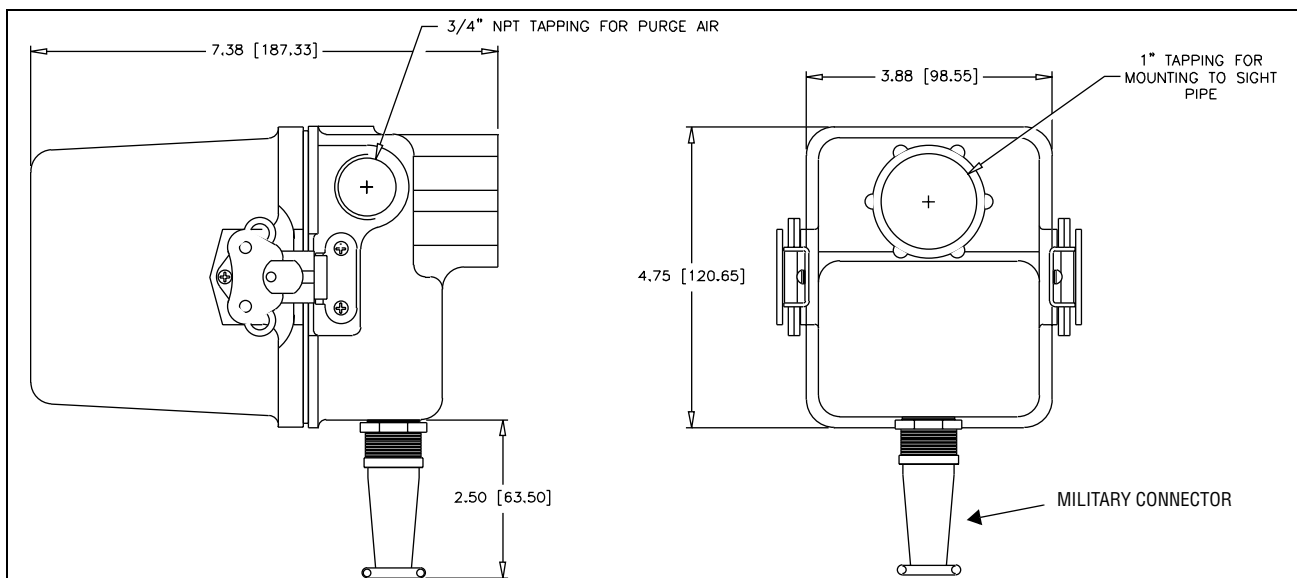

## INSTALLATION

### Flame Scanner Mounting

1. Choose a sighting location where the scanner will have an unobstructed view of the flame under all firing conditions. Greatest ultraviolet radiation is produced near the base of the flame in the area immediately ahead of the burner.  
A scanner monitoring a pilot flame and a main flame must be positioned so that it can sight both flames.  
In multiple burner furnaces, choose a sighting angle with the best possible view of the flame of interest and the poorest view of other flames in the furnace. The sight pipe should be inclined slightly downward, so that unburned particles or condensed moisture will not fall or drain onto the scanner.
2. Prepare a hole in the burner front or windbox wall to clear the sight pipe at the angle of approach selected. Select a length of 1 inch standard pipe (with NPT thread on one end) no longer than is necessary to place the scanner housing in an unobstructed and accessible area. If a sight pipe longer than 12 to 18 inches is required, the sight pipe should be of larger diameter (2 inch pipe, for example) with the reduction to 1 inch occurring as close to the scanner as practical, so the field of view will not be reduced to a narrow angle.
3. Thread scanner base assembly onto the sight pipe until tight, making certain that in the final position the wiring connector points down.
4. Tack weld the sight pipe to the boiler front plate at the selected location and angle of sight. Project the pipe through the hole in the firewall surface.
5. In many instances it will be convenient to use a swivel mount (model number 60-1664-3) that is threaded onto the sight pipe. This arrangement allows angular adjustment within a cone of approximately 20 degrees.
6. Terminate the assembly at a junction box and connect the leadwires to conductors extending to the flame control module. Table 1 identifies the color of the PVC cable wiring scheme. The hypalon cable has either the color code shown in Table 1 or Table 2. Check the wire colors of the cable and match them with one of the two tables. The standard military connector/cable is an 18 gauge - 5 conductor cable with a 5 pin plug assembly used to connect the scanner to the controller. Fireye also offers a kit to facilitate this connection. Table 1 shows the pin connections.
7. The introduction of cooling and/or purging air is required. A positive flow of air down the sight pipe can eliminate the necessity for frequent window cleaning and prevent transmission losses caused by products of combustion in the sight path. The purge air source must be oil free and dry and it should provide 600 standard cubic feet per hour at 13 inches water column over furnace pressure. Unless the purge line includes a flexible connecting portion, it cannot be attached until the permanent scanner position has been determined.

**Table 1: PVC and Current Hypalon Cable Color Codes - Pin Connections**

FUNCTION	CONNECTOR DATA	
	WIRE COLOR	PIN NO.
SIGNAL OUTPUT	BLUE	B
+28 VDC FROM CONTROLLER	ORANGE	A
FROM CHOPPER DRIVE	YELLOW	C
GROUND	BLACK	E
UNUSED	RED	D

**Table 2: Early Hypalon Cable Color Code**

PIN	CABLE COLOR	FUNCTION
A	ORANGE	+28 VDC
B	GREEN	SIGNAL
C	WHITE	CHOPPER
D	RED	UNUSED
E	BLACK	GROUND

**Sighting Adjustment**

An inadequate signal may be the result of improper sighting, poor combustion or an improper scanner for the fuel being burned. If the sight pipe was only tack welded, as instructed, or if it is on a swivel mount, vary the angle to achieve the highest voltage signal reading.

If the scanner is used to monitor both pilot and main flames, adequate signal from each flame should be verified with the other flame off. If a good signal can be acquired from both flames only at two different angles, either the sight pipe should be relocated to a more appropriate area or the use of two scanners should be considered.

In multiple burner furnaces where individual flame discrimination is required, it is possible that a strong signal will be received from an interfering flame as well as from the flame of interest. The best way to correct this condition is to restrict the size of the viewing orifice on the scanner so that the signal intensity from both flames is reduced. Assuming that the monitored flame, which has an optimized sighting angle, will provide a greater signal than an adjacent flame, a reduction of signal strength (by restricting the viewing orifice) will permit the differences in signal level from the two flames to be recognized.

**IMPORTANT: The electric spark used to ignite a pilot flame is an emitter of ultraviolet and infrared radiation. To ensure that the sighting arrangement does not permit the detection of direct or reflected spark energy, a flame signal reading of no more than 1 volt should exist with fuel sources shut off and spark energized. Re-align the scanner or optically shield the igniter, if necessary, to avoid spark detection. As an additional precaution, it is a common and recommended practice to de-energize the ignition transformer simultaneously with the energizing of main fuel valves.**

**IMPORTANT: A scanner should not respond to a pilot flame that is too small to reliably ignite the main burner. This can be checked by reducing the pilot flame size to the smallest that can be detected (sensitivity set to maximum) and then determining that such reduced flame will readily ignite the main burner fuel.**



**CAUTION: If ignition of main flame does not occur at once, or is slower than usual, shut off fuel immediately, re-adjust the scanner to sight further out, and repeat the test.**

If the pilot flame signal is relatively strong, the viewing orifice should be restricted to inhibit detection of a pilot flame. The sensitivity control should not be used to attenuate the signal in this instance unless some means is provided to guard against the setting being changed.

**IMPORTANT: When satisfactory sighting has been achieved, the sight pipe should be permanently welded in place to maintain the selected position. If a swivel mount is used, tack weld it to prevent further movement.**

With the sight pipe in a fixed position, a permanent purge air line connection can be made to the scanner base.

## FINAL CALIBRATION

Scanner gain is most easily adjusted at the controller using the "Gain Adjustment" procedure in the R9107A controller bulletin 65-8046.

*NOTE:* The scanner sensitivity potentiometer located within the scanner housing (see Figure 2) should be set at 100 percent when initially performing this procedure.

If the required signal readings cannot be obtained using the scanner gain adjustment on the controller, the C9701A scanner sensitivity potentiometer can also be adjusted to obtain the required readings. The potentiometer is labeled with a 0 to 100 scale (indicating percent) and an arrow that indicates the present setting. It is a single turn potentiometer with two end stops. Turning the potentiometer counterclockwise to the "0" setting reduces the scanner sensitivity. Turning the potentiometer clockwise to the "100" sets the scanner at maximum sensitivity.

To adjust the C9701A sensitivity, remove the rear cover of the scanner housing and locate the sensitivity potentiometer shown in Figure 2. Use a thin standard blade screwdriver to adjust for the required response as described in the "Gain Adjustment" section of the controller manual.

**FIGURE 2. LOCATION OF POTENTIOMETER**

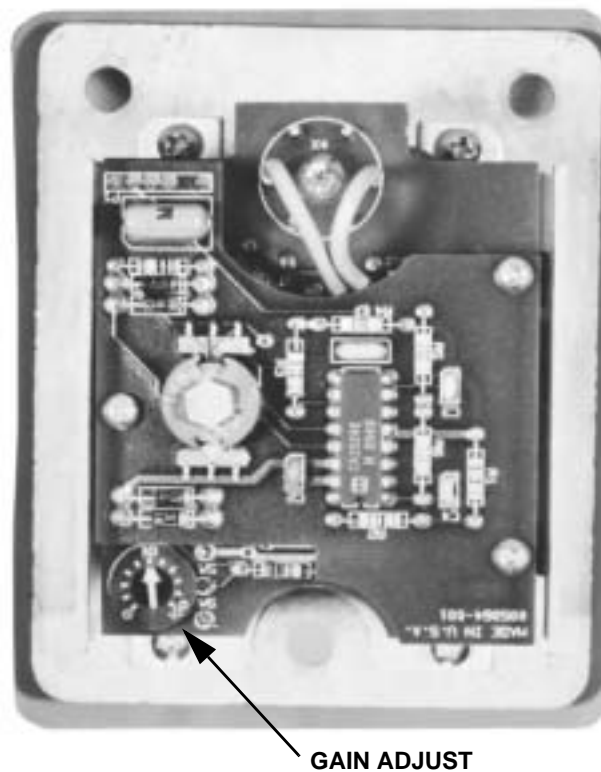



## HOW TO ORDER SCANNER

*When ordering specify:*

PART NUMBER	DESCRIPTION
C9701A 1012	UV Scanner, standard electronics, with front mounting base
C9701A 1023	UV Scanner, conformally coated electronics, with front mounting base

## REPLACEMENT PARTS

PART NUMBER	DESCRIPTION
DE601-104G	Scanner front mounting base, military connector for C9701A1012 and C9701A1023 scanners.
DE701-107A	UV Scanner Electronics Assembly (without base) for C9701A1012, standard model.
DE701-107C	UV Scanner Electronics Assembly (without base) for C9701A1023, conformally coated model.
DE4606-001	Sight Restrictor Kit (Consists of three sight restricters and one retaining ring). See bulletin 65-8052 for more information.
101537-001	Retaining ring for sight restricter.

## ACCESSORIES

PART NUMBER	DESCRIPTION
DE601-006	5 pin military connector kit with cable clamp. See bulletin 65-8027 for more information.
DE601-006B	5 pin military connector kit with flexible conduit adapter. See bulletin 65-8027 for more information.
500287-001	Scanner cable, 18AWG, 600V, sold by the foot. Use with DE601-006, -006B connector kits.
60-1664-3	Swivel mounting assembly.

### Prefabricated Scanner Cables

When ordering scanner cables, specify the part number and the length required.

PART NUMBER	DESCRIPTION
DE4360-XXX	Cable/Connector with cable-clamp assembly. Available lengths: 10, 20, 40, 60, 80 and 100 feet.
DE4599-XXX	Cable/Connector with flexible conduit adapter. Available lengths: 10, 20, 40, 60, 80, 100, 120, 140, 160, 180 and 200 feet.
000710-023	Test cable, 10 ft. (allows scanner electronics assembly to be removed from the DE601-104G base for testing).





---

## NOTICE

When Fireeye products are combined with equipment manufactured by others and/or integrated into systems designed or manufactured by others, the Fireeye warranty, as stated in its General Terms and Conditions of Sale, pertains only to the Fireeye products and not to any other equipment or to the combined system or its overall performance.

---

## WARRANTIES

FIREEYE guarantees for *one year from the date of installation or 18 months from date of manufacture* of its products to replace, or, at its option, to repair any product or part thereof (except lamps, electronic tubes and photocells) which is found defective in material or workmanship or which otherwise fails to conform to the description of the product on the face of its sales order. **THE FOREGOING IS IN LIEU OF ALL OTHER WARRANTIES AND FIREEYE MAKES NO WARRANTY OF MERCHANTABILITY OR ANY OTHER WARRANTY, EXPRESS OR IMPLIED.** Except as specifically stated in these general terms and conditions of sale, remedies with respect to any product or part number manufactured or sold by Fireeye shall be limited exclusively to the right to replacement or repair as above provided. In no event shall Fireeye be liable for consequential or special damages of any nature that may arise in connection with such product or part.



FIREEYE™  
3 Manchester Road  
Derry, New Hampshire 03038  
[www.fireeye.com](http://www.fireeye.com)

65-8058  
JULY 18, 2005  
Supersedes June 1993

