



NXCESO2-1001  
OCTOBER 20, 2011

# NXCESO2 OXYGEN PROBE

**For Use with PPC4000  
Parallel Positioning Control**



## DESCRIPTION

The Fireeye NXCESO2 oxygen probe is designed to be used with the PPC4000 and provides continuous oxygen concentration readings allowing the PPC4000 to trim the air or fuel servo to obtain optimum combustion efficiency. The NXCESO2 offers fast, accurate response and excellent reliability when mounted in accordance with the guidelines shown.

Along with the oxygen (O<sub>2</sub>) concentration, the NXCESO2 provides the stack temperature utilizing a type K thermocouple up to 800°F (426°C). On board electronics measure the ambient temperature and control an integrated cooling fan that is used to maintain the internal temperature between 45°C and 70°C.

The wide band lambda sensor LSU is a planar ZrO<sub>2</sub> (zirconium dioxide) dual cell limiting current sensor with an integrated heater and pump control. The wide band oxygen sensor responds to changes in the air/fuel mixture in less than 100 milliseconds. The oxygen sensor cartridge is designed to allow for easy replacement without the need to remove the probe from the stack, minimizing down time.

The NXCESO2 requires 2 power leads (24 vdc) and a twisted shielded pair for modbus-RTU communications. Fireeye cable part number 59-565 is suitable for all installations. When connected to the PPC4000, the PPC4000 automatically detects the NXCESO2 through the modbus-RTU communications. The USER INFO screen on the PPC4000 will display the current O<sub>2</sub> level, stack temperature and NXCESO2 status register. To be used as a trim system the NXCESO2 must be commissioned with the PPC4000. The NXCESO2 can be added to a previously commissioned system without the need for re-commissioning the servos. That is, the previously commissioned profile setpoints remain valid. Refer to bulletin PPC-4001 for connection, setup, commissioning and operation information.

The NXCESO2 is available to be used independently. All data pertaining to oxygen concentration, stack temperature, ambient temperature and operational status is available through modbus-RTU communications. Local codes having jurisdiction and authority over the use of such instruments should be consulted.

## ORDERING INFORMATION

NXCES02-8	O2 probe assembly – 8.5 inch (216 mm) insertion depth.
NXCES02-16	O2 probe assembly – 16 inch (407 mm) insertion depth.
NXCES02-30	O2 probe assembly – 30 inch (609 mm) insertion depth.
59-565	Cable, contains two power leads, twisted pair and drain wire.
NXCES02P42	Replacement oxygen sensor cartridge for NXCES02P42 engineering code 01 and above
NXCES02P42-1	Replacement oxygen sensor cartridge for NXCES02P42 engineering code 00 only
35-381-2	Kit, mounting flange, carbon steel. Includes mounting flange, gasket and mounting screws
129-189	Mounting flange cover. Used when flange is mounted in lieu of O2 probe.

## SPECIFICATIONS

<b>Supply Voltage:</b>	24VDC
<b>Power Consumption:</b>	12VA
<b>Humidity:</b>	85% RH maximum non-condensing
<b>Temperature Rating:</b>	32°F to 140°F (0°C to +60°C)
<b>Internal Fan Control:</b>	On @70°C, Off @45°C
<b>Maximum stack temp:</b>	850°C (1562°F)
<b>Protection Category:</b>	NEMA 1 (IP01)
<b>Unit Dimension:</b>	see Figure 2 (pg 4)
<b>Shipping Weight:</b>	
	NXCES02-8 : 8.1lbs (3.67 kg)
	NXCES02-16: 9.2 lbs (4.17kg)
	NXCES02-30: 11.4 lbs (5.17kg)

### Wiring Connections

**FIGURE 1. NXCES02 INTERNAL PC BOARD**

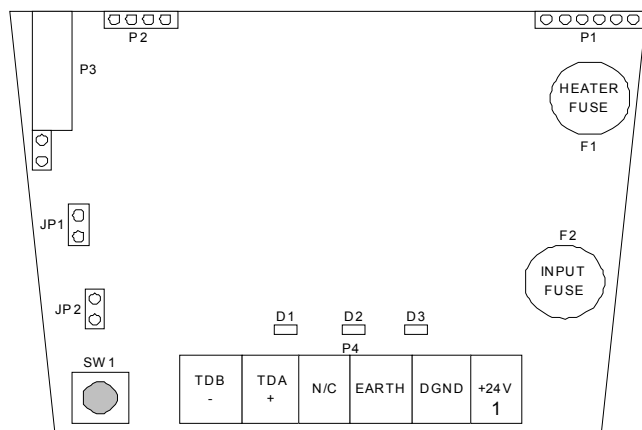

Wiring Terminal Block  
see Figure 4

NXCES02	DESCRIPTION	59-565	PPC4000
6	TDB (-)	MODBUS -	BROWN P12-12
5	TDB (+)	MODBUS +	ORANGE P12-11
4	N/C	-	-
3	EARTH		DRAIN EARTH
2	DGND	RETURN	BLACK P2-5
1	+24V	POWER	RED P2-1

Remove power when servicing

SW1	Provides fault reset and forced calibration	
JP1	Baud rate selector. In is 57600 (PPC4000), Out is 19200	
JP2	RS485 termination resistor	
F1	Heater Fuse	23-231
F2	Input Fuse	4A, 125V Type LFMX

COMPONENT	FUNCTION
D1	Fault LED
D2	Activity LED
D3	CALIBRATION LED
P1	OXYGEN Sensor connector
P3	Thermocouple connector (K-type)
P4	Power supply and RS-485 communication port
F1	Heater fuse. Rated for 4A, 125 vac; Type LFMX, P/N 23-231
F2	+24V input fuse. Rated for 4A, 125 vac; Type LFMX, P/N 23-231
SW1	Reset switch. Press and release to clear fault. Press and hold for 10secs to reset system.
JP1	Baud-rate selector. With jumper in place for 57600. With jumper cut for 19200.
JP2	RS-485 Termination jumper. When installed, RS-485 port is terminated with 120 Ohm resistor

## NXCES02 Dimensional Information

FIGURE 2.

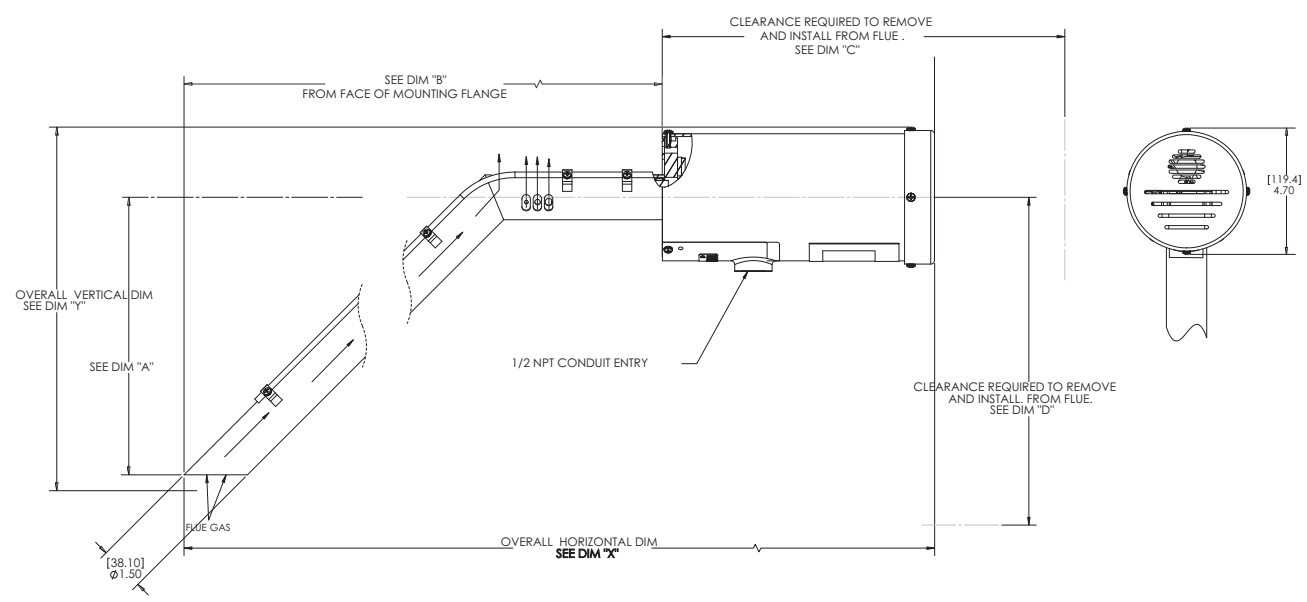

MODEL NUMBER	DIM "A"	DIM "B"	DIM "C"	DIM "D"	DIM "X"	DIM "Y"
NXCES02-8	( 44) 1.69	(216) 8.50	(426) 16.75	(324) 12.75	(445) 17.50	(121) 4.75
NXCES02-16	(236) 9.22	(407) 16.03	(692) 27.25	(324) 12.75	(637) 25.06	(295) 11.63
NXCES02-30	(586) 23.01	(757) 29.82	(1187) 46.75	(324) 12.75	(648) 25.50	(987) 38.87

## Recommended Oxygen Probe Mounting Positions

The O<sub>2</sub> probe mounts in the stack using Fireye mounting flange kit 35-381-2. Refer to document 133-750 for installation details.

The probe must be mounted in a manner that ensures that the flue gases pass into the gas tube at its open end and out of the tube at the flange end. Furthermore, if possible, the flange should be vertical with the gas tube angled downwards to ensure that particulates do not build up within the sample tube. Probe mounting with the flange horizontal is acceptable. Inverted probe mounting is not acceptable.

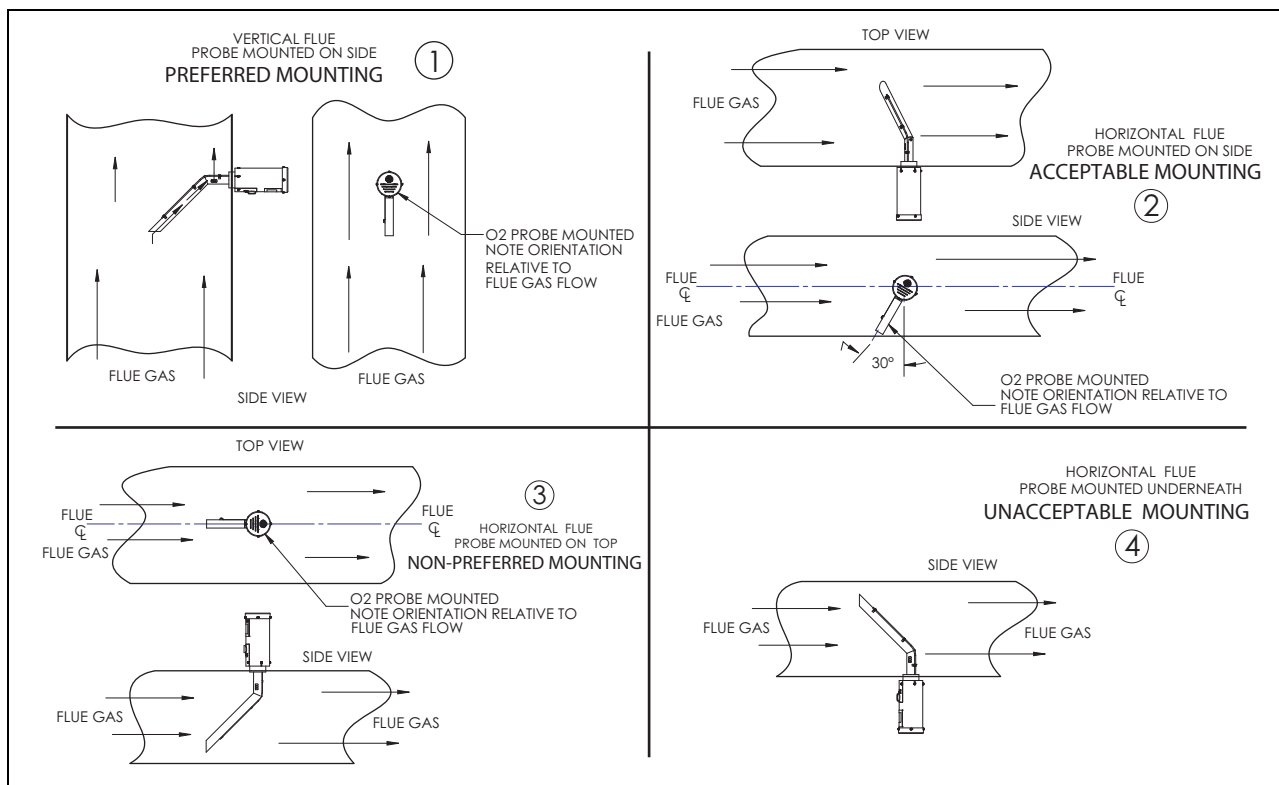

## OPERATION

The NXCESO<sub>2</sub> is powered with 24 vdc supplied from the PPC4000. On systems that contain more than 4 servos, it is recommended an external 24vdc supply be used for the O<sub>2</sub> probe power. The NXCESO<sub>2</sub> contains 3 LED's located on its circuit board. These LED's indicate normal activity (blinking), fault, and calibration completed. The calibration completed LED will remain illuminated until the next power cycle.

The NXCESO<sub>2</sub> reads the oxygen sensor 3 times per second and the stack temperature and ambient temperature 1 time every second. This means for each 1 second interval there are 3 oxygen concentration readings, 1 stack temperature reading and 1 ambient temperature reading. The remaining time is used to service modbus-RTU requests, monitor the internal power supply voltages, monitor the integrity of the stack temperature, ambient temperature and oxygen sensor devices, execute internal diagnostic tests on the CPU including ram tests, I/O tests, and program memory CRC tests, and to monitor the internal temperature that will force the internal fan on and off as necessary. Any errors are reported in the status register and transmitted via modbus to the host.

The wideband flue gas oxygen sensor consists of two parts: a Nernst reference cell and an oxygen pump cell, co-existing in a package that contains a reference chamber and heater element (used to regulate the temperature of the Nernst/pump).

The wideband air/fuel ratio sensor combines an oxygen-sensing "Nernst" cell from the narrow band sensor with an "oxygen pump" to create a device that gives a wide range response to various air/fuel ratios. The Nernst cell senses flue gas oxygen in the same manner as a conventional narrow band O<sub>2</sub> sensor. If there is a difference in oxygen levels across the ZrO<sub>2</sub> sensor element, current flows from one side to the other and produces a voltage.

**FIGURE 3. Wideband O<sub>2</sub> sensor - Internal structure**

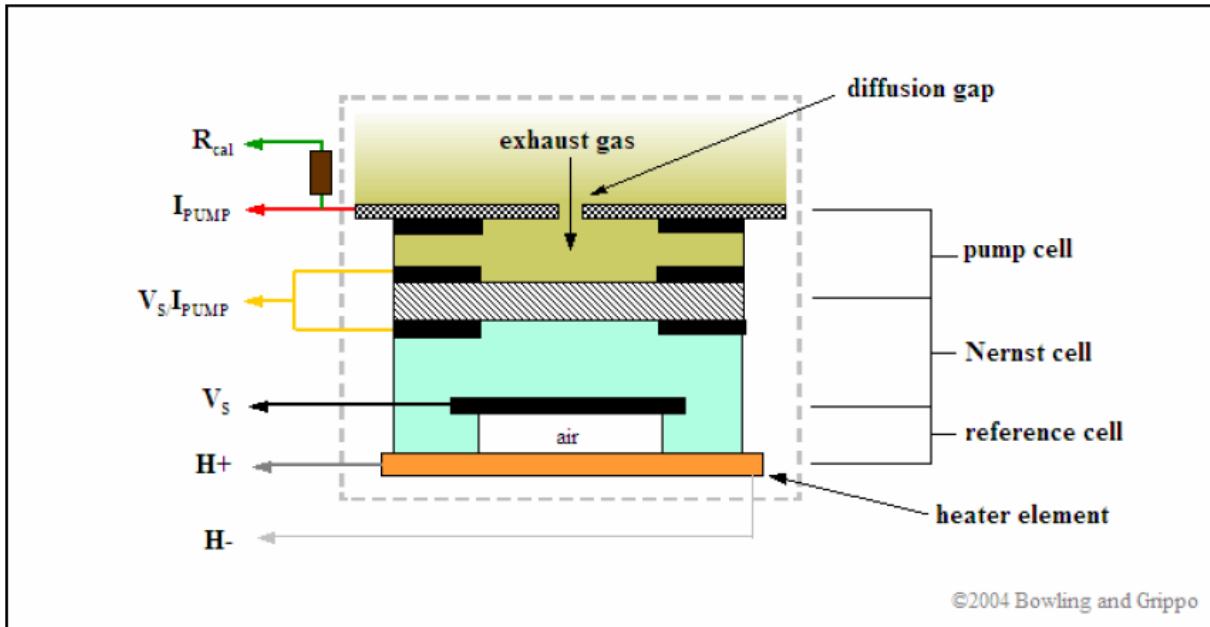

The Nernst cell is an electrochemical cell consisting of a solid electrolyte conductive only to oxygen ions. Attached to this electrolyte are two platinum electrodes. One electrode is exposed to atmosphere and the other is exposed to a reference chamber. There is a heater maintaining the Nernst cell at an elevated temperature, causing a temperature gradient to exist which generates an offset voltage.

The Nernst cell and oxygen pump cell are wired together in such a way that it takes a certain amount of current to maintain a balanced oxygen level in the diffusion gap. Measuring this current flow allows the precision wideband controller to determine the exact air/fuel ratio.

The pump cell can either consume oxygen or consume hydrocarbon fuel in the pump cell cavity, depending on the direction of the pump cell current flow (**I<sub>pump</sub>**).

In normal sensor operation, flue gas passes through the diffusion gap into the pump cell. That flue gas is often either rich or lean of stoichiometric. Either condition is sensed by the reference cell which produces a voltage (**V<sub>s</sub>**) above or below the **V<sub>ref</sub>** signal, just like a narrow band sensor).

Combustion is rarely perfect though. Even with the correct air/fuel ratio (AFR), combustion can still be incomplete, and CO, H<sub>2</sub>, NO<sub>x</sub>, and hydrocarbons (HC) can form.

When the air/fuel mixture is rich, the reference cell produces a high **V<sub>s</sub>** voltage (above 0.450 volts). The precision wideband controller reacts to produce a pump current (**I<sub>pump</sub>**) in one direction to consume the free fuel. The pump cell requires a "negative" current that goes from zero to about 2.0 milliamps when the air/fuel ratio is near 11:1.

When the air/fuel mixture is lean, the reference cell produces a low **V<sub>s</sub>** (lower than 0.450 volts). The precision wideband controller sends the pump current in the opposite direction to consume free oxygen. The pump cell requires a "positive" current that goes from zero up to 1.5 milliamps as the mixture becomes "free air".

When the air/fuel mixture is at stoichiometric, the pump cell requires no output current. Since the free oxygen or free fuel has been neutralized by the pump current, the **V<sub>s</sub>** feedback signal goes to about 0.450 volts (the same as the **V<sub>ref</sub>** value).

To sense a wide range of air/fuel ratios, the oxygen pump uses a heated cathode and anode to pull some oxygen from the flue into a "diffusion" gap between the two components. The pump is driven by two PWM or processor ports in opposite polarity (using either a H-bridge setup or direct processor port drive), and the precision wideband controller measures the time when the reference cell passes through 0.45 volts. It can then adjust the PWM timing to bracket this 0.45 volt stoichiometric flipping point.

Like a conventional narrow band sensor, the precision wideband controller circuit produces a low-voltage signal when the air/fuel ratio goes lean, and a high-voltage signal when the mixture is rich. But instead of switching abruptly at stoichiometric, it produces a proportional change in the voltage. It increases or decreases in proportion to the relative richness or leanness of the air/fuel ratio. With a stoichiometric air/fuel ratio, the wide-band O<sub>2</sub> sensor will produce a steady 0.450 volts. If the mixture goes a little richer or a little leaner, the sensor's output voltage will only change a small amount instead of rising or dropping dramatically.

The result is a sensor element that can precisely measure air/fuel ratios (AFR) from very rich (10:1) to extremely lean (free air).

**FIGURE 4. O<sub>2</sub> Probe Key Component Locations**

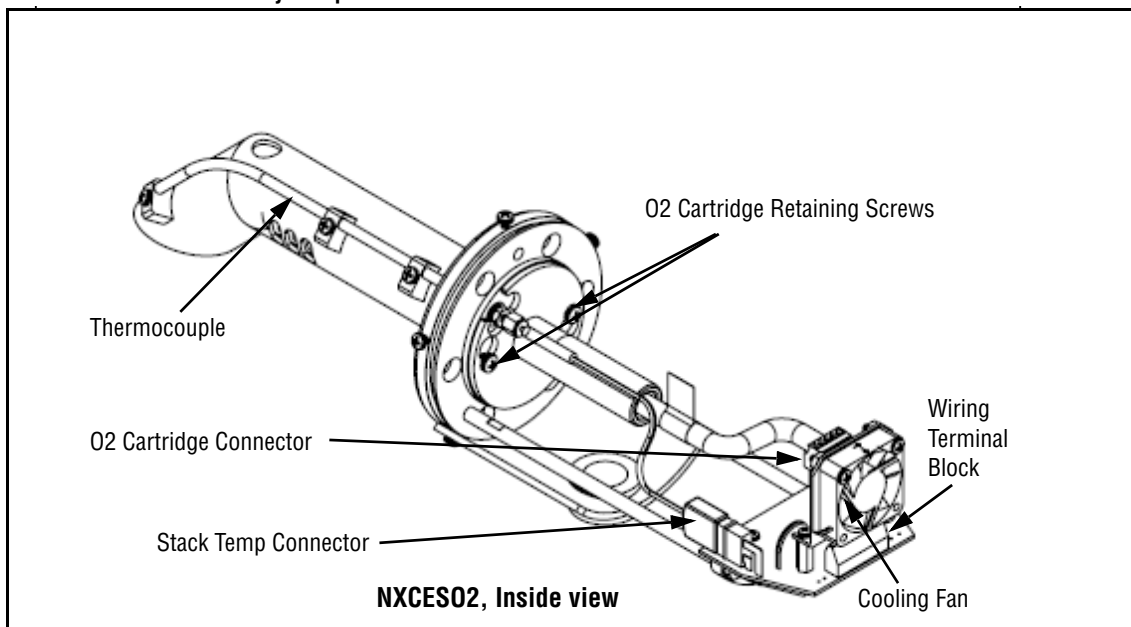

**Wiring:**

Access to the wiring terminal block (see figure 4) requires the internal fan to be removed. Referring to figure 5, loosen the fan retaining screws(2) to remove the fan. Referring to figure 1, connect external wires to terminal block. Re-attach fan and tighten fan retaining screws.

**FIGURE 5. Flue Gas Flow through Probe**

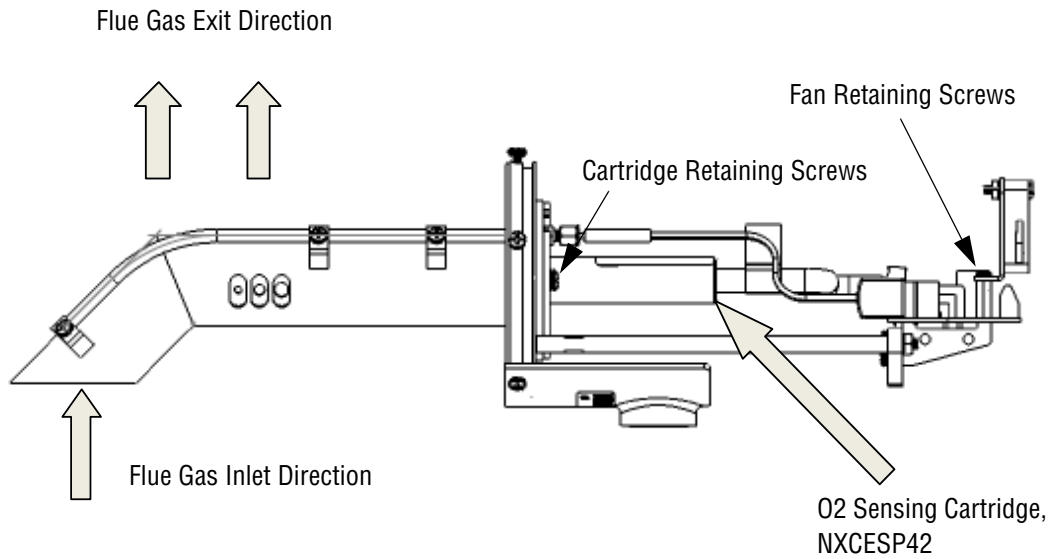

**Replacement O2 Cartridge**

NOTE: Fireye has made various improvements to the NXCESO2 oxygen probe. Among the improvements is the connector on the end of the replacement cartridge and the mating shell located on the printed circuit board. The engineering code located on the cartridge unit label, shown below, can be used to determine which replacement cartridge is required. NXCESO2P42-1 can be used only with code 00 cartridges. NXCESO2P42 replacement cartridges can be used to replace all other units with engineering code 01 and higher

**FIGURE 6. NXCESO2P42 Replacement Cartridges**

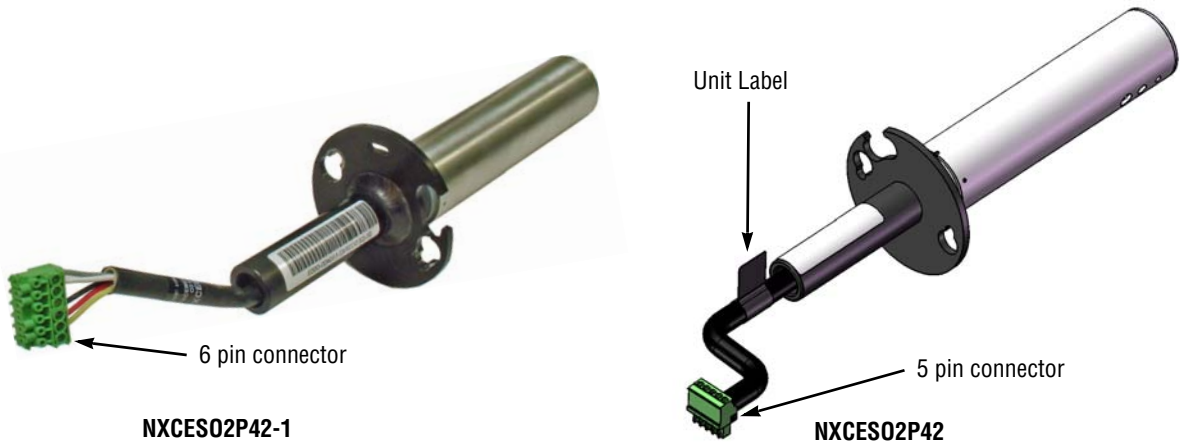

To replace the cartridge the following steps are recommended:

1. Remove power from the O2 probe and allow O2 sensor heat to cool.
2. Remove outside cover from O2 probe and set aside.
  - a. Loosen but do not remove the thumb screws and slide cover to rear and off. [At this time, if necessary, power to the probe can be disconnected at the terminal strip, pin 1]. The O2 probe should resemble the following:



3. Locate the connector end of the O2 cartridge and remove from shell located on O2 printed circuit board.
4. Unplug fan connector located on O2 printed circuit board.
5. Loosen and remove fan retaining screws (2) to remove fan and set aside.
6. Loosen but do not remove O2 cartridge retaining screws (2).
7. Rotate O2 cartridge counter-clockwise and withdraw from O2 probe flue pipe..
8. Insert replacement cartridge into flue pipe passed retaining screws and rotate clockwise to seat properly.
9. Tighten screws to secure cartridge in place.
10. Attach 5 pin connector on replacement cartridge to O2 printed circuit board.
11. Re-install cooling fan to mounting standoffs and secure with 2 screws.
12. Plug in fan connector to O2 printed circuit board.
13. Install O2 probe cover and secure with thumb screws.
14. Apply power to system or O2 probe.

### **Operator Push Button, SW1**

Referring back to Figure 1, the Operator Push Button, SW1 provides the installer\technician with the ability to reset the Oxygen Probe, perform an Oxygen Calibration, or clear the Fault LED, D1. The Activity LED, D2, is used as feedback to indicate to the installer\technician the status of the SW1 timing for the desired function.

### **Manual Reset**

If the Operator Push Button, SW1, is pressed after the Oxygen Probe has completed the power on or reset cycle (Oxygen Probe is in normal operation and Activity LED, D2, is blinking) then the Activity LED will begin cycling on and off in half second intervals for five seconds or until the Operator Push Button is released. If SW1 is held depressed through the five second interval, then the Activity LED will turn on (not blink) indicating to the user that a release of SW1 will initiate an Oxygen Probe Reset.

### **Fault LED Clear**

If the Oxygen Probe is in normal operation with the Activity LED, D2, blinking, a press and release of the Operator Push Button, SW1, before the five second interval has completed then the Fault LED, D1, will be cleared.

### **Manual Calibration**

With the NXCESO2 probe connected to the PPC4000, it is strongly recommended that calibration be performed through the NXD410 User Interface.

Manual Calibration should only be performed while there is clean air (no stack gases) flowing through the Oxygen Probe sensor. If the Operator Push Button is pressed during a power cycle or after a Manual Reset, then the Activity LED will begin cycling on and off in half second intervals for five seconds or until the Operator Push Button is released. If SW1 is held through the five second interval, then the Activity LED will turn on steady indicating to the user that a release of the Operator Push Button will initiate an Oxygen Calibration.

Care must be taken that if the Manual Calibration is performed after a Manual Reset, then immediately after releasing the button to start the reset, the button has to be pressed again before the reset process has finished. This has to be within a quarter second from button release to button press. The rest of the procedure must be followed as described above.

## Modbus memory map

The probe data is accessed using the modbus-RTU "Holding Register Read" request function (03). A single value can be read by performing a modbus holding register read request on only one of the registers by using the register address and a register count of one. The values of a series of adjacent registers can be accessed by using the address of the desired starting register and a count of the number of subsequent registers to read.

The modbus address of the O<sub>2</sub> probe is fixed at 11 (0xB).

The baud rate with JP1 in is 57600 baud.

The baud rate with JP1 cut is 19200 baud.

Register Number		Register Description
Holding register	Message address (Hex)	
40001	(0x00)	Probe Status
40002	(0x01)	Stack Temperature
40003	(0x02)	Ambient Temperature
40004	(0x03)	Extended O <sub>2</sub> Reading
40005	(0x04)	CO Expansion[0]
40006	(0x05)	CO Expansion[1]
40007	(0x06)	CO Expansion[2]
40008	(0x07)	CO Expansion[3]
40009	(0x08)	CO Expansion[4]
40010	(0x09)	CO Expansion[5]
40011	(0x0A)	Probe Firmware Rev
40012	(0x0B)	Probe ROM CRC
40013	(0x0C)	Stack Temperature Maximum Limit Configuration
40014	(0x0D)	Ambient Temperature Upper Limit Configuration
40015	(0x0E)	Ambient Temperature Lower Limit Configuration
40016	(0x0F)	Last Fault History Type
40017	(0x10)	Last Fault History Data
40018	(0x11)	2 <sup>nd</sup> to Last Fault History Type
40019	(0x12)	2 <sup>nd</sup> to Last Fault History Data
40020	(0x13)	3 <sup>rd</sup> to Last Fault History Type
40021	(0x14)	3 <sup>rd</sup> to Last Fault History Data
40022	(0x15)	4 <sup>th</sup> to Last Fault History Type
40023	(0x16)	4 <sup>th</sup> to Last Fault History Data
40024	(0x17)	5 <sup>th</sup> to Last Fault History Type
40025	(0x18)	5 <sup>th</sup> to Last Fault History Data
40026	(0x19)	6 <sup>th</sup> to Last Fault History Type
40027	(0x1A)	6 <sup>th</sup> to Last Fault History Data
40028	(0x1B)	7 <sup>th</sup> to Last Fault History Type
40029	(0x1C)	7 <sup>th</sup> to Last Fault History Data
40030	(0x1D)	8 <sup>th</sup> to Last Fault History Type
40031	(0x1E)	8 <sup>th</sup> to Last Fault History Data
40032	(0x1F)	9 <sup>th</sup> to Last Fault History Type
40033	(0x20)	9 <sup>th</sup> to Last Fault History Data
40034	(0x21)	10 <sup>th</sup> to Last Fault History Type
40035	(0x22)	10 <sup>th</sup> to Last Fault History Data
40036	(0x23)	Lambda (Disabled – when enabled value is supplied when Lambda < 8.512)
40037	(0x24)	Standard O <sub>2</sub> (Disabled - when enabled value is supplied when Lambda ≥ 8.512)
40038	(0x25)	Battery Voltage (Disabled)



## Probe Status Register

When reading the status register, the values are representative of a compound value and have the following bit definitions...

### Status Register Bit Positions

15	14	13	12	11	10	9	8	7	6	5	4	3	2	1	0
Stack		Ambient		CPU				Sensor Status Bits							
Bits	Value	Latched	Valid O2	Description											
Bits 15-14	0 (b00)	N/A	Yes	Stack Probe OK											
	1 (b01)	No	Yes	Stack Probe Disconnected Fault											
	2 (b10)	No	Yes	Stack Over Temperature Fault (default 900 °F)											
	3 (b11)	No	Yes	Stack Read Fault (Temperature is at 0 degrees C)											
Bits 13-12	0 (b00)	N/A	Yes	Ambient Temperature OK											
	1 (b01)	No	No	Ambient Temperature Cannot Be Read Fault											
	2 (b10)	No	No	Ambient Over Temperature Fault											
	3 (b11)	No	No	Ambient Under Temperature Fault											
Bits 11-8	0 (b0000)	N/A	Yes	CPU OK											
	1 (b0001)	Yes	No	CPU CRC Fault											
	2 (b0010)	Yes	No	CPU RAM Fault											
	3 (b0011)	Yes	No	CPU Instruction Fault											
Bits 7-0	0 (0x00)	N/A	Yes	Sensor OK											
	1 (0x01)	No	No	Sensor 24 Volt Low Fault (not valid on older hdwr)											
	2 (0x02)	No	No	Sensor 24 Volt High Fault (not valid on older hdwr)											
	3 (0x03)	No	No	Sensor 12 Volt Open Fault (not valid on older hdwr)											
	4 (0x04)	No	No	Sensor 12 Volt Low Fault (not valid on older hdwr)											
	5 (0x05)	No	No	Sensor 12 Volt High Fault (not valid on older hdwr)											
	6 (0x06)	Yes	No	Sensor Unexpected Calibration Fault											
	7 (0x07)	Yes	No	Sensor Stuck Fault (Warm Up, Calibration, etc)											
	8 (0x08)	Yes	No	Sensor Calibration Needed											
	9 (0x09)	No	No	Sensor Heater Short Fault											
	10 (0x0A)	No	No	Sensor Heater Open Fault											
	11 (0x0B)	No	No	Sensor Pump Short Fault											
	12 (0x0C)	No	No	Sensor Pump Open Fault											
	13 (0x0D)	No	No	Sensor Nernst Cell Short Fault											
	14 (0x0E)	No	No	Sensor Nernst Cell Open Fault											
	15 (0x0F)	No	No	Sensor Conversion Timeout Fault											
	16 (0x10)	No	No	Sensor Low Voltage Fault											
	17 (0x11)	No	No	Sensor Too Cold Fault											
	18 (0x12)	No	No	Sensor Too Hot Fault											
	19 (0x13)	No	No	Sensor Air Calibrating											
20 (0x14)	No	No	Sensor Heater Calibrating												
21 (0x15)	No	No	Sensor Comm. Busy												
22 (0x16)	No	No	Sensor Comm. Fault												
32 (0x20)	No	No	Sensor Warming Up												
33 (0x21)	No	No	Sensor in standby												

### Probe Status Register Write

The Probe Status Register is also used to perform functions that modify the state of the O2 Probe. This is accomplished by writing a specific value to the status register using the Modbus Write Holding Register function (**function code 06**).

### Probe Status Register Calibrate

A sensor calibration is performed when the value 0xCACA (51914 decimal) is written to the status register. Note: This should be issued only when there is free air available.

### Probe Status Register Standby On/Off

The sensor is placed into standby mode when the value 0xF0F0 (61680 decimal) is written to the status register. The sensor is taken out of standby by a system reset (User Button), a power cycle, or by writing the value 0x0F0F (3855 decimal) to the register.

Note: When the sensor is placed into standby, the sensor status bits of the status register will indicate the condition unless the register currently contains a higher priority fault.

### Probe Status Register Fault LED Clear

If there is a new O2 Probe fault, Fault LED will be turned on. A clear fault is performed when the value 0xA5A5 (42405 decimal) is written to the status register. Clearing the fault only resets the Fault LED and does not clear the status register nor does it reset the Fault History.

### Stack Temperature Register

The stack temperature is read via the probes thermocouple and has a range from 0 to 1024°C (32 to 1875°F). This Modbus register data is refreshed every second. The register data requires conversion as shown in the following equation...

$$Temp(^{\circ}C) = \frac{\text{Register Value}}{4(\text{decimal})}$$

### Ambient Temperature Register

The ambient temperature (to the sensor board) is read via the probes Ambient Temperature Module that has a range from -55 to 125°C (-67 to 257°F). This Modbus register data is refreshed every second. The register data is a 2's compliment number and requires conversion as shown in the following equation...

$$Temp(^{\circ}C) = \frac{\text{Register Value}}{16(\text{decimal})}$$

### Extended O2 Register

The Extended O2 Register is the direct 2's compliment value supplied by the sensor module when the status registers bits 8 to 11 is equal to 4. This Modbus register data is refreshed every 333 milliseconds. The register data requires conversion as shown in the following equation...

$$Oxygen(\%) = \frac{\text{Register Value}}{100(\text{decimal})}$$

### CO Expansion Registers

These registers are reserved for future use.

### Probe Firmware Revision Register

The Probe Firmware Revision Register contains 2 bytes where the upper byte is the major revision number and the lower byte is the minor revision number. Both values are expressed as ASCII values and are, for unreleased versions, in the range of "A" to "Z" for the major revision number and "a" to



"z" for the minor revision number. Released versions of the firmware have the major and minor revision number range of "0" to "9".

**Probe CRC Register**

The Probe CRC Register contains the stored CRC value of the code space. This is the value that is determined at build time and stored in a protected portion of the ROM space. If a CRC error is detected (the run time CRC calculation of the code space does not match the stored CRC value), then the fault history is updated with a CRC error containing the calculated CRC value so that a fault determination can be made.

**Stack Temp Max Limit Config Register**

The stack temperature, under normal conditions, has a range of 0 to 1024°C (32 to 1875°F). The Stack Temperature Limit Configuration register configures the upper limit alarm setting for the stack bits of the status register. The configured value can be changed by performing a "Holding Register Write" to the register. The default limit is 482°C (900°F). The allowed settings of this register are from 38 to 1024°C (100 to 1875°F). The register data requires conversion as shown in the following equation...

**Register Value**<sub>Upper Limit</sub> = *Upper Limit Temp (°C) \* 4(decimal)*

**Ambient Temp Upper Limit Config Register**

The ambient temperature, under normal conditions, has a range of -55 to 125°C (-67 to 257°F). The Ambient Temperature Upper Limit Configuration register configures the upper limit alarm setting for the ambient bits of the status register. The configured value can be changed by performing a "Holding Register Write" to the register. The default limit is 85°C (185°F). The allowed settings of this register are from 65 to 125°C (149 to 257°F). The register data requires conversion as shown in the following equation...

**Register Value**<sub>Upper Limit</sub> = *Upper Limit Temp (°C) \* 16(decimal)*

**Ambient Temp Lower Limit Config Register**

The Ambient Temperature Lower Limit Configuration register, as with the Ambient Temperature Upper Limit Configuration register configures the lower limit alarm setting for the ambient bits of the status register. The configured value can be changed by performing a "Holding Register Write" to the register. The default limit is -25°C (-13°F). The allowed settings of this register are from -15 to -55°C (5 to -67°F). The register data requires conversion as shown in the following equation...

**Register Value**<sub>Lower Limit</sub> = *Lower Limit Temp (°C) \* 16(decimal)*

**Fault History Registers**

The Fault history is made up of the last ten recorded faults. Each record uses two registers and the registers are updated when the fault is detected. The first register in each record is a compound register and has the following bit definitions...

**Fault History ID Register Bit Positions**

15	14	13	12	11	10	9	8	7	6	5	4	3	2	1	0
Fault Module Bits				Fault Type Bits				Fault Sub Type Bits							

The second register can contain the data that was tested to determine that the fault occurred and is defined by the type of the detected fault.

**Fault History Data Register Bits**

15	14	13	12	11	10	9	8	7	6	5	4	3	2	1	0
Fault Data Bits															



The following table describes the purpose of each bit in each fault history record comprised of the fault history ID register and the fault history data register (all values are in hexadecimal)...

Fault History ID Register			Fault History Data Register Bits (0-15)
Fault Module Bits (12-15)	Fault Type Bits (8-11)	Fault Sub Type Bits (0-7)	
1 (CPU)	0 (ROM CRC)	N/A	Calculated CRC
	1 (Data Overwrite)	N/A	Test Reg 0, Test Reg 1
	2 (RAM)	RAM XOR test position	RAM test position
	3 (Instruction)	N/A	Test Reg 0, Test Reg 1
	4 (State)	Current state	N/A
	5 (Reset)	Reset State 0x01 (HW Reset)	V <sub>dd</sub> Monitor State
		Reset State 0x02 (Vdd Reset)	
		Reset State 0x04 (Missed Clk)	
Reset State 0x08 (Watchdog)			
Reset State 0x10 (SFW Reset)			
Reset State 0x20 (CMP Reset)			
Reset State 0x40 (Flash Err)			
2 (Stack Temp)	0 (Disconnect)	N/A	Stack Temp Data
	1 (Over Heat)		
	2 (Low Temp)		
	3 (Comms)		
3 (Ambient Temp)	0 (No Convert)	N/A	Ambient Temp Data
	1 (Overheat)		
	2 (Low Temp)		
	3 (Comms)		
4 (O <sub>2</sub> Sensor)	0 (Sensor Device)	1 (Heater Short)	Sensor Data
		2 (Heater Open)	
		3 (Pump Cell Short)	
		4 (Pump Cell Open)	
		5 (Nernst Cell Short)	
		6 (Nernst Cell Open)	
		8 (Sensor Time Out)	
		9 (Low Voltage)	
		A (Cold Sensor)	
		B (Sensor Overheat)	
		1 (Comms)	
	1 (Mode Read)		
	2 (Mode Set)		
	3 (Read O <sub>2</sub> )		
	4 (Read Lambda)		
	5 (Read Battery Voltage)		
	6 (Cal Command)		
	7 (Cal Progress)		
8 (Read Error)			
2 (Operations)	0 (Unexpected Cal)	Sensor Data	
	1 (Cal Needed)		
5 (Internal Comm)	0 (Comm Busy)	0 (Stack Device)	Config, Control Register
	1 (Comm Collision)	1 (Ambient Device)	
	2 (Dev Not Ready)	2 (O <sub>2</sub> Device)	
		3 (Data Store Device)	
6 (ModBus)	0 (Min size error)	Last received byte	Buffer size (bytes)
	1 (Max size error)	Last received byte	Buffer size (bytes)
	2 (CRC error)	Buffer size (bytes)	Calculated CRC
	3 (Comm Timeout)	ModBus State	Failed Fault Type Store



---

## NOTICE

When Fireeye products are combined with equipment manufactured by others and/or integrated into systems designed or manufactured by others, the Fireeye warranty, as stated in its General Terms and Conditions of Sale, pertains only to the Fireeye products and not to any other equipment or to the combined system or its overall performance.

---

## WARRANTIES

FIREYE guarantees for *one year from the date of installation or 18 months from date of manufacture* of its products to replace, or, at its option, to repair any product or part thereof (except lamps, electronic tubes and photocells) which is found defective in material or workmanship or which otherwise fails to conform to the description of the product on the face of its sales order. **THE FOREGOING IS IN LIEU OF ALL OTHER WARRANTIES AND FIREYE MAKES NO WARRANTY OF MERCHANTABILITY OR ANY OTHER WARRANTY, EXPRESS OR IMPLIED.** Except as specifically stated in these general terms and conditions of sale, remedies with respect to any product or part number manufactured or sold by Fireeye shall be limited exclusively to the right to replace or repair as above provided. In no event shall Fireeye be liable for consequential or special damages of any nature that may arise in connection with such product or part.



FIREYE  
3 Manchester Road  
Derry, New Hampshire 03038 USA  
[www.Fireeye.com](http://www.Fireeye.com)

NXCES02-1001  
OCTOBER 20, 2011  
Supersedes September 27, 2011