

FIREYE[®] NEXUS and PPC5000 BOILER SEQUENCING

INTRODUCTION

This bulletin (NEX-SO) describes the operation of the FIREYE Nexus / PPC5000 boiler sequencing system. It may be used in conjunction with the following other bulletins:

- NEX-1001, Nexus integrated burner controller commissioning bulletin
- NEX-1501, ComFire combustion analysis tool user bulletin
- PPC-5000, PPC5000 fuel / air ratio controller commissioning bulletin

DESCRIPTION

The FIREYE Nexus and FIREYE PPC5000 burner controllers incorporate a boiler sequencing system as an integral part of their operation. There are fundamentally no differences in the sequencing operation of either type of unit, and an installation may be any mixture of the two.

Up to 10 units may be connected together.



IMPORTANT: This guide covers two different products, hence the parameters to be entered and connector terminal references are different depending on the product used. Where such information is given, it will be given for both types of units in the following format:

.... option parameter 12.0^{Nexus} / 25.0^{PPC5000} must be set to

where the required parameter is 12.0 on a Nexus unit, and 25.0 on a PPC5000 unit.

Connection

The units must be connected together via their RS485 interfaces. The connection is a simple “multi drop” or “daisy chain”, requiring the RS485+ terminals (PD11^{Nexus} / PB1^{PPC5000}) of all units to be connected together, the RS485- terminals (PD12^{Nexus} / PB2^{PPC5000}) of all units to be connected together and the grounds of all units to be connected together (PD10^{Nexus} / PB5^{PPC5000}).

The units at each end of the chain (A and D in this example) should have their RS485 TERM jumpers in the IN position (these are labelled on the BACKPLANE^{Nexus} or BURNER INTERFACE BOARD^{PPC5000}).

FIGURE 1.

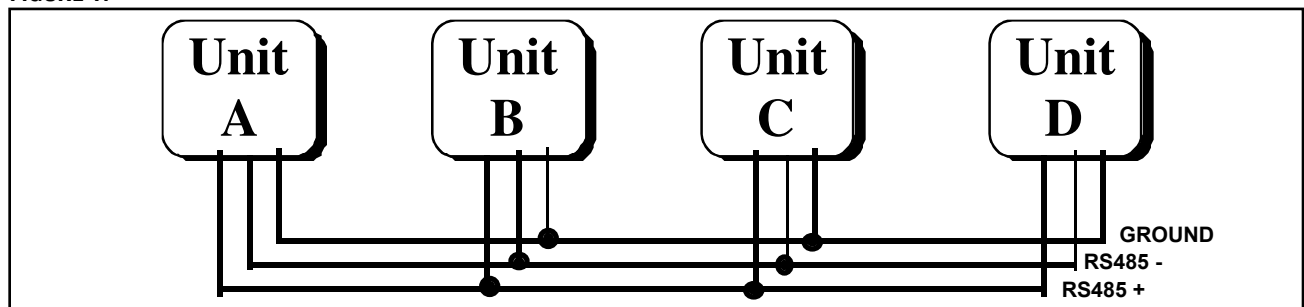



Passcodes

The sequencing feature of both types of unit is enabled by a six-digit passcode.

The comms passcodes have three levels:

- Sequencing only, part number NXSO
- Communications (for ComFire) only, part number NXAM
- Both Sequencing and Communications, part number NXAMS.

For sequencing to work, the passcodes for either “NXSO (Sequencing)” or “NXAMS (Both)” must be entered. For units ordered with these options, the appropriate passcode will be supplied with the unit.

For retro-fit, the engineer must telephone FIREYE with the six digit CPU identification number. This can be found on engineers keys 65 & 66^{Nexus} or 83 & 84^{PPC5000}. He will then be given the numbers to be entered into option parameters 0.5 & 0.6. The unit will need to be powered down then back up again for the passcodes to register.

If the passcodes were correct, the engineers key number 23^{Nexus} / 82^{PPC5000} should show 4, 5, 6, or 7. If it does not, sequencing will not work. Don't worry if the number changes up and down by one number as long as both numbers are in the above range.

Unit Address

Communication between multiple units is made possible by each unit having it's own unique address, such that unit 7 can send a message to unit 3, then unit 3 can send a reply to unit 7.

The unit address for each unit must be entered as option parameter 1.2, and must be a different number for each unit. The range is 0 to 15, but the choice of number is arbitrary, and will have no effect on the operation of sequencing.

Before Continuing...

At this point, a record should be made of the following information for each unit. This information will be invaluable in the event of a problem and will make future service work easier to undertake.

This table is duplicated in the appendix as the first few columns of the “sequencing site record”. A photocopy of that would be ideal to fill out. Here, example information has been added.

| UNIT NAME (e.g. Boiler A) | UNIT ADDRESS 0 to 15 | CPU ID 1 000 to 999 EK 65 ^{NEXUS} EK 83 ^{PPC5000} | CPU ID 2 000 to 999 EK 66 ^{NEXUS} EK 84 ^{PPC5000} | PASSCODE 1 000 to 999 | PASSCODE 2 000 to 999 | COMMS STATUS GREATER THAN 3 000 to 999 EK 23 ^{NEXUS} EK 82 ^{PPC5000} |
|------------------------------|-------------------------|--|--|--------------------------|--------------------------|--|
| BOILER A | 0 | 360 | 987 | 123 | 456 | YES |
| BOILER B | 1 | 000 | 234 | 987 | 654 | YES |
| BOILER C | 2 | 362 | 345 | 789 | 012 | YES |
| BOILER D | 3 | 000 | 456 | 321 | 098 | YES |

SEQUENCING SETUP

Sequence Master (Lead Boiler)

Up to 10 units may be connected together, and any one of these may be designated to be the sequence master. This is the unit that controls all the others, and can be changed at any time either by option parameter, digital input, or remotely from a PC using ComFire software.

Only one boiler may be selected as the master at any time. If more than one master is selected, sequencing will be disabled for ALL boilers, and each will return to using its own local control. A typical installation might use a rotary selector switch that will only allow one boiler to have its digital input energized at a time. See figure 2.

FIGURE 2.

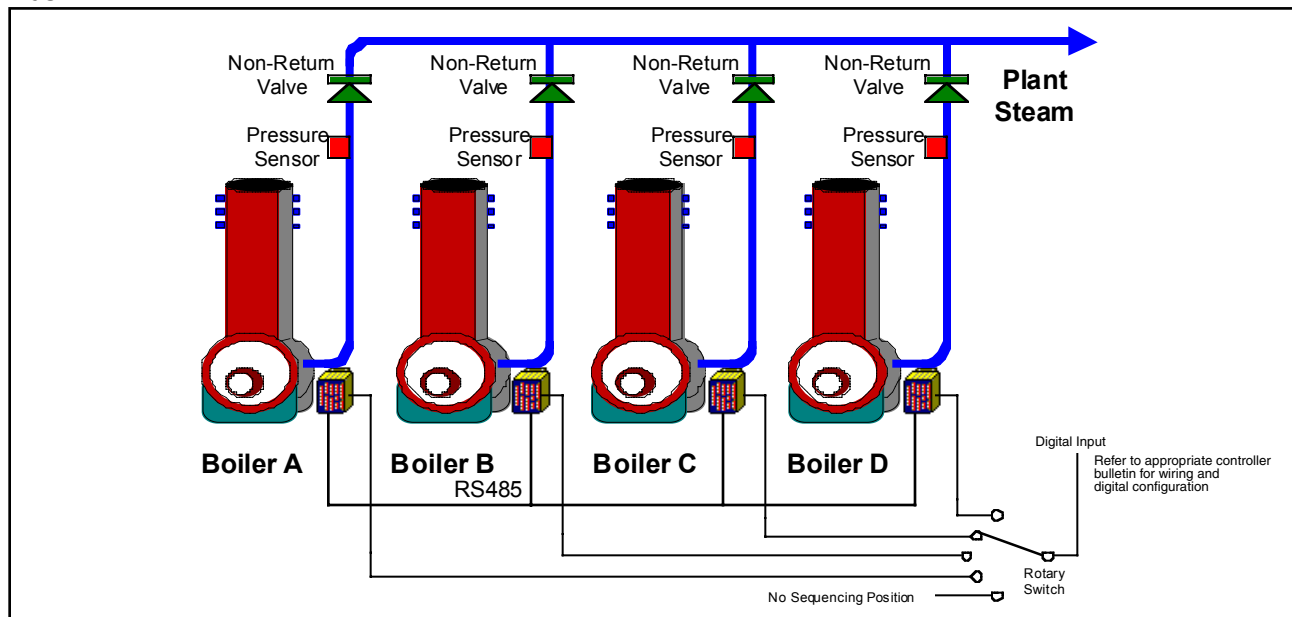

Each boiler has its own pressure sensor and local PID control. When sequencing is not active, each will modulate to attempt to maintain its measured pressure close to its setpoint. If the pressure measured goes above the “High Control Limit”, the burner will turn off until the pressure drops to the “Low Control Limit”.

For the master boiler, this behavior is unchanged during sequencing operation. It still modulates to demand in this way. It will also set the modulation rates of the slave boilers, and turn them on or off as required.

A boiler selected to be the sequence master only remains a master while it is firing. **If it turns off for any reason**, the sequencing system will be disabled, and all slave boilers will come on under their own local pressure control. This is a safety feature, and ensures that the boilers will never go completely cold.

Sequence Slaves

A slave boiler behaves very differently when sequencing is operational.

It will be in one of two states:

1. Off-line

If a slave is commanded to be off-line by the master, it will maintain its measured value to be between the “High Stand-by Limit” (option parameter 12.5^{Nexus} / 26.1^{PPC5000}) and the “Low Stand-by Limit” (option parameter 12.6^{Nexus} / 26.2^{PPC5000}). It will do this by switching on when the pressure falls below the low limit, and remaining at low fire until the high limit is reached.

This is performed so that the slaves can be quickly awakened when the demand increases. If it is known that they will not be needed for a long time (in the summer for example), they should be turned off manually.

2. On-line

If a slave is commanded to be on-line by the master, it will simply fire at the modulation rate that the master commands. However, although its setpoint is ignored, its “High Control Limit” is not. If it’s locally measured pressure goes above the limit that is entered, it will switch off until the pressure drops below the “Low Control Limit”.

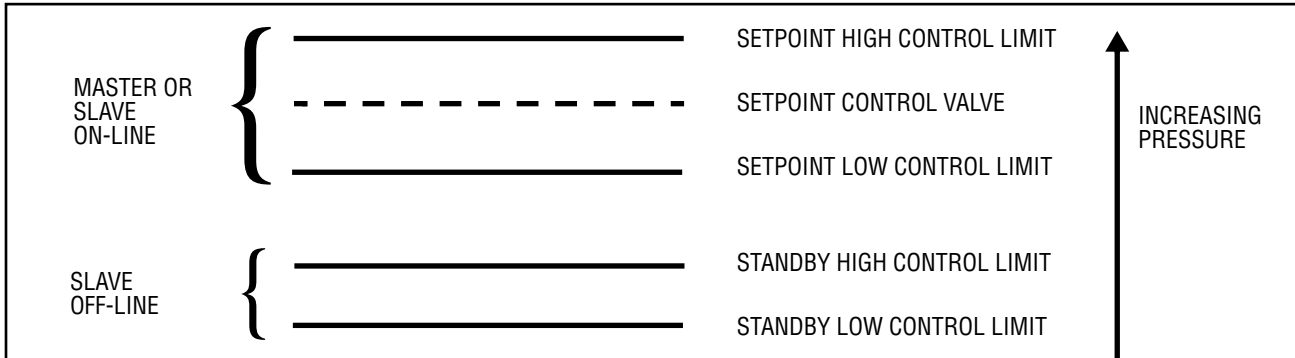

Control Strategy

On Strategy:

Assume that **all slaves are OFF**.

The master boiler measures its own steam pressure and modulates the burner in order to maintain the required steam setpoint under control of a 3-term PID controller. If, in order to achieve this, the output reaches 90% of its maximum continuous rating (MCR is entered by the engineer as an option parameter), it will signal the first slave to come on-line.

A straight-line approximation is used here. If the power output is the low fire power output (option 12.2^{Nexus} / 25.2^{PPC5000}) at 0% modulation, and high fire power output (MCR, option 12.3^{Nexus} / 25.3^{PPC500}) at 100% modulation, it is assumed that a straight line relationship exists between the two.

See “Boiler Priorities” for information as to which slave comes on first.

When the first slave has come on-line, the master and the slave modulate together to maintain the steam pressure at the setpoint. No further slaves will be turned on for at least 10 minutes in order to give this slave a chance to start contributing steam. If, after this time has passed, the combined power output rises to or is still above 95% of the combined maximum continuous rating, another slave (if there is one) will be signalled to come on-line.

When there are three or more boilers firing (including the master), the last two slaves to come on-line will modulate, the other boilers (including the master) will be held at high fire. When these modulating slaves reach 95% MCR, the next slave will be signalled to come on-line if more than 10 minutes have elapsed since the last slave came on-line.

Off Strategy:

In a similar way to the above, no slave will be turned off if it is less than 10 minutes since another was turned off. Also, the master will never be turned off, unless the measured pressure goes above the high control limit.

There are two cases to consider:

1. *Two boilers firing (i.e. master and one slave).*
These two boilers will be modulating together. If their combined power output falls below that which the master boiler could provide at 80% MCR, then the slave will be turned off. The slave will also be turned off if the boilers modulate down to low fire. This is because if the second boiler is a large boiler with a poor turndown, the power given by the master at 80% could be less than can be supplied by both boilers at low fire.
2. *Three or more boilers firing (i.e. master and at least two slaves).*
The master or third from last slave will be at high fire, and the two low priority slaves will be

modulating. If the combined power output of the last three boilers could be provided by switching the last one off, and modulating the other two at 80% MCR or below, then the last slave will be turned off. The last slave will also be turned off it goes to low fire.

Boiler Priorities

Each unit must have a unique priority number, as well as a unique unit address. This number is from 0 to 9 and specifies the order in which the slaves are turned on and off. The next slave to be turned on will always be the “off” slave with priority nearest to the master (ascending). The next slave to be turned off will be the “on” slave with priority furthest from the master.

For simplicity, let us assume that the master is priority 0. The first slave that it would turn on would be the slave with the next lowest priority number, i.e. the slave with priority 2 (unit address 7) in figure 3 below.

FIGURE 3.

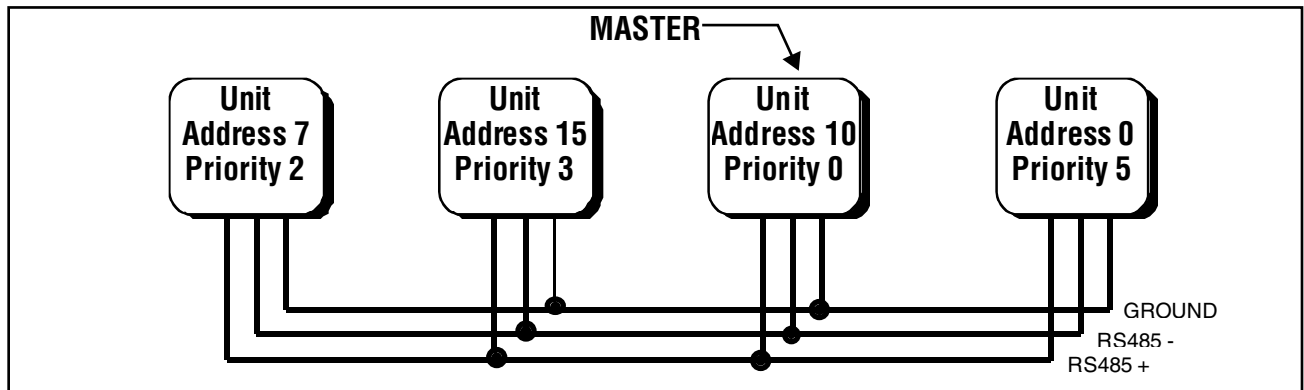

The next slave to fire would be the unit with priority 3. The order of priority for a full system with a master with priority 0 would be:

- Priority 0 (master, always on)
- Priority 1
- Priority 2
- Priority 3
- Priority 4
- Priority 5
- Priority 6
- Priority 7
- Priority 8
- Priority 9 (last boiler to come on)

If the master is not priority 0, however, the priority structure remains with the master at the top, but the last unit will be the one with a priority number immediately below that of the masters. For example if the master has a priority of 5, the order will be:

- Priority 5 (master, always on)
- Priority 6
- Priority 7
- Priority 8
- Priority 9
- Priority 0
- Priority 1
- Priority 2
- Priority 4 (last boiler to come on)

If the master had a priority of 9, the first slave to be turned on would be that with priority 0. This way, by regularly changing the master, all units can receive equal use.



Entering the Parameters

These parameters should be set for each and every unit in the sequencing system. The units may be configured in any order but it is essential to keep a record of all values entered. The table given in the appendix should be filled out as the parameters are entered to ensure this.

Sequence Enable (option 12.0^{Nexus} / 25.0^{PPC5000})

Allowable Range: 0 or 1.

Assuming that the units have been connected together, and the passcodes and unit addresses entered, the first parameter to be entered is the sequence enable parameter. This must be set to 1 on all units to enable access the remainder of the sequencing parameters.

Priority (option 12.1^{Nexus} / 25.1^{PPC5000})

Allowable Range: 0 to 9.

This must be set to a number between 0 and 9 to specify the firing order of the slaves. The number entered **MUST BE UNIQUE FOR EVERY UNIT** otherwise sequencing will not work properly.

Note that the firing order is affected by master selection also.

Low Fire Burner Power Output (option 12.2^{Nexus} / 25.2^{PPC5000})

Allowable range: 0.0 to 99.9 MW

This parameter should be set to the approximate low fire power output of the burner that each unit is connected to. This value will be used, along with the “high fire power” to decide when slaves can be turned on and off. The value does not need to be exact, but a sensible figure must be entered.

The value informs the sequencing system of the turn-down ratio of the boiler. If the maximum power rating is 10.0MW, and the turn-down ratio is 4 to 1 then a value 2.5MW would be entered here.

High Fire Burner Power Output (option 12.3^{Nexus} / 25.3^{PPC5000})

Allowable range: 0.0 to 99.9 MW.

This parameter should be set to the approximate high fire power output of the burner that each unit is connected to (also called Maximum Continuous Rating, MCR). This value will be used, along with the ‘low fire power’ to decide when slaves can be turned on and off. The value does not need to be exact, but a sensible figure must be entered.

Lead Boiler Select (option 12.4^{Nexus} / 25.4^{PPC5000})

Allowable Range: 0 or 1.

This option parameter is one of three ways in which the lead boiler (master) can be selected.

If this option parameter is set to a 1, then this unit will attempt to be the master permanently.

However, if this parameter is 0, the unit can still be a master if:

1. Either auxiliary input is configured as lead boiler select, and the associated input is powered ON.
If option parameter 10.1^{Nexus} / 15.1^{PPC5000} is set to 4, then this unit will be the master if auxiliary input 1 is energized.
If option parameter 10.2^{Nexus} / 15.2^{PPC5000} is set to 4, then this unit will be the master if auxiliary input 2 is energized.
2. The unit is being commanded to be the master via serial comms (e.g. from ComView).

It is important to note that the true master status will be an “OR” function of these options. If any of the lead boiler select methods above give a true result, the unit will attempt to be the master.

SEQUENCING WILL NOT WORK AT ALL IF MORE THAN ONE UNIT IS SELECTED AS THE MASTER.



Standby Low Limit Control Value (12.5^{Nexus} / 25.5^{PPC5000})

Allowable Range: 0 - 999 / 00.0 - 99.9 / 0.00 - 9.99 (depends on setpoint input type).

If the unit is a slave, and is commanded to be in stand-by mode by the master), this is the minimum pressure that the unit will allow its measured value to fall to before starting up and running at low fire to keep its self “warm”.

If this value is set too low, the slave will take a long time to start to contribute steam to the system when it is commanded to be on-line. As well as leading to slow response to an increasing load for the system as a whole, this could result in the master switching on another slave when one is not needed (because the load is not being satisfied quickly enough).

As a rule, the slave should be able to contribute steam to the system well within 10 minutes of being commanded on-line, i.e. the working pressure should be reached.

If this value is set too close to the “Standby High Limit Control Value”, a slave in standby will frequently be turning on and off to attempt stay in the specified range. This is also undesirable.

Standby High Limit Control Value (12.6^{Nexus} / 25.6^{PPC5000})

Allowable Range: 0 - 999 / 00.0 - 99.9 / 0.00 - 9.99 (depends on setpoint input type).

If the unit is a slave, and is commanded to be in stand-by mode by the master, this is the maximum pressure which the unit will allow its measured value to rise to if it has started running at low fire to keep its self “warm”.

If this value is set too low, the slave will take a long time to start to contribute steam to the system when it is commanded to be on-line. As well as leading to slow response to an increasing load for the system as a whole, this could result in the master switching on another slave when one is not needed (because the load is not being satisfied quickly enough).

Also, if this value is set too close to the “Standby Low Limit Control Value”, a slave in standby will frequently be turning on and off to attempt stay in the specified range. This is also undesirable.

However if this value is set to high (too near to the working pressure), energy will be wasted keeping an unnecessarily high pressure in this boiler.

Setpoint High & Low Control Limits (options 7.x, 9.x^{Nexus} / 12.x, 14.x^{PPC5000})

These options are set up in exactly the same way as for a unit without sequencing.

Care must be taken in setting the high control limits, especially for a unit capable of being a master. If a unit's measured pressure reaches its high limit, it will switch itself off. If this unit happens to be a master, this will cause the sequencing to stop until that unit resumes its operation. If this happens, all boilers will come on with their own local PID control enabled.

Typically, the high-pressure limit (of all units) should be 10 to 15 PSI (0.65 to 1 bar) above the masters setpoint, but well below the safety valve opening point. Note that due to “resistance” in the pipes and valves, the actual pressure inside each boiler will in fact be slightly different. In the diagram below, because there is steam flow from left to right, it follows that the pressure must be higher on the left-hand side than it is at the exit.

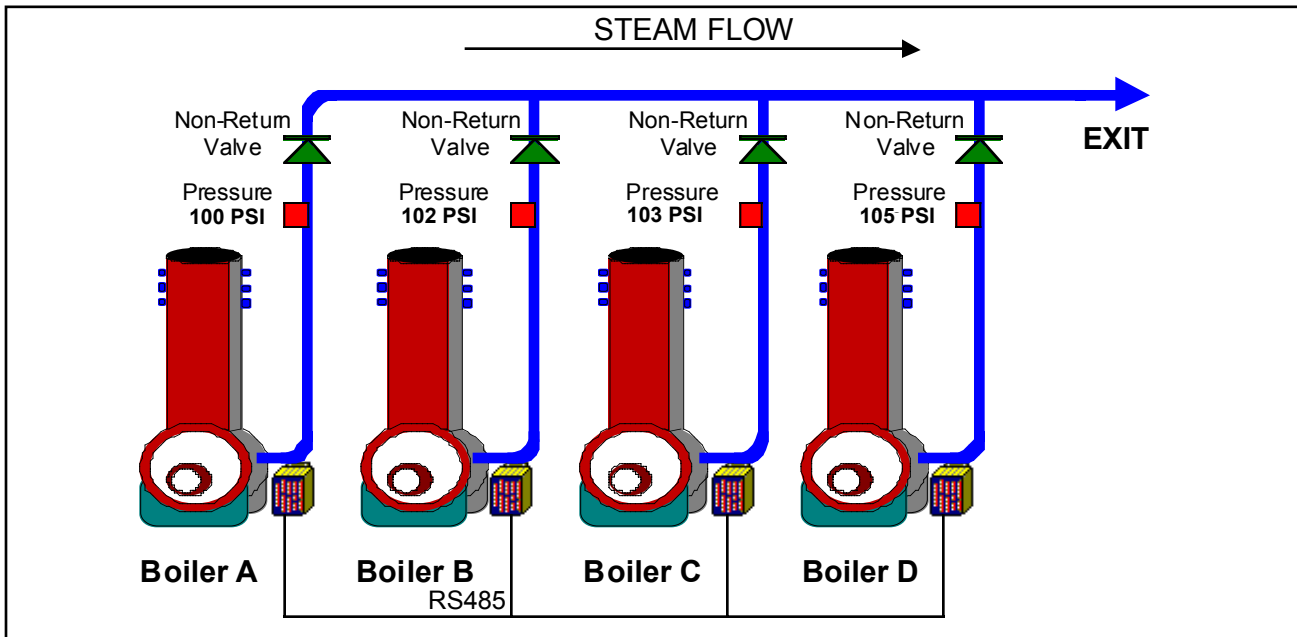

In most cases the effect of this will be negligible, but if the master is boiler D, and the high limit for all units was set to 11 bar, then boiler A would be very close to its limit. A small overshoot caused by a fluctuating load could cause this boiler to trip out.

PID Control Parameters (options 6.x, 8.x^{Nexus} / 11.x, 13.x^{PPC5000})

These parameters are set up in exactly the same way as for a unit without sequencing, but are only used for a particular unit when that unit is the master.

Since the masters' PID control is used to control all units, it is important that it is set-up well. In the figure above, it would be important that the PID control for the master (boiler D) did not cause the pressure to overshoot its setpoint at all, otherwise boiler A would soon shut off (assuming that its high limit is 110 PSI). This might happen if the proportional band was set very low, say 5% or less, as the boiler would remain at high fire until it was almost at the setpoint before rapidly modulating down to low fire.

Remember that it is especially important that the master itself does not lockout. If it does, the whole sequencing system will be temporarily disabled.

Is it Working?

The sequencing system will only work if the units are in "AUTO" mode. If the sequencing system is working, all units (master and slaves) will have their "AUTO" lights flashing. This is, however, no indication that the system is working well.

Tuning

The optimum configuration of the sequencing system will depend greatly on the particulars of each site. The pattern of load change will have a great effect, if the load changes quickly, the stand-by pressures of the slave boilers may need to be quite high to ensure fast response.

The time between successive boilers turning on or off can be adjusted via option parameter 12.7^{Nexus} / 25.7^{PPC5000} (in master unit). As default, this is set to 10, meaning that once a boiler has been turned on, another will not come on for 10 minutes. In addition, if a boiler is turned off, another will not go off for 10 minutes.

If it is found that the system cannot keep up with large load changes, this parameter could be reduced to 5, meaning that the next boiler will only be held off for 5 minutes.

Conversely, it may be found that often a boiler comes on, and before it fully starts to contribute steam, another comes on, which is then soon shut down. This parameter could be increased to 15 to hold off the second boiler for longer.

Great care must be taken over the correct settings for pressure limits and PID parameters, especially for quickly varying loads, but in some cases the ideal settings may be best found by experimentation.

TROUBLESHOOTING

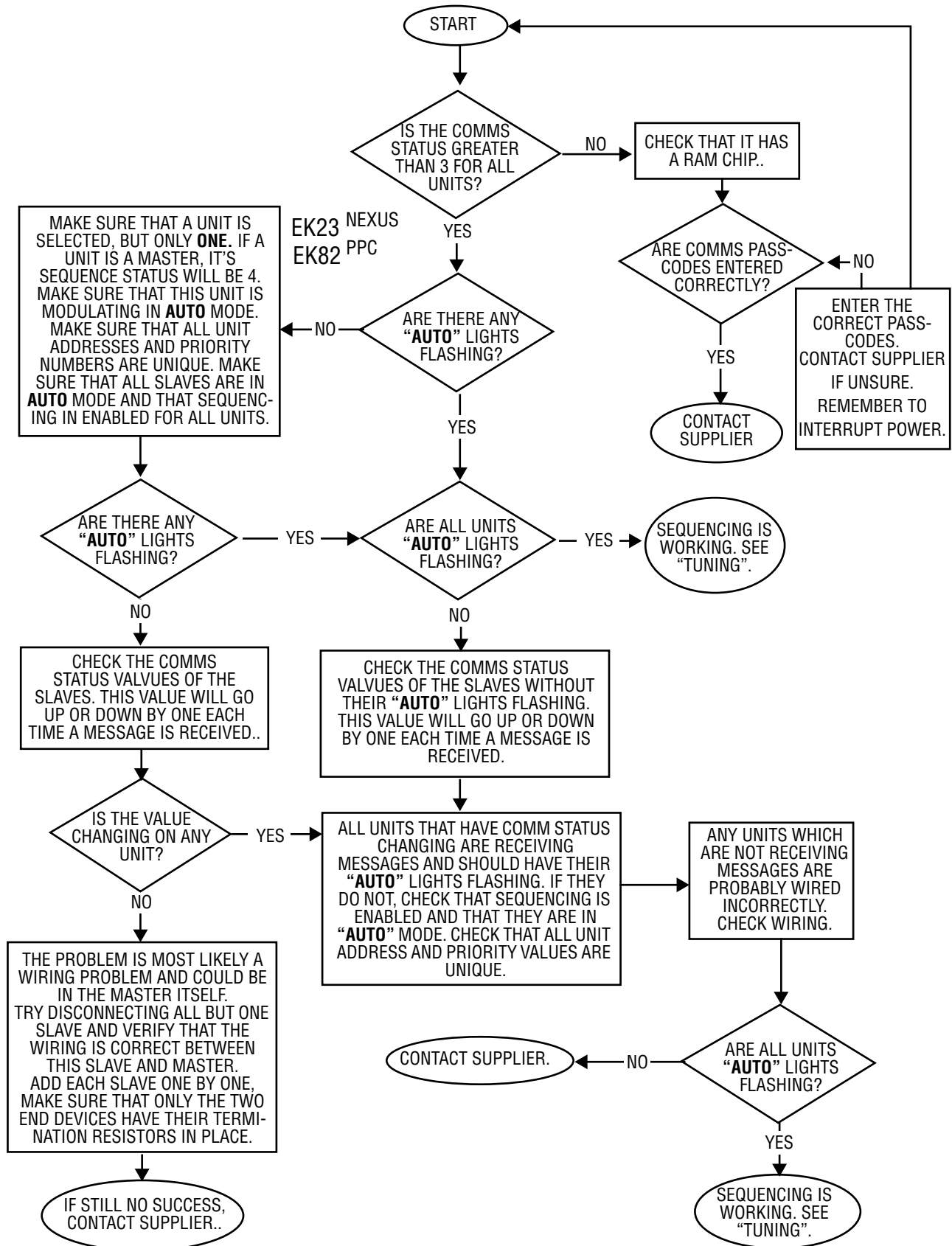



NOTES



NOTES



NOTICE

When Fireeye products are combined with equipment manufactured by others and/or integrated into systems designed or manufactured by others, the Fireeye warranty, as stated in its General Terms and Conditions of Sale, pertains only to the Fireeye products and not to any other equipment or to the combined system or its overall performance.

WARRANTIES

FIREYE guarantees for *one year from the date of installation or 18 months from date of manufacture* of its products to replace, or, at its option, to repair any product or part thereof (except lamps, electronic tubes and photocells) which is found defective in material or workmanship or which otherwise fails to conform to the description of the product on the face of its sales order. **THE FOREGOING IS IN LIEU OF ALL OTHER WARRANTIES AND FIREYE MAKES NO WARRANTY OF MERCHANTABILITY OR ANY OTHER WARRANTY, EXPRESS OR IMPLIED.** Except as specifically stated in these general terms and conditions of sale, remedies with respect to any product or part number manufactured or sold by Fireeye shall be limited exclusively to the right to replacement or repair as above provided. In no event shall Fireeye be liable for consequential or special damages of any nature that may arise in connection with such product or part.



FIREYE®
3 Manchester Road
Derry, New Hampshire 03038 USA
www.fireeye.com

NEX-S0
MAY 2002

