



Fireeye NEXUS[®] NX98 -1, -2 Servo Motor Installation

DESCRIPTION

This manual describes the installation and provides operating instructions for the NX98 - 98Nm/73 lb.-ft. servo motor.

Other servo motor manuals are:

NEX-2004 - 4Nm/3 lb.-ft. servo motor

NEX-2020 - 20Nm/15 lb.-ft. servo motor

NEX-2050- 50Nm/37 lb.-ft. servo motor

SAFETY INFORMATION



WARNING: When this equipment is mounted on an appliance, all external timers/controllers must be listed or component recognized by authorities who have jurisdiction for the specific purpose for which they are used.

Before attempting to install, commission or operate this equipment, all relevant sections of this document must be read and fully understood, failure to follow them could damage the product or cause a hazardous condition. If in doubt about any requirement contact the supplier.

Check the ratings in these instructions to ensure the product is suitable for your applications.

Installation, commissioning or adjustment of the product, **MUST** be carried out by suitably trained mechanical and electrical engineers or personnel qualified by training and experience.

After installation is complete, check that the product operation is as described in this bulletin.

The manufacturer of this equipment accepts no liability for any consequences resulting from inappropriate, negligent or incorrect installation, commissioning or adjustment of operating parameters of the equipment.

This equipment must only be mounted onto burners as detailed in the contract specification. The supplier must approve any change in the specification in writing.

Control covers must not be left off while power is on. If it is essential to do so while rectifying faults only personnel qualified by training and experience should be involved.

The time any covers are off must be kept to a minimum and warning notices must be posted.

Before attempting any work on this equipment, the electrical supplies must be isolated.

Safety devices must not be removed or over-ridden. Any faults once detected must be corrected before the unit is operated.

APPEARANCE AND NOMENCLATURE

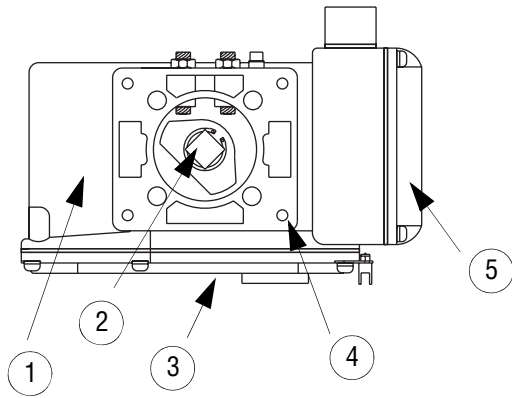

No	Name
1	Body
2	Position Indicator
3	Drive Unit Cover
4	Power Instrument Cover
5	Control Unit Cover
6	Output Shaft
7	Manual Handle
8	Conduit Entry 1/2" NPSL

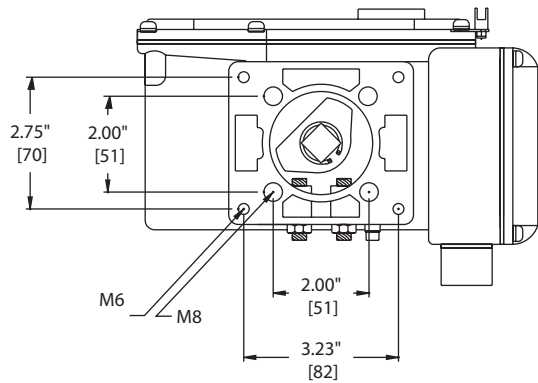
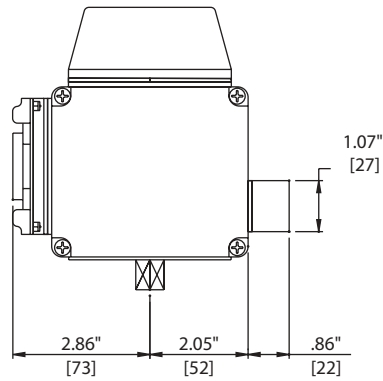
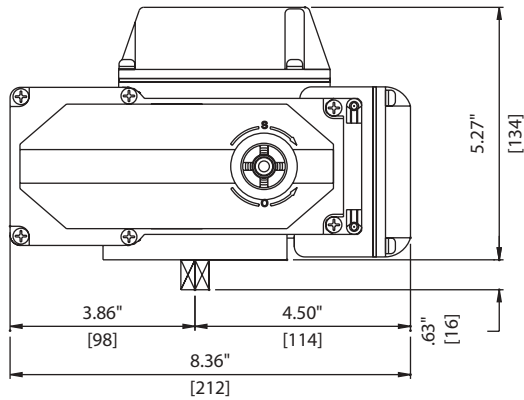
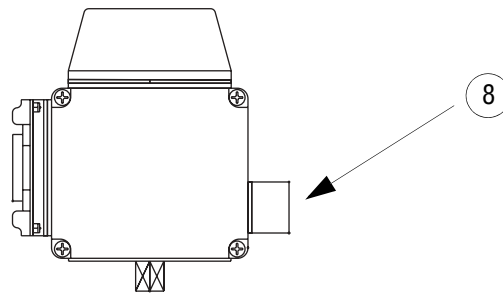
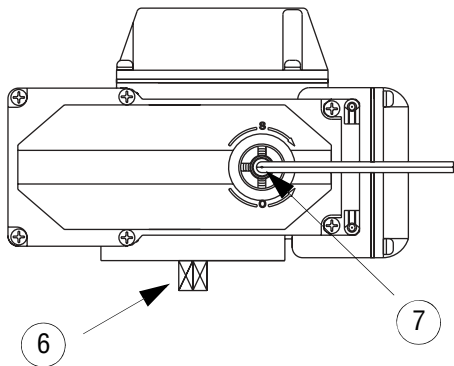

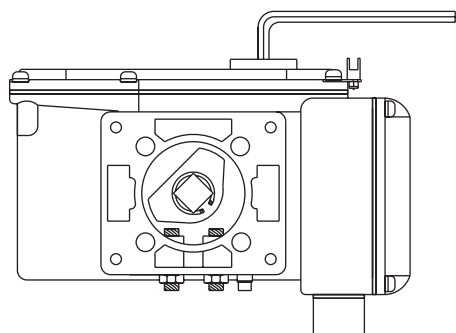
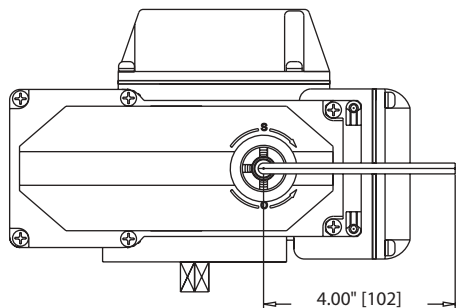

- Before starting manual operation, check that the power source is switched off.
- Remove rubber cap of the drive unit and insert the manual handle into the hexagonal hole.
- Turn the manual handle clockwise and the shaft moves to close direction.

•DO NOT overturn the handle with excessive force as this may cause damage to the other parts.

Dimensions of Manual Handle

Opposite side of hexagon	5mm
Number of turns	15
Length of handle	100mm

Maintenance

Lubrication: Since the unit is sufficiently lubricated with a long life and pressure proof di-sulfide molybdenum grease (MOS2), no further lubrication is required.

Periodical Test: In case the motor is very seldomly rotated, it is suggested to have a periodical test and check if there is no irregularity

NX98 WIRING FOR NEXUS 3100 & 4100

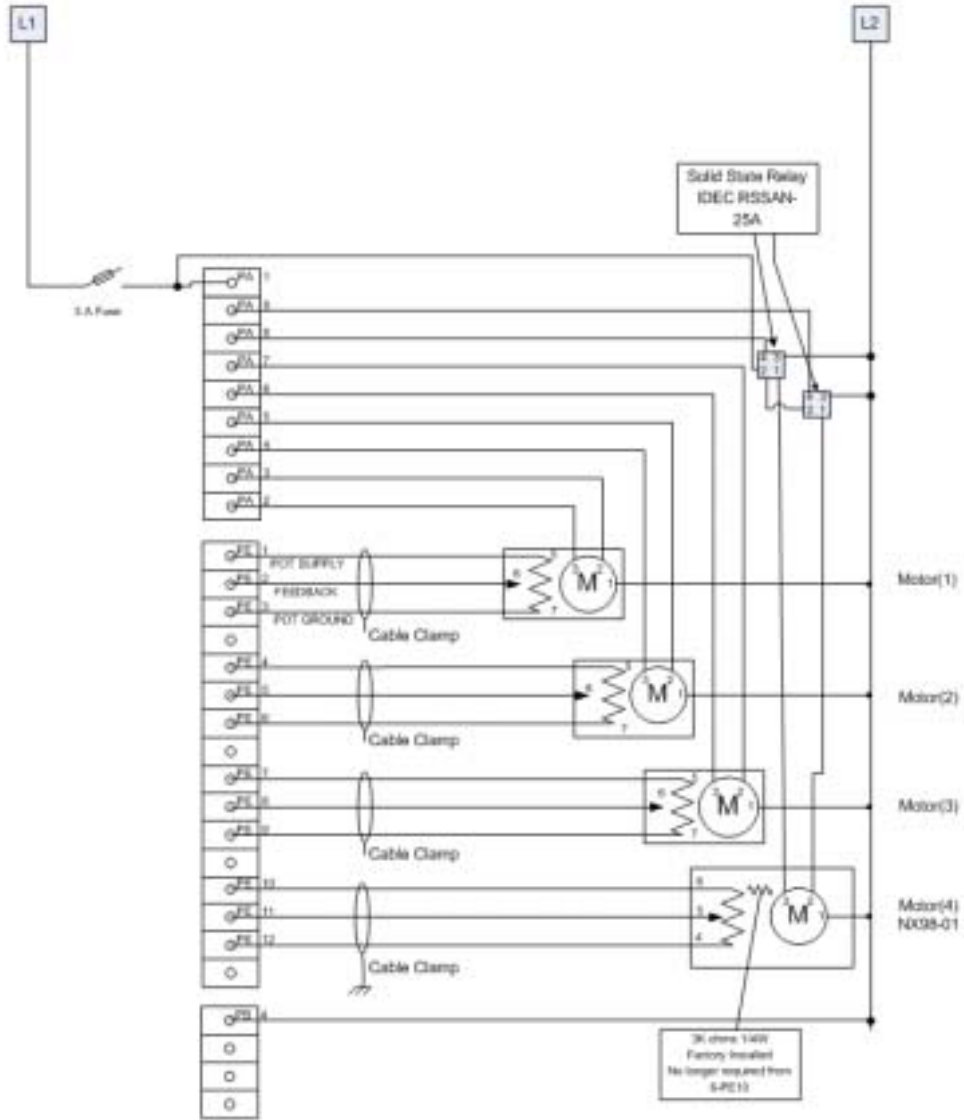

Note: Prior to the date code 0630, the 3K ohm resistor was supplied for external connection from the Potentiometer Supply to terminal 6 the NX98 motor. From the date code 0630, the resistor is supplied factory mounted between terminal 6 and the input to the feedback pot as shown above.

If you are replacing an earlier version motor, remove the resistor which is located between the 15v output in the control to terminal 6 in the NX98 motor.

NX98 WIRING FOR PPC 5000

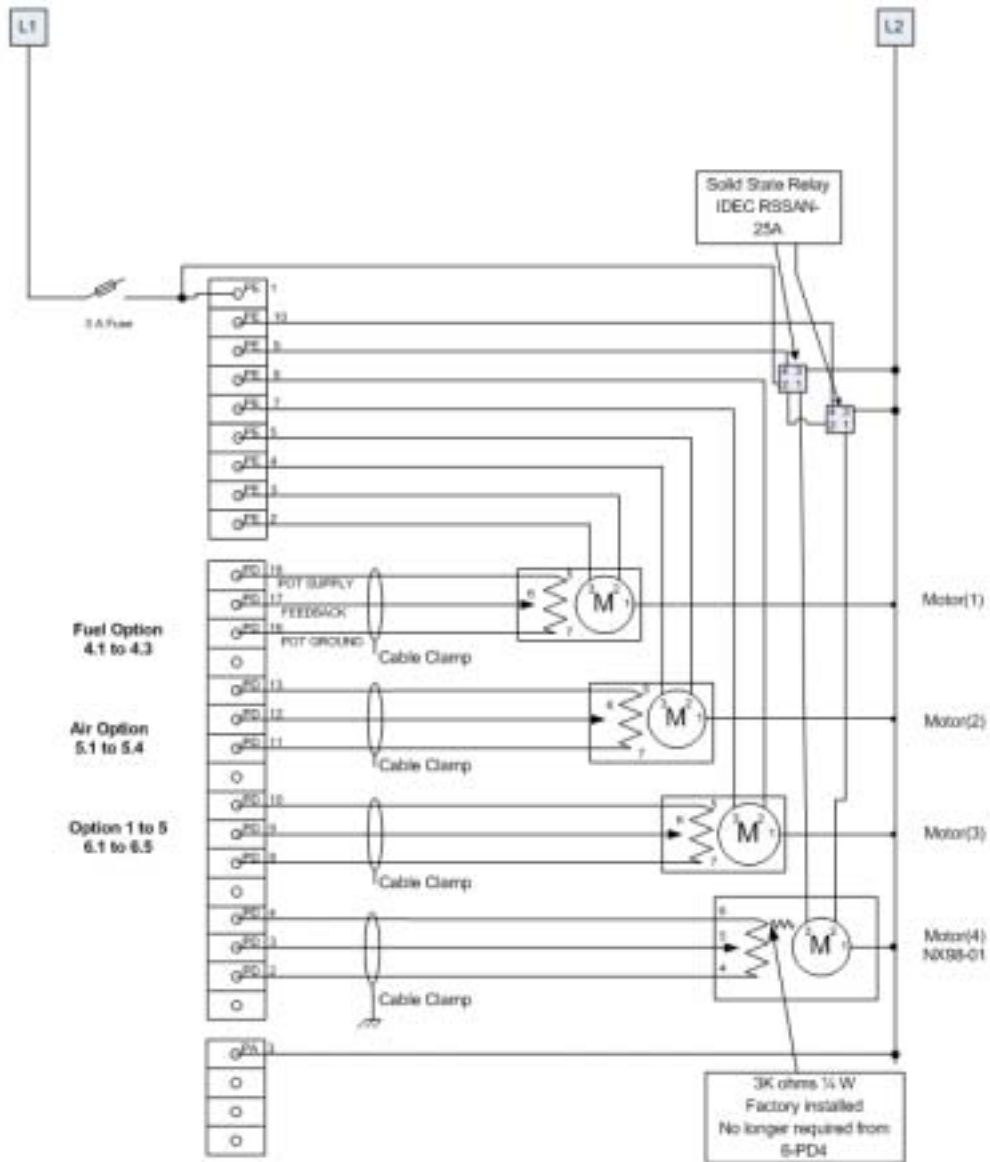

Note: Prior to the date code 0630, the 3K ohm resistor was supplied for external connection from the Potentiometer Supply to terminal 6 the NX98 motor. From the date code 0630, the resistor is supplied factory mounted between terminal 6 and the input to the feedback pot as shown above.

If you are replacing an earlier version motor, remove the resistor which is located between the 15v output in the control to terminal 6 in the NX98 motor.



NOTICE

When Fireeye products are combined with equipment manufactured by others and/or integrated into systems designed or manufactured by others, the Fireeye warranty, as stated in its General Terms and Conditions of Sale, pertains only to the Fireeye products and not to any other equipment or to the combined system or its overall performance.

WARRANTIES

FIREYE guarantees for *one year from the date of installation or 18 months from date of manufacture* of its products to replace, or, at its option, to repair any product or part thereof (except lamps and photocells) which is found defective in material or workmanship or which otherwise fails to conform to the description of the product on the face of its sales order. **THE FOREGOING IS IN LIEU OF ALL OTHER WARRANTIES AND FIREYE MAKES NO WARRANTY OF MERCHANTABILITY OR ANY OTHER WARRANTY, EXPRESS OR IMPLIED.** Except as specifically stated in these general terms and conditions of sale, remedies with respect to any product or part number manufactured or sold by Fireeye shall be limited exclusively to the right to replacement or repair as above provided. In no event shall Fireeye be liable for consequential or special damages of any nature that may arise in connection with such product or part.



FIREYE™
3 Manchester Road
Derry, New Hampshire 03038 USA

NEX-2098
DECEMBER 7, 2006