



MOD-6001  
MARCH 15, 2010

# **NEXUS NX6100/PPC6000 SERIES MODBUS COMMUNICATIONS**

---

## **DESCRIPTION**

The MODBUS interface is designed to connect Fireeye's NX6100 or PPC6000 Nexus Controllers to other devices using the 'MODBUS RTU' protocol, using 3 wire RS485. This bulletin shows connections and the available MODBUS memory map for these controls only.

NX6100/PPC6000 series controllers may be connected to a MODBUS communications system to enable data collection and limited control functions. The controllers are connected to the MODBUS via the Isolated RS485 Communications terminals on the NX6100 or PPC6000. The MODBUS function requires a daughter board to be fitted to each controller.

The protocol supported is MODBUS RTU and the data configuration supported is 8-bits, no parity, 1-stop bit. This is the simplest and most common data configuration because the MODBUS protocol includes 'crc' to ensure data packet integrity.

A network of up to 14 Fireeye Nexus NX6100 or PPC6000 controls can be linked to MODBUS.

Consideration needs to be given to the total number of registers to be communicated, refer to page 4 for further details.

MODBUS RTU can be accessed via two daughter boards for the NX6100 or PPC6000. The NXDBMB (MODBUS only) or NXDBVSD (MODBUS and variable speed drive) allow access to the NX6100/PPC6000 through the isolated RS485 terminals. See Figure 1, Section 1.2. Also, refer to the appropriate bulletin, NEX-6101 or PPC-6001.



---

## Safety information

---



### ***WARNING***

The equipment described in this manual is capable of causing property damage, severe injury, or death. It is the responsibility of the owner or user to ensure that the equipment described herein is installed, operated and commissioned in compliance with the requirements of all national and local legislation, which may prevail.

When this equipment is fitted to an appliance due regard must also be given to the requirements of that appliance.

**Before attempting to install, commission or operate this equipment all relevant sections of this document must be read and fully understood. If in doubt about any requirements consult Fireeye.**

**Installation, commissioning or adjustment of this product MUST be carried out by suitably trained engineers or personnel qualified by training and experience.**

**After installation or modifications to the installation all functions of the equipment MUST be checked to ensure safe and reliable operation of the control.**

The manufacturer of this equipment accepts no liability for any consequences resulting from inappropriate, negligent or incorrect installation, commissioning or adjustment of operating parameters of the equipment.

Control panels **must not** be left uncovered while power is on. If it is essential to do so while rectifying faults only personnel qualified by training and experience should be involved.

The time any covers are off must be kept to a minimum and warning notices **must** be posted.

Before attempting any work on this equipment or any equipment controlled by or connected to this equipment, all related electrical supplies **must** be isolated.

Safety interlocks **must not** be removed or over-ridden. Any faults once detected **must** be corrected before the control is operated.

The manufacturer of this equipment has a policy of continual product improvement and reserves the right to change the specification of the equipment and the contents of this manual without notice.



---

# Table of contents

---

Please read the safety information at the front of this manual before proceeding.

---

<b>1. Introduction.</b>	<b>5</b>
1.1 Compatibility and Conventions	5
1.2 Overview	5
<hr/>	
<b>2. Wiring and Hardware Configuration</b>	<b>6</b>
2.1 MODBUS cables	6
2.2 Screen termination	6
2.3 RS485 serial communications termination resistor	7
<hr/>	
<b>3. Controller configuration.</b>	<b>8</b>
3.1 Overview	8
3.2 Entering the Parameters	8
3.3 General	8
3.3.1.1 Entering commission ratio mode	9
3.3.1.2 Exiting from commission mode	9
<hr/>	
<b>4. MODBUS Data Sets</b>	<b>11</b>
4.1 Overview.	11
4.2 MODBUS system reset and timeout	12
4.3 Coils (0XXX(X)) – WRITE TO registers (MODBUS Function Code 5)	12
4.4 Input Registers (3XXX(X)) – READ FROM (MODBUS function code 4)	13
4.5 Holding Registers (4XXX(X)) – WRITE TO (MODBUS function code 6)	16
<hr/>	
<b>5. Specification.</b>	<b>17</b>
<hr/>	
<b>6. Appendix - Communications</b>	<b>18</b>
6.1 E110 Flame Monitor.	18
6.2 YB110 BurnerLogix.	24

# 1. Introduction.

## 1.1 Compatibility and Conventions

MODBUS RTU communication with NX6100/PPC6000 series controllers is compatible with NX6100 or PPC6000 at firmware revision 1.2 or greater. Engineer's Key EK55 indicates the firmware version. See Section 4 and 6.6 of the relevant NX6100 or PPC6000 bulletin for more information. The NX6100/PPC6000 require the use of either the NXDBMB (MODBUS only) or the NXDBVSD (MODBUS and Variable Speed Drive) daughter boards. These boards are inserted into the NX6100/PPC6000 through the back side. The firmware revision of these boards must be 1.103 or above. Consult the factory to verify the revision level.

This guide covers several different products; hence the parameters to be entered and connector terminal references may be different depending on the product used. Where such information is given, it will be given for both types of controllers in the following format of the following example:

.... option parameter 12.0<sup>6000</sup> / 13.0<sup>6100</sup> must be set to ....

where the required parameter may be 12.0 on a PPC6000, and 13.0 on an NX6100 controller.

## 1.2 Overview

NX6100/PPC6000 series controllers may be connected to a MODBUS communications system to enable data collection and limited control functions. The controllers are connected to the MODBUS via the Isolated RS485 Communications terminals on the controller, not the daughterboard. The MODBUS function requires a daughter board to be fitted to the controller.

The protocol supported is MODBUS RTU and the data configuration supported is 8-bits, no parity, 1-stop bit. This is the simplest and most common data configuration because the MODBUS protocol includes 'crc' to ensure data packet integrity.

NX6100/PPC6000 series controllers support 2-wire MODBUS, which in fact is often a 3-wire system where the 3<sup>rd</sup> wire is a 0V logic connection. This is the preferred wiring method. The MODBUS cable loops from one device to the other, a 'daisy chain' configuration as shown below.

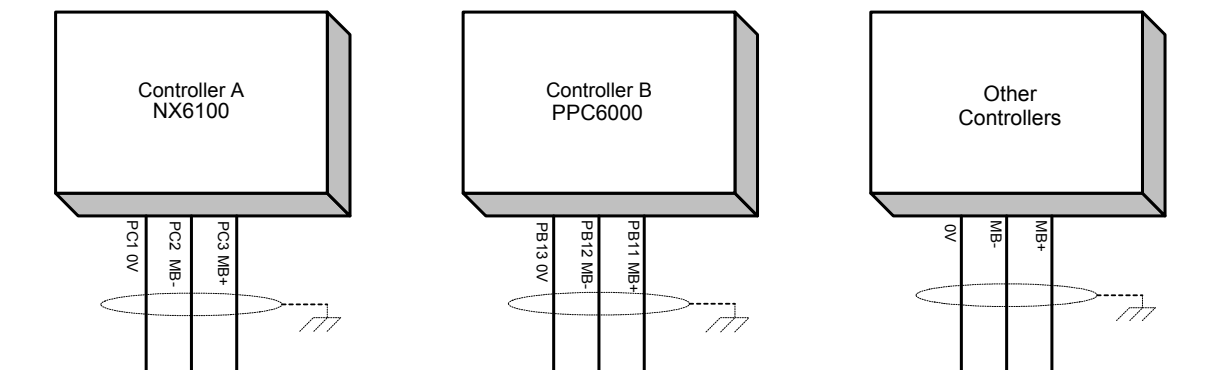

Figure 1: MODBUS Connections

Commands via MODBUS are only valid when the NX6100/PPC6000 series controller is in Normal/Remote operating mode as selected from the display. See the relevant NX6100 or PPC6000 bulletin for more information.

## 2. Wiring and Hardware Configuration

### 2.1 MODBUS cables

FIREYE recommends that RS485 MODBUS cables should be overall 'braid' screened, PVC insulated, 3-core of 24 AWG (7/0.2mm) wire minimum. This cable may be run adjacent to, and/or in the same conduit as high voltage wiring. Therefore, the cable voltage rating must exceed the maximum voltage carried by any other cable connected to the controller or run in the same conduit.

Terminate the screen **at each controller** using the cable clamps provided. **Incorrect connection or application of excess voltage may damage or destroy the controllers being connected.**

### 2.2 Screen termination

Screen termination clamps are provided on the main controller for termination of cable screens (tinned copper braid type). It is important to ensure that the screen and associated insulation cover the cable cores as close as possible to the terminals to which they are connected, and **not** cut-back to where the cable passes through the screen termination clamp.

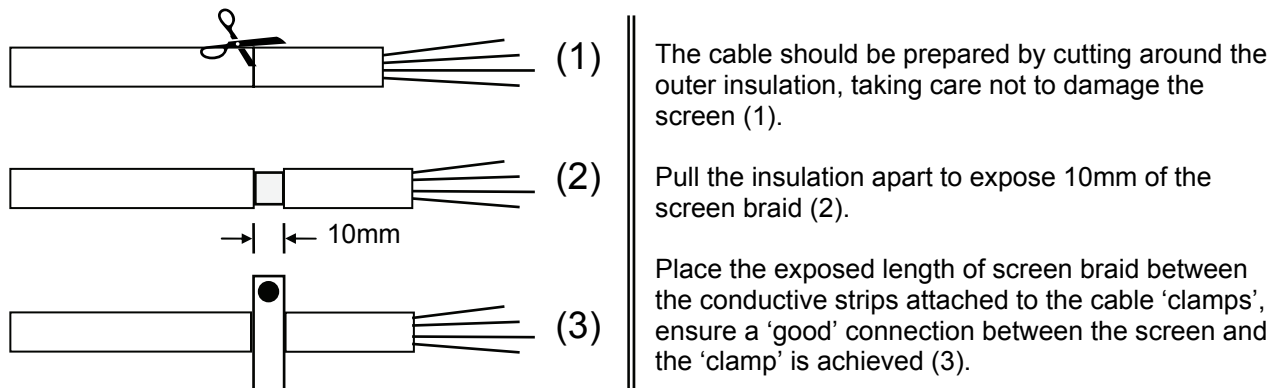

The cable should be prepared by cutting around the outer insulation, taking care not to damage the screen (1).

Pull the insulation apart to expose 10mm of the screen braid (2).

Place the exposed length of screen braid between the conductive strips attached to the cable 'clamps', ensure a 'good' connection between the screen and the 'clamp' is achieved (3).

**NOTE:** The 'clamps' are not intended to provide strain relief for the cables.

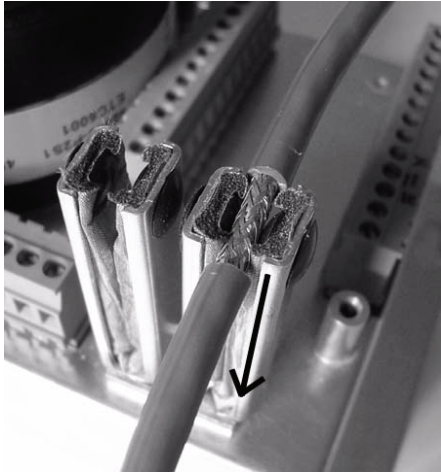

### 2.3 RS485 serial communications termination resistor

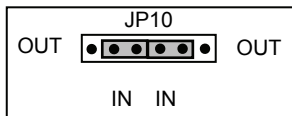

RS485 communication buses require balancing. This is achieved by applying termination resistors at the extremes of the cable. There are two resistors, one for each of the RS485 + and – wires. NX6100/PPC6000 series daughter boards have termination resistors on-board, which are selected by JP1 jumpers on the daughter board.

If a FIREYE device is at the end of the bus then set both of the JP1 links to the IN position. All other controllers should have the links set to the OUT position. If only two controllers are on the communications bus, set the termination resistors on both controllers to the IN position.

**NOTE:** The ‘clamps’ are not intended to provide strain relief for the cables.

## 3. Controller configuration.

### 3.1 Overview

Before configuring the NX6100/PPC6000 series controllers for MODBUS communications, the user must have a clear operating strategy defined. This strategy should define the operating speed of the bus, the bus addresses for each device on the bus and the data sets required of each bus device. Only when this information is clear should the system option parameters be set and the MODBUS system tested against the operating strategy.

### 3.2 Entering the Parameters

The NX6100/PPC6000 series controllers require configuration to match the MODBUS. Device address and communications speed are configured by setting option parameters in the controller. These parameters must be set for each and every NX6100/PPC6000 series controller on the MODBUS and are programmed when the controller is in Commissioning mode.

The controllers may be configured in any order but it is important to keep a record of the values programmed into each controller.

### 3.3 General

If any settings in the control are to be changed, it is necessary to enter a commission mode. Three passcodes are available for this purpose, shown as LV1 (Level 1), LV2 (Level 2), and LV3 (Level 3) in this manual

- *Supplier passcode* – LV3 – allows entry to all commissioning modes.
- *Adjust ratio passcode* – LV2 -- allows adjustment of some option parameters and entry to adjust ratio mode.
- *Site passcode* – LV1 -- allows adjustment of some option parameters.

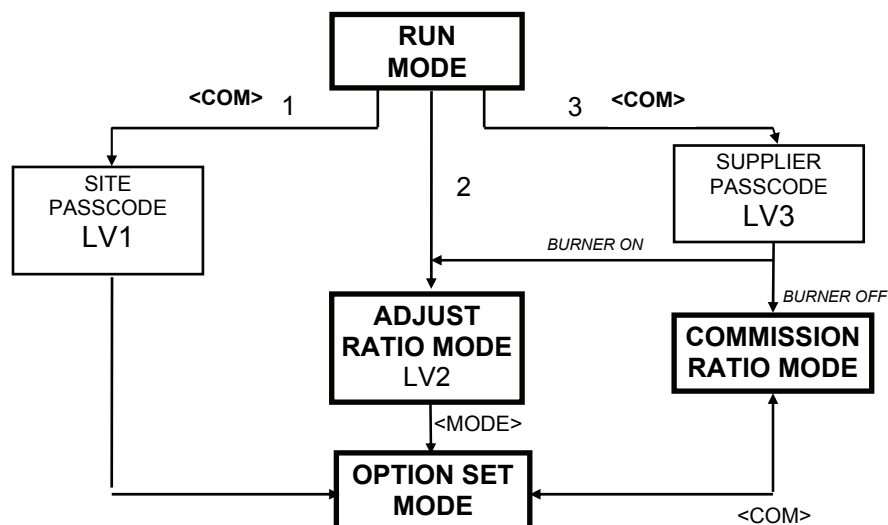

### 3.3.1.1 Entering commission ratio mode

To enter commission mode, press the key labeled **COM** and select the site passcode value using the **UP/DOWN** keys. The site passcode has a factory default setting of 154. Enter this value as shown below.



\* - **NOTE: If the site passcode has been changed, you will have to enter that number.**

### 3.3.1.2 Exiting from commission mode

To exit from any commission mode to run condition, press the key labeled **RUN** and then **ENTER**.

- Use the UP/DOWN keys to change the value of the option parameter. When the correct value is selected then press the ENTER key to store the new value.
- Set or adjust all of the parameters as required by moving between the parameters and adjusting as detailed above.

e.g.



### 5.4.1 Option parameter list



## **CAUTION**

- Use extreme care when entering option parameters. Incorrect data entry could cause a hazardous situation to occur.
- It is possible that additional parameters may be present in the unit depending on the application and/or supplier.

**Note: Option parameters are marked with LV1, LV2, and LV3, which indicate what level passcode is required. If, when using the supplier passcode (LV3), it is not possible to adjust the value of an option parameter, then the burner must be turned off to make the adjustment.**

#### Option 00.1 - Site passcode (0 - 999) LV3

This is a three digit passcode that will allow the site engineer or end-user to enter option set mode and adjust a limited range of option parameters (those not marked with 'LV2' or 'LV3' in this section). This passcode can be zero, in which case the user only needs to press the COM / ENTER key twice to enter option set mode with limited access. Factory default is 154.

### Option 00.2 - Serial communications control address (0 - 15) LV1

If the control is to be connected to other equipment via the serial communications interface, it must be given a unique address using this option parameter. Additionally if more than one control unit is connected on the CAN bus (for example to share a display), the units must all have unique addresses BEFORE THEY ARE CONNECTED TO THE SAME CANbus. **This passcode is used with Comfire or sequencing and is not part of the MODBUS RTU setup.**

### Option 00.7 – MODBUS device address (1 – 99) LV3

Default value is 0= OFF

This option sets the MODBUS device address for the controller and must be unique for each device on the bus.

### Option 00.8 – MODBUS communications speed (0 – 3) LV3

Default value 0

This option sets the MODBUS communications speed in each controller as follows:

Option 00.8 value	Speed, bits/s
0	9600
1	4800
2	9600
3	19200



---

## 4. MODBUS Data Sets

---

### 4.1 Overview.

The NX6100/PPC6000 series controllers support the following MODBUS register types :

- Coils (1 to 19) - These registers can be written to by a MODBUS master to provide control of NX6100/PPC6000 series controllers. In addition these registers can be read to interrogate the last value written.
- Input registers (1 to 1200, 16 bit) - These can be read by a MODBUS master to monitor combustion and other variables, from the NX6100/PPC6000 series controllers.
- Holding registers (1 to 1600, 16 bit) - These can be written to by a MODBUS master to change modulation control of NX6100/PPC6000 series controllers. As with Coils, these registers can be read to interrogate the last value written.

For daughterboard firmware levels 1.103 and greater, the MODBUS system can keep a maximum of 100 items (including read and written items) updated. Values will normally all refresh within one second, but if more than 50 items are being updated, this will extend to two seconds.

Only the last 100 registers requested from the MODBUS master will be remembered by the NX6100/PPC6000 controller. If more than 100 items are requested, the oldest items will cease to be active. This means that if more than 100 different items have been accessed since a particular item was read, this item may return zero the next time it is read, since the MODBUS system is no longer tracking that item. It will then become active and will hold valid data on the next read. In practice this is not an issue since there are nowhere near 100 items available from the NX6100/PPC6000 series controllers that will be of interest to plant operators etc. Most values that are available are 'engineers key' values that are provided for fault-finding and diagnostic purposes.

However, Coils and Holding registers are never 'dropped' from the item list in this way. So if the burner is turned off via MODBUS (for example), then 100 or more different read items are requested but the 'burner off' register is not updated, the burner will stay off.

The MODBUS 'read' functions listed in section 4.4 below allow multiple items to be read in one MODBUS request. However the maximum size of MODBUS messages is limited to 128 bytes. The maximum number of items that can be read in one message is 61, but it is recommended that significantly fewer registers are read. Again, this many contiguous registers will not all contain useful data anyway.

**Note: Check daughterboard firmware level if Option 0.7 and 0.8 are correctly set and the MODBUS message structure has been verified as correct.**

All address references in the MODBUS messages use numbers relative to zero. For example, the first holding register SETPOINT 1 CONTROL VALUE, would be 40001 and be referenced as register 00. Similarly, coil 00008, BURNER ON/OFF, would be register 07.



## 4.2 MODBUS system reset and timeout

It is possible to change operational parameters of the burner / boiler by writing to coils and holding registers (see following sections). Once one of these registers is written to, it will become 'active' and start to control the burner using the data written to it.

This register will remain 'active' controlling the burner forever unless there is no MODBUS communication to this slave for three minutes. So, if there are no MODBUS read requests or write requests for three minutes, all control functions will be disabled and the FIREYE controller will operate in its default or local state.

As soon as communication resumes (even if just one register is read), the system will remember the active control register setting from before and those values previously written will be asserted once more.

Note : For daughterboard firmware levels less than 1.103, the timeout mechanism is slightly different – each MODBUS item had its own 3 minute timeout and there isn't a 'global' MODBUS timeout. This means that all control registers have to be refreshed at least once every 3 minutes. Whilst this is good practice, it is no longer required for daughterboard firmware 1.103 onwards.

**From version 1.103, it is possible to 'reset' the MODBUS system completely by writing a value of 1 to coil address 999.** This will reset all coils and holding registers to the default (inactive) or local state. This will allow the burner to run from its local values in the event that some registers are holding it in an undesirable state. Note that there is a one minute timeout before the control 'forgets' the effects of the coils / holding registers and runs using its default values.

## 4.3 Coils (0XXX(X)) – WRITE TO registers (MODBUS Function Code 5)

There are 20 coil registers available in the NX6100/PPC6000 series controllers. Coils are similar to switches in that they are set on or off. The MODBUS function code 15 (write multiple coils) is not supported.

**The MODbus function code 15 (write multiple coils) is not supported.**

Once a coil is written to, this value will be current until either

- the coil register is written to again with a different value, or
- there is no MODBUS activity to or from this slave for three minutes (MODBUS time-out), or
- the power is removed from the controller, or
- the MODBUS system is reset (see 'MODBUS reset').

For daughterboard firmware levels 1.103 and greater, the coil values may also be read using MODBUS function code 1. The value read back will be the last value that was written to that coil register. This function needs to be used with care because reading from a coil register that is currently inactive (i.e. never has been written to) will activate that coil with a default value of zero. So, if after a power-up the burner is running and then coil address 7 is read (never having been written to before) a value of zero will be returned and the burner will turn off. To turn the burner back on again, a value of 1 must be written to this coil (or the MODBUS system reset / power cycled).

**Note: Not all items are valid for all models within the NX6100/PPC6000 series.**



Reg Address	Function	Details
0	Setpoint Select	0 = Run to setpoint 1 1 = Run to setpoint 2 (use for night setback etc.)
1	Release to Ignite	If used, must be 1 to allow the burner to ignite.
2	Low Fire Hold	0= Normal modulation. 1= Low Fire Hold.
3	Lead boiler Select	Choose this to be the lead boiler if boiler sequencing is in operation.
4	Mute / Reset	Due to differing approvals requirements, this function may be disabled.
5	Oxygen Trim Enable	1 = Allow trim to be ON
6	Boiler Sequencing Enable	1 = Enable boiler sequencing (lead-lag). Must be done for every unit.
7	Burner ON/OFF	If the burner is firing / able to fire, it can be held OFF by writing a zero to this register.
8 – 10	Reserved for future use.	
11	Select Profile 1	1 = Force profile 1, 0 = Run with current profile.
12	Select Profile 2	1 = Force profile 2, 0 = Run with current profile.
13	Select Profile 3	1 = Force profile 3, 0 = Run with current profile.
14	Select Profile 4	1 = Force profile 4, 0 = Run with current profile.
15 – 998	Reserved for future use.	
999	Reset MODBUS	1 = Reset all coils and holding registers to the default (inactive) state. This will allow the burner to run from its local values.

#### 4.4 Input Registers (3XXX(X)) – READ FROM (MODBUS function code 4)

There are many input registers available. The majority of these read current display or engineering (test) values from the system, but a subset of the fault log is also available if the control firmware is 1.201 or higher and the daughterboard firmware is 1.103 or higher.

For display and engineering values, these are all 16 bit registers holding signed integer numbers. When a number has decimal information, it is multiplied up to give an integer number.

For example:

173 °C Flue Temperature will read as 173

3.2% oxygen will read as 32.

17.4° servo position will read as 174.

-12% trim will read as -12.

5.00 bar setpoint will read as 500.

While the decimal precision is different for different items, it will not change for any particular item during normal use.



Each fault log item is an 8 byte structure stored in 4 consecutive 16 bit registers.

- Register 0 = (256 \* fault number) + condition.
- Register 1 = (256 \* year) + month
- Register 2 = (256 \* day) + hour
- Register 3 = (256 \* minute) + subset

Where :

- Condition = 0 for restart / reset, 1 = Cleared fault or limit (Cx), 2 = Fault (Fx) fault, 3 = Limit (Lx).
- Year is 00 to 99
- Month is 1 to 12
- Day is 1 to 31
- Hour = 0 to 23
- Minute is 0 to 59
- Subset is the fault subset information (0 to 255), if applicable.

Reg address	Function	Details
0	Drive 0 Position	As on product display.
1	Drive 1 Position	As on product display.
2	Drive 2 Position	As on product display.
3	Drive 3 Position	As on product display.
4	Drive 4 Position	As on product display.
5	Drive 5 Position	As on product display.
6	Drive 6 Position	As on product display.
7	Drive 7 Position	As on product display.
8	Drive 8 Position	As on product display.
9	Drive 9 Position	As on product display.
10	Spare	Do not use
11	Spare	Do not use
12	Measured Value	As on product display.
13	Efficiency	As on product display.
14	Inlet Temp	As on product display.
15	O2 Level	As on product display.
16	CO2 Level	As on product display.
17	Spare	
18	Hours Run	As on product display.
19	Burner Status	As on product display.
20	Trim	As on product display.
21	Setpoint	As on product display.
22	Flue Temp	As on product display.
23	Fault Number	As on product display.
24	Spare	
25	Spare	
26	Spare	
27	Profile Number	As on product display.
28	Do not use.	
29	Do not use.	
30	Modulation Rate	As on product display.
31	Spare	
32	Spare	
33	Spare	
34	Spare	



Reg address	Function	Details
35	Gas Pressure	As on product display.
36	Valve Prove Status	As on product display.
37	Flame Signal	As on product display.
38	2 <sup>nd</sup> Flame Signal	UV level if IR is used
39 to 98	Reserved for future use	
99	Daughterboard firmware version	The firmware version of the daughterboard providing modbus. 1.106 firmware will read 1106 (decimal)
100 to 999	Reserved for future use	
1000	Engineers Key 0	Device specific data
1001	Engineers Key 1	Device specific data
1002	Engineers Key 2	Device specific data
1003 to 1199	Engineers Key 3 to 199	Device specific data
2000 to 2003	Fault log item 0	Most recently logged fault event
2004 to 2007	Fault log item 1	Next recently logged fault event
2008 to 2011	Fault log item 2	Next recently logged fault event
2012 to 2015	Fault log item 3	Next recently logged fault event
2016 to 2019	Fault log item 4	Next recently logged fault event
2020 to 2023	Fault log item 5	Next recently logged fault event
2024 to 2027	Fault log item 6	Next recently logged fault event
2028 to 2031	Fault log item 7	Next recently logged fault event
2032 to 2035	Fault log item 8	Next recently logged fault event
2036 to 2039	Fault log item 9	Next recently logged fault event
2040 to 2043	Fault log item 10	Next recently logged fault event
2044 to 2047	Fault log item 11	Next recently logged fault event
2048 to 2051	Fault log item 12	Next recently logged fault event
2052 to 2055	Fault log item 13	Next recently logged fault event
2056 to 2059	Fault log item 14	Next recently logged fault event
2060 to 2063	Fault log item 15	Next recently logged fault event
2064 to 2067	Fault log item 16	Next recently logged fault event
2068 to 2071	Fault log item 17	Next recently logged fault event
2072 to 2075	Fault log item 18	Next recently logged fault event
2076 to 2079	Fault log item 19	Next recently logged fault event
2080 to 2083	Fault log item 20	Next recently logged fault event
2084 to 2087	Fault log item 21	Next recently logged fault event
2088 to 2091	Fault log item 22	Next recently logged fault event
2092 to 2095	Fault log item 23	Oldest logged fault event

#### 4.5 Holding Registers (4XXX(X)) – WRITE TO (MODBUS function code 6)

There are 20 holding (write to) registers available. These are 16 bit registers holding integer values. Writing an out of range value (for example 1000) will disable the control item and the system will go back to using its default value (immediately).

**The MODBUS function code 16 (write multiple registers) is not supported.**

Once a holding register is written to, this value will be current until either

- the holding register is written to again with a different value, or
- the holding register is written to again with an out of range value (>999), or
- there is no MODBUS activity to or from this slave for three minutes (MODBUS times out), or
- the power is removed from the controller, or
- the MODBUS system is reset (see 'MODBUS reset').

For daughterboard firmware levels 1.103 and greater, the holding register values may also be read using MODBUS function code 3. The value read back will be the last value that was written to that holding register. This function needs to be used with care because reading from a holding register that is currently inactive (i.e. has never been written to) will activate that holding with a default value of zero. So, for example, if after a power-up the burner is running with a default setpoint of 10.0 and then holding register address 0 is read (never having been written to before) a value of zero will be returned and the burners setpoint will become ZERO. To get the setpoint back to 10.0, a value of 100 (or >999) must be written to this register (or the MODBUS system reset / power cycled).

Reg. Address	Function	Details
0	Setpoint 1 Control Value	Strip decimal information – i.e. 999 = 99.9 = 9.99
1	Setpoint 2 Control Value	Strip decimal information – i.e. 999 = 99.9 = 9.99
2	Setpoint 1 Low Control Limit	Strip decimal information – i.e. 999 = 99.9 = 9.99
3	Setpoint 2 Low Control Limit	Strip decimal information – i.e. 999 = 99.9 = 9.99
4	Setpoint 1 High Control Limit	Strip decimal information – i.e. 999 = 99.9 = 9.99
5	Setpoint 2 High Control Limit	Strip decimal information – i.e. 999 = 99.9 = 9.99
6	Modulation Rate	0 = low fire, 999 = high fire
7 – 15	Reserved for future use.	



---

## 5. Specification.

---

Protocol	MODBUS RTU, 4800/9600/19200 baud, 8-bit, No parity, 1 stop bit.  MODBUS Functions supported: 1 – Read Coils 3 – Read Holding Registers 4 – Read Input Registers 5 – Write to Coils 6 – Write to Holding Registers
RS485 Interface	2-wire plus 0Vdc. Screen terminated to controller chassis. Termination resistors - 120 $\Omega$ , set by jumper link.
Isolation	50Vdc



## 6. Appendix - Communications

### 6.1 E110 Flame Monitor.

#### SETUP

Each E110 connected to the MODBUS communication bus must have a unique address. This is set using the ED510 display module. Scroll to PROGRAM SETUP, enter this sub-menu, scroll to UNIT ADDRESS, press and release the RESET key to obtain the desired address.

#### COMMUNICATIONS

The protocol to be used is MODBUS RTU. This is implemented by the master (PC, PLC, etc.) issuing a poll to the slave (Flame-Monitor) and the slave responding with the appropriate message.

A typical format of a poll request is as follows:

DST	FNC	ADR HI	ADR LO	DAT HI	DAT LO	CRC LO	CRC HI
-----	-----	-----------	-----------	-----------	-----------	-----------	-----------

DST refers to the logical address of the slave.

FNC is the function being requested. FNC 03 is a read request.

ADR is the message number or register number of the data being requested. In MODBUS, register addresses begin at 40001 but is interpreted as address 00.

DAT is the number of words being requested. A word is an integer consisting of 2 bytes.

The normal response from a slave is as follows:

DST	FNC	DBC	DATA.... Hi/Lo	CRC LO	CRC HI
-----	-----	-----	-------------------	-----------	-----------

DBC is the data byte count being returned. It must be two times the DAT number from the poll request.

DATA is the data returned and is always a series of 2 byte integers. If 4 words were requested then DBC would be 8 and there would be 8 data bytes or 4 data words containing the requested data.

**The format of the data is 4800,N,8,1 meaning 4800 baud, no parity, and 1 stop bit.**

Below is a table of currently available messages provided by the Flame-Monitor programmers, followed by a description where necessary, EP engineering code 38 or greater and EPD engineering code 4 or greater.

MODBUS MESSAGE TABLE – Holding registers (4XXX(X))

MESSAGE ADDRESS	WORD REQUESTED	RESPONSE	VALUE
00	1-6	STATUS	83 (053H) = RUN; 202 (0CAH) = LOCKOUT
01	1	MSGN	Current message being displayed (see Table 1)
02	1	GSTAT	Defines Timer Type
03	1	TIMER	Time, Flame, Address
04	1	FLAME	Flame Signal
05	1-3	LOGSTAT	Current logic module, PURGE, PTFI, AUTO (See Table 2)
06	1	INPUTS	Input limits state
07	1	OUTPUTS	Output relays state
08	2	SYSMINS	System on minutes
10	2	BNRMINS	Burner on minutes
12	2	CYCLES	Completed Burner Cycles



MESSAGE ADDRESS	WORD REQUESTED	RESPONSE	VALUE
14	1	LOCKOUT COUNT	Stored Lockout Count
15	1-6	LOCKOUT HISTORY	Last 6 Lockouts, first word is most current lockout
21	1-2	DEVTYP	Programmer device type, 5=EP, 6=EPD, 7=MicroM
22	1	AMPTYP	Amplifier Type; EUVS4=0C0H; EIR1=0A0H; ERT1, EUV1=090H;
23			
24	2	FLAME SIGNAL AVERAGES	PTFI and Auto Flame Signal Averages
35	6	Most Recent Lockout Data	Returns complete lockout description of stored lockout history. Includes lockout message, lockout module, @ burner hours, and @ burner cycles
41	6	2nd Most Recent Lockout Data	
47	6	3rd Most Recent Lockout Data	
53	6	4th Most Recent Lockout Data	
59	6	5th Most Recent Lockout Data	
65	6	6th Most Recent Lockout Data	
71	1-3	Input limits and Expansion Module registers	Returns input limits state and lower and upper expansion module (E300) registers. See Table 3
72	1-2	Expansion Module (E300) registers	Returns lower and upper Expansion Module registers
73	1		Return only upper Expansion Module register

**It is suggested that polling intervals not be less than 200 mSec per request. Requesting data such as burner minutes, system minutes and burner cycles should be kept at a minimum due to the amount of processing time required to gather that data.**

Messages 00, 05, 08, 10, 15, 21 and 26 are unique in that a limited number of successive registers can be combined with these requests. For example, a request to message 00 can contain up to 6 data words. The response to this would contain STATUS, MSGN, GSTAT, TIMER, FLAME and LOGSTAT. If the requested data word count (DAT) were to be 2 then the response would contain STATUS and MSGN only. Message 15, last 6 lockouts, can return data ranging from 1 to 6, with 1 referring to the most recent lockout.

The MSGN being transmitted is a numerical value and must be interpreted by the communicating device, which actually is an advantage since this can be made to be whatever message text the end user wants. In other words, it allows for programming custom messages without actually changing the message in the programmer. Refer to Table 1 for message information.

The Flame-Monitor stores its burner on time and system on time (L1 powered) in minutes. For display purposes, the programmer converts this to hours. The information being supplied by MODBUS will be the actual time in minutes and it is up to the communicating device to do the conversion. Since the maximum value stored in the Flame-Monitor is 9,999,999 minutes, the maximum value in hex therefore is 98967FH and comprises two data words. The maximum cycle count is 999,999 decimal or F423FH, still two data words. As an example, the System on Minutes data is transmitted from the Flame-Monitor to the interface as high word / low word as shown below:



ADDRESS 8		ADDRESS 9	
HIGH		LOW	
HIGH BYTE	LOW BYTE	HIGH BYTE	LOW BYTE
0	98H	97H	FH

**Note:** Data from address 9 cannot be accessed directly.  
All values are represented in a HEX or base 16 format.

GSTAT determines the type of value TIMER represents. TIMER can be a running timer such as is used in purge, a flame signal or meaningless. Only the lower nibble of GSTAT has any value. If this value is 0 then the TIMER value has no meaning. The value in TIMER is a background minute timer in the Flame-Monitor and should be ignored. If GSTAT is between 4 and 7, the TIMER represents the current value flame signal. If GSTAT is a 1, 2, or 3 then TIMER represents a running timer value.

The baud rate of the Flame-Monitor is fixed at 4800 bits per second. The format of the data is 8 data bits, no parity and 1 stop bit. Due to the RS485 format, the communication format is considered half- duplex. That is, only one user is permitted on the communication lines at a time.

The information contained in INPUTS and OUTPUTS represents the status of the interlocks and relays respectively. For the INPUTS, a 1 in the interlock position defines the interlock as being on or active where a 1 in any bit position in the OUTPUT register signifies the relay as being energized.

Table 3 - Refer to Fireeye bulletin E-3001 for terminal designations

**INPUTS**

Bit 7 Term P	Term 5/6	Term D		Term 8	Term 7	Term 3	bit 0 Term 13
Air Flow	Ignition	Low Fire	Ref	High Fire	Main Fuel	FVES or POC	Op Ctrl

A '1' in the opto-coupler position indicates the opto-coupler is on or interlock closed.

**EXPANSION MODULE (E300) LOWER - REFER TO BULLETIN E-3001**

Term 35	Term 34	Term 33	Term 32	Term 23	Term 22	Term 21	Term 20
Aux #6	Aux #5	Aux #4	High Temp	High Water	AUX #2	AUX #1	Op Ctrl

**EXPANSION MODULE (E300) UPPER - REFER TO BULLETIN E-3001**

Term 31	Term 30	Term 29	Term 28	Term 27	Term 26	Term 25	Term 24
High Pressure	Low Gas Pressure or Low Atomizing Media	Low Oil Temp.	Low Oil Pressure	High Gas Pressure	Oil Selected	Gas Selected	Low Water



## OUTPUTS

Term 11	Term M	Term 6		Term 5	Term 7	Term A	Term X
Auto (RA1)	Blower (RB)	Ignition (RA2)	FVES (RV)	Pilot (RP)	Main Fuel (RF)	Alarm (RL)	High Fire (RH)

LOGSTAT is an indication of what logic module the control is currently in during its operating sequence and is used for diagnostic purposes only. The message displayed corresponds to the current logic module. The range of values are 4EH for Standby, 45H for PostIdle through 4DH for Shut down 2. Note that the above values are represented in hexadecimal format.

## EXPLANATION OF LOGSTAT IN E110 STSTEMS

**Table 2:**

LOGIC DISPATCHER			
VALUE		MODULE	FUNCTION
DEC	HEX		
69	45H	MPOSTIDLE	
70	46H	MPREPURGE1	Wait for air flow and/or high fire switch to close
71	47H	MPURGE	Open Damper Purge
72	48H	MPOST PURGE	Low Fire Purge
73	49H	MTFI	Pilot Trial
74	4AH	MTFMF	Main Trial
75	4BH	MAUTO	AUTO
76	4CH	MSHTDWN1	Post Purge
77	4DH	MSHTDWN2	Post Purge
78	4EH	MIDLE	Standby

Logstat represents the current software module the Flame-Monitor is currently executing. They are named as close to the logic module the actual burner sequence is in. For instance, in the Flame-Monitor, MPURGE represents High Fire Purge where MPOSTPURGE represents the low fire start period where the mod motor is sent to the low fire position in preparation for pilot light-off. MSHUTDWN1 represents the post purge period after a complete cycle or the cool down period after a lockout.

MIDLE or STANDBY is the period of time where the operating control is open or the control is in lockout waiting for reset. On instances of false flame during the purge period, the control algorithm forces the control back to STANDBY until false flame ceases or lockout occurs.

MPREPURGE1 is the period of time prior to PURGE where the control checks the status of the air flow interlocks or the high fire proving switch (D-8). If either switch is found open, the control will remain in this state until the respective switch closes or lockout occurs.

MTFI represents the pilot trial for ignition stage of a burner sequence. MTFMF represents the main trial for main flame period where main fuel is introduced along with pilot and igniter.

MAUTO is the run period of the burner sequence.

MPOSTIDLE and MSHTDWN2 are small periods of time where certain internal tests are conducted and general cleanup before and after a cycle is performed.

The Flame-Monitor outputs the current displayed message as well as the historical lockout messages as numbers. The table that follows correlates the message number with the actual displayed test message.



**Table 1- Message Table**

DEC	HEX		TYPE AND MESSAGES
<b>E110 FLAME-MONITOR MESSAGES</b>			
1	1	R	L1-13 OPEN
2	2	H	HOLD FALSE FLAME- STANDBY
3	3	R	LOW FIRE PURGE
4	4	H	HOLD D-8 LIMIT OPEN- PURGE
5	5	H	HOLD 3-P AIR FLOW OPEN
6	6	L	LOCKOUT LINE FREQUENCY NOISE DETECTED
7	7	L	LOCKOUT FLAME FAIL - PTFI
8	8	C	CHECK UNIT ADDRESS
9	9	H	HOLD M-D LIMIT OPEN
10	A	R	IGNITION TIMING - PTFI
11	B		
12	C	R	FLAME SIGNAL - AUTO
13	D	R	CYCLE COMPLETE - POST PURGE
14	E	R	L1-13 OPEN (AFTER 2 MINUTES)
15	F	L	LOCKOUT AC POWER FAIL (EP165, EP166)
16	10	L	LOCKOUT SHORT CIRCUIT TERMINAL 5, 6 or 7
17	11	L	LOCKOUT D-8 LIMIT OPEN
18	12	L	LOCKOUT M-D LIMIT OPEN
19	13	L	LOCKOUT FLAME FAIL - MTFI
20	14	L	LOCKOUT FALSE FLAME
21	15	L	LOCKOUT 3-P INTLK OPEN (PURGE)
22	16	L	LOCKOUT 3-P INTLK CLOSED
23	17	H	HOLD 3-P INTLK CLOSED
24	18	H	HIGH FIRE PURGE
25	19	R	PLEASE WAIT (INITIALIZING)
26	1A	L	LOCKOUT 3-P INTLK OPEN -AUTO
27	1B	L	LOCKOUT 3-P INTLK OPEN (MTFI)
28	1C	L	LOCKOUT 3-P INTLK OPEN (PTFI)
29	1D	L	LOCKOUT 13-3 FVES OPEN
30	1E		
31	1F	C	CHECK FLAME SIGNAL - PTFI
32	20	C	CHECK D-8 HI LIMIT
33	21	C	CHECK M-D LOW LIMIT (CHECK)
34	22	R	FLAME SIGNAL- PTFI
35	23	C	CHECK LOW FIRE SIGNAL
36	24	R	FLAME SIGNAL - MTFI
37	25	L	LOCKOUT FLAME FAIL (AUTO)
38	26	H	HOLD 3-P INTLK OPEN - PURGE
39	27	L	LOCKOUT FUEL VALVE STATE CHANGE
<b>E300 EXPANSION MODULE LOCKOUT MESSAGES</b>			
40	28	L	3-P AIR FLOW OPEN
41	29	L	3-P HIGH WATER
42	2A	L	3-P LOW WATER
43	2B	L	3-P HIGH GAS PRESSURE
44	2C	L	3-P LOW GAS PRESSURE
45	2D	L	3-P LOW OIL PRESSURE
46	2E	L	3-P LOW OIL TEMPERATURE
47	2F	L	3-P LOW ATOMIZING MEDIA
48	30	L	3-P HIGH STEAM PRESSURE
49	31	L	3-P HIGH TEMPERATURE



DEC	HEX		TYPE AND MESSAGES
50	32	L	3-P AUX #4 OPEN
51	33	L	3-P AUX #5 OPEN
52	34	L	3-P AUX #6 OPEN
53	35	L	3-P FUEL SELECT
<b>SYSTEM DIAGNOSTIC MESSAGES</b>			
54	36	L	LOCKOUT CHECK CHASSIS
55	37	L	LOCKOUT CHECK PROGRAMMER
56	38	L	LOCKOUT CHECK AMPLIFIER
57	39	L	LOCKOUT CHECK EXPANSION MODULE
58	3A	L	LOCKOUT AMPLIFIER AUTO CHECK FAIL
59	3B	L	LOCKOUT SCANNER NOISE
76	4C	L	LOCKOUT CHECK SCANNER
<b>E300 EXPANSION MODULE HOLD MESSAGES</b>			
60	3C	H	L1-13 AUX #1 OPEN (TERMINAL 20)
61	3D	H	L1-13 AUX #2 OPEN (TERMINAL 21)
62	3E	H	L1-13 AUX #3 OPEN (TERMINAL 22)
63	3F	H	3-P HIGH WATER (TERMINAL 23)
64	40	H	3-P LOW WATER (TERMINAL 24)
65	41	H	3-P HIGH GAS PRESSURE
66	42	H	3-P LOW GAS PRESSURE
67	43	H	3-P LOW OIL PRESSURE
68	44	H	3-P LOW OIL TEMPERATURE
69	45	H	3-P LOW ATOMIZING MEDIA
70	46	H	3-P HIGH PRESSURE (TERMINAL 31)
71	47	H	3-P HIGH TEMPERATURE (TERMINAL 32)
72	48	H	3-P AUX #4 OPEN (TERMINAL 33)
73	49	H	3-P AUX #5 OPEN (TERMINAL 34)
74	4A	H	3-P AUX #6 OPEN (TERMINAL 35)
75	4B	H	3-P FUEL SELECT
<b>PURGE INTERLOCK RELATED MESSAGES</b>			
76	4C	L	LOCKOUT CHECK SCANNER
77	4D	H	HOLD D-8 LIMIT CLOSED
78	4E	L	LOCKOUT D-8 LIMIT CLOSED
79	4F	H	HOLD M-D LIMIT CLOSED
80	50	L	LOCKOUT M-D LIMIT CLOSED
81	51	L	LOCKOUT 13-3 POC CLOSED (CB ONLY)
82	52	R	DYNAMIC CHECK (CB ONLY)

**R = Run**  
**H = Hold**  
**C = Check**  
**L = Lockout**



## 6.2 YB110 BurnerLogix.

### SETUP

Each YB110 connected to the MODBUS communication bus must have a unique address. This is set using the BLV512 or BLL510 display module. Scroll to PROGRAM SETUP, enter this sub-menu, scroll to UNIT ADDRESS, press the RESET/MODIFY key, press the NEXT or BACK key to obtain the desired address, and RESET/MODIFY key to save the selection.

### COMMUNICATIONS

The protocol to be used is MODBUS RTU. This is implemented by the master (PC, PLC, etc.) issuing a poll to the slave (BurnerLogix) and the slave responding with the appropriate message.

A typical format of a poll request is as follows:

#### MESSAGE FORMAT

DST	FNC	ADR HI	ADR LO	DAT HI	DAT LO	CRC LO	CRC HI
-----	-----	-----------	-----------	-----------	-----------	-----------	-----------

DST refers to the logical address of the slave.

FNC is the function being requested. FNC 03 is a read request.

ADR is the message number or register number of the data being requested.

**For the BurnerLogix all registers are mapped as HOLDING REGISTERS, FNC 03. Register addresses begin at 40001 but is interpreted as address 00.**

DAT is the number of words being requested. A word is an integer consisting of 2 bytes. The normal response from a slave is as follows:

DST	FNC	DBC	DATA.... Hi/Lo	CRC LO	CRC HI
-----	-----	-----	-------------------	-----------	-----------

DBC is the data byte count being returned. It must be two times the DAT number from the poll request.

DATA is the data returned and is always a series of 2 byte integers. If 4 words were requested then

DBC would be 8 and there would be 8 data bytes or 4 data words containing the requested data.

**The format of the data is N,8,1 meaning no parity, and 1 stop bit. Baud rate is selectable through the keypad / display. As shipped the baud rate is 9600.**

Communication to the BurnerLogix control is made through either of the RJ-12 jacks located on the underside of the control (note figure on right). The jacks are internally wired in parallel to ease multi-dropping of BurnerLogix controls. For each of the RJ-

12 connections, the outside contacts are connected together and are designated as "A" or "+" while the inside contacts are connected together and are designated as "B" or "-". Fireeye supplies the ED512 cables in various lengths with RJ-12 plugs on each end. Refer to bulletin E-8002 for additional information.

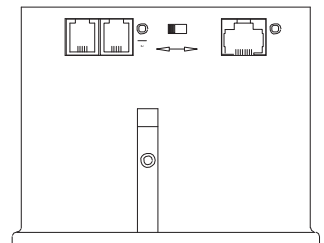



**MODBUS MESSAGE TABLE – HOLDING REGISTERS (4XXX(X))**

HOLDING REGISTER	MESSAGE ADDRESS	WORD REQUESTED	WORD RESPONSE	VALUE
40001	00	1	STATUS	83 (053H) = RUN; 202 (0CAH) = LOCKOUT
40002	01	1	MSGN	Current message being displayed (see Table 7)
40003	02	1	GSTAT	Defines Timer Type
40004	03	1	TIMER	Time in seconds
40005	04	1	FLAME	Flame Signal
40006	05	1	LOGSTAT	Current logic module, PURGE, PTFI, AUTO (see Table 6)
40007	06	1	INPUTS	Input limits state
40008	07	1	OUTPUTS	Output relays state
40009	08	2	SYSMINS	System on minutes
40011	10	2	BNRMINS	Burner on minutes
40013	12	2	CYCLES	Completed Burner Cycles
40015	14	1	LOCKOUT COUNT	Stored Lockout Count
40016	15	6	LOCKOUT IISTORY	Beginning of Last 10 Lockouts
			Most Recent Lockout data	Returns complete lockout description of stored lockout history.  Includes lockout message (1), lockout module (1), @ burner hours (2), and @ burner cycles (2)s
			2nd Most Recent Lockout Data	
			3rd Most Recent Lockout Data	
			4th Most Recent Lockout Data	
			5th Most Recent Lockout Data	
			6th Most Recent Lockout Data	
			7th Most Recent Lockout Data	
			8th Most Recent Lockout Data	
			9th Most Recent Lockout Data	
10th Most Recent Lockout Data				
40076	75	4		
-	-			
40079	78			
40080	79	11	N/A	Reserved for Fireye use
-	-			
40090	89			
<b>INTERLOCK ANNUNCIATOR</b>				
40901	900	1 - 3	YZ300 Expansion Module registers (see Table 5)	Returns lower, middle and upper interlock annunciator (YZ300) registers.
40902	901	1 - 2		Returns middle and upper interlock annunciator (YZ300) registers.
40903	902	1		Returns upper interlock annunciator (YZ300) register.

**It is suggested that polling intervals not be less than 200 mSec per request. Requesting data such as burner minutes, system minutes and burner cycles should be kept at a minimum due to the amount of processing time required to gather that data.**

The MSGN being transmitted is a numerical value and must be interpreted by the communicating device, which actually is an advantage since this can be made to be whatever message text the end user wants. In other words, it allows for programming custom messages without actually changing the message in the programmer. Refer to Table 7, for message information.



The BurnerLogix stores its burner on time (7 powered) and system on time (L1 powered) in minutes. For display purposes, the programmer converts this to hours. The information being supplied by MODBUS will be the actual time in minutes and it is up to the communicating device to do the conversion. Since the maximum value stored in the BurnerLogix is 9,999,999 minutes, the maximum value in hex therefore is 98967FH and comprises two data words. The maximum cycle count is 999,999 decimal or F423FH, still two data words.

*To convert, multiply high word by 10000H (65536), add to this high byte of low word multiplied by 100H (256) and add to this the low byte of low word. Example: (98H\*100H) + (96H\*10000H) + 7FH = 98967FH = 9,999,999 minutes.*

As an example, the System on Minutes data is transmitted from the BurnerLogix to the interface as high word / low word as shown below: The same applies to Burner On Minutes and Burner Cycles.

ADDRESS 8		ADDRESS 9	
HIGH WORD		LOW WORD	
HIGH BYTE	LOW BYTE	HIGH BYTE	LOW BYTE
0	98H	96H	7FH

All values are represented in a HEX or base 16 format.

GSTAT determines the type of value TIMER represents. TIMER can be a running timer such as is used in purge, a flame signal or meaningless. Only the lower nibble of GSTAT has any value. If this value is 0 then the TIMER value has no meaning. The value in TIMER is a background minute timer in the BurnerLogix and should be ignored. If GSTAT is between 4 and 7, the TIMER represents the current value flame signal. If GSTAT is a 1, 2, or 3 then TIMER represents a running timer value.

The format of the data is 8 data bits, no parity and 1 stop bit. Due to the RS485 format, the communication format is considered half-duplex. That is, only one user is permitted on the communication lines at a time.

The information contained in INPUTS and OUTPUTS represents the status of the interlocks and out-put relays respectively. For the INPUTS, a 1 in the interlock position defines the interlock as being on or active where a 1 in any bit position in the OUTPUT register signifies the relay as being energized.

**INPUTS (40007)**

Bit 15							Bit 8
AC Line	Term D	Term 16	Term 13	Term 21	Term 22	Term 23	Term 8
Ref	Low Fire Start	Pilot Hold	FVES POC	Start Input	Remote Reset	Spare	Purge Damper

Bit 7							Bit 0
Term P	Term 3	Term M	Term 5	Term 6	Term W	Term 7	KS
Run Interlock	Op Cntrl	Blower	Ignition	Pilot Valve	Delayed Valve	Main Valve	Safety Relay

A '1' in the opto-coupler position indicates the opto-coupler is on or interlock closed.

**OUTPUTS (4008)**

Bit 15				Bit 11			Bit 8
				Term A	Term 11	Term X	Term 12
				Alarm	Auto	High Fire	Low Fire



Bit 7				Bit 3			Bit 0
	IS	Term W	Term 7	Term M	Term 6	Term 5	
	Internal Safety	Delayed Valve	Main Valve	Blower	Pilot Valve	Ignition	

**Note:** A "1" in any bit position indicates the output or terminal is on or active.

**Table 5:**

**YZ300 LOWER (40901) – REFER TO BULLETIN YZEM-3001**

Bit 7							Bit 0
Term 47	Term 46	Term 44*	Term 43	Term 3	Term 42	Term 41	Term 40
Low Oil Temp	High Oil Temp	Low Water	High Water	Aux #3	Aux #2	Aux #1	Op Control

\* Terminals 44 and 45 are internally connected

**YZ300 MIDDLE (40902) – REFER TO BULLETIN YZEM-3001**

Bit 7							Bit 0
Term 57	Term 56	Term 55	Term 54*	Term 52	Term 51	Term 49*	Term 48
Aux #4	High Temp	High Pressure	Aux Gas	High Gas Pressure	Low Gas Pressure	Low Atomizing Media	Low Oil Pressure

\* Terminals 49 and 50 are internally connected

\* Terminals 53 and 54 are internally connected

**YZ300 UPPER (40903) – REFER TO BULLETIN YZEM-3001**

Bit 7							Bit 0
				Term P	Term 60	Term 59	Term 58
Unused	Unused	Unused	Unused	Air Flow	Aux #7	Aux #6	Aux #5

\* Unused Bits 4-7 will always return 0



## EXPLANATION OF LOGSTAT IN YB110 SYSTEMS

**Table 6:**

LOGSTAT is an indication of what logic module the control is currently operating in during its cycle and is used for diagnostic purposes only. If a lockout occurs the current value of LOGSTAT is stored as part of the lockout information. The message displayed corresponds to the current logic module.

LOGIC DISPATCHER			
VALUE		MODULE	FUNCTION
DEC	HEX		
1	01H	STANDBY	Idle state
2	02H	BLOWER ON	1/2 second period after operating control closes when blower motor is energized
3	03H	PURGE	Open Damper Purge or waiting for air flow and/or high fire switch to close
4	04H	PURGE	Low Fire Purge
5	05H	PTFI	Pilot Trial for Ignition
6	06H	PTFI	Pilot Trial for Ignition for YP3XX programmers
7	07H	PTFI	If PTFI is greater than 5 seconds and early spark termination is not needed
8	08H	PTFI	If PTFI is greater than 5 seconds and early spark termination is needed
9	09H	PILOT	Pilot Hold, YP138 only
10	0AH	MTFI	Main Trial for Ignition
11	0BH	MTFI	Main Trial for Ignition with terminal 5 de-energized
12	0CH	AUTO	Delayed valve on
13	0DH	AUTO	AUTO
14	0EH	AUTO	On YP138 programmer, hold for 20 seconds with terminals 6 and 7 energized
15	0FH	AUTO	On YP138 programmer, when terminal 21 first energized, wait for M-D to close
16	10H	POSTPURGE	Post Purge
17	11H	POSTPURGE	Post Purge period if flame fail lockout
18	12H	POSTPURGE	Idle state if unit is in lockout

Logstat represents the current software module the BurnerLogix is currently executing.

The BurnerLogix outputs the current displayed message as well as the historical lockout messages as numbers. The table below correlates the message number with the actual displayed text message.



**Table 7:**

DEC	HEX		BURNERLOGIX MESSAGES
1	1	H	T16 M-D LIMIT OPEN - AUTO
2	2	H	HOLD FALSE FLAME- STANDBY
3	3	R	LOW FIRE PURGE
4	4	H	HOLD M-8 LIMIT OPEN- PURGE
5	5	H	See Interlock Annunciation Message Table
6	6	H	T16 M-D LOW LIMIT - AUTO
7	7	L	LOCKOUT FLAME FAIL - PTFI
8	8	H	T16 INPUT CLOSED
9	9	H	HOLD M-D LIMIT OPEN
10	A	R	IGNITION TIMING - PTFI
11	B	C	CHECK FLAME SIGNAL - MTFI
12	C	R	FLAME SIGNAL - AUTO
13	D	R	CYCLE COMPLETE - POST PURGE
14	E	R	L1-3 OPEN
15	F	H	T21 INPUT CLOSED
16	10	L	LOCKOUT M-D LIMIT OPEN - PTFI
17	11	L	LOCKOUT M-8 LIMIT OPEN
18	12	L	LOCKOUT M-D LIMIT OPEN
19	13	L	LOCKOUT FLAME FAIL - MTFI
20	14	L	LOCKOUT FALSE FLAME
21	15	L	LOCKOUT 3-P INTLK OPEN (PURGE)
22	16	L	LOCKOUT 3-P INTLK CLOSED
23	17	H	HOLD 3-P INTLK CLOSED - STANDBY
24	18	H	HIGH FIRE PURGE
25	19	L	LOCKOUT M-D LIMIT OPEN - MTFI
26	1A	L	LOCKOUT 3-P INTLK OPEN -AUTO
27	1B	L	LOCKOUT 3-P INTLK OPEN - MTFI
28	1C	L	LOCKOUT 3-P INTLK OPEN - PTFI
29	1D	L	LOCKOUT T13 FVES OPEN
30	1E	L	LOCKOUT 3-P INTLK OPEN - PREPURGE
31	1F	C	CHECK FLAME SIGNAL - PTFI
32	20	C	CHECK M-8 HI LIMIT (HI FIRE PURGE)
33	21	C	CHECK M-D LOW LIMIT (LO FIRE START)
34	22	R	FLAME SIGNAL- PTFI
35	23	C-H	HOLD T21 or CHECK LOW FIRE SIGNAL - AUTO
36	24	R	FLAME SIGNAL - MTFI
37	25	L	LOCKOUT FLAME FAIL (AUTO)
38	26	H	HOLD 3-P INTLK OPEN - PREPURGE
39	27	L	LOCKOUT FUEL VALVE STATE CHANGE
104	68	R	LEARNING FLAME (PTFI and AUTO)
<b>SYSTEM DIAGNOSTIC MESSAGES</b>			
54	36	L	LOCKOUT CHECK CHASSIS
55	37	L	LOCKOUT CHECK PROGRAMMER



DEC	HEX		BURNERLOGIX MESSAGES
56	38	L	See Interlock Annunciation Message Table
57	39	L	LOCKOUT CHECK EXPANSION MODULE
58	3A	L	LOCKOUT CHECK WIRING
59	3B	L	LOCKOUT CHECK FUSE
76	4C	L	LOCKOUT CHECK SCANNER
<b>PURGE INTERLOCK RELATED MESSAGES</b>			
77	4D	H	HOLD M-8 LIMIT CLOSED
78	4E	L	LOCKOUT M-8 LIMIT CLOSED
79	4F	H	HOLD M-D LIMIT CLOSED
80	50	L	LOCKOUT M-D LIMIT CLOSED
81	51		Reserved for future use
82	52		Reserved for future use
83	53	L	LOCKOUT FLAME FAIL - PILOT
84	54	L	LOCKOUT 3-P INTLK OPEN - PILOT
85	55	L	LOCKOUT M-D LIMIT OPEN - PILOT
86	56	L	LOCKOUT T13 FVES OPEN - PILOT
87	57	L	LOCKOUT T13 FVES OPEN - POST PURGE

**Table 8:**

INTERLOCK ANNUNCIATOR				
DEC	HEX	STATE	TERMINAL	YZ300 INTERLOCK ANNUNCIATOR LOCKOUT MESSAGES
41	29	L	3-43	HIGH WATER
42	2A	L	43-44	LOW WATER
43	2B	L	51-52	HIGH GAS PRESSURE
44	2C	L	50-51	LOW GAS PRESSURE
92	5C	L	52-54	AUX GAS
45	2D	L	47-48	LOW OIL PRESSURE
56	38	L	44-46	HIGH OIL TEMPERATURE
46	2E	L	46-47	LOW OIL TEMPERATURE
47	2F	L	48-50	LOW ATOMIZING MEDIA
48	30	L	54-55	HIGH PRESSURE
49	31	L	55-56	HIGH TEMPERATURE
50	32	L	56-57	AUX #4 OPEN
51	33	L	57-58	AUX #5 OPEN
52	34	L	58-59	AUX #6 OPEN
53	35	L	59-60	AUX #7 OPEN
40	28	L	60-P	AIR FLOW OPEN



INTERLOCK ANNUNCIATOR				
DEC	HEX	STATE	TERMINAL	YZ300 INTERLOCK ANNUNCIATOR HOLD MESSAGES
94	5E	H	L1-40	OP CONTROL OPEN
60	3C	H	40-41	L1-3 AUX #1 OPEN
61	3D	H	41-42	L1-3 AUX #2 OPEN
62	3E	H	42-3	L1-3 AUX #3 OPEN
63	3F	H-C	3-43	HIGH WATER
64	40	H-C	43-44	LOW WATER
65	41	H-C	51-52	HIGH GAS PRESSURE
66	42	H-C	50-51	LOW GAS PRESSURE
95	5F	H-C	52-54	AUX GAS
67	43	H-C	47-48	LOW OIL PRESSURE
96	60	H-C	44-46	HIGH OIL TEMPERATURE
68	44	H-C	46-47	LOW OIL TEMPERATURE
69	45	H-C	48-50	LOW ATOMIZING MEDIA
70	46	H-C	54-55	HIGH PRESSURE
71	47	H-C	55-56	HIGH TEMPERATURE
72	48	H-C	56-57	AUX #4 OPEN
73	49	H-C	57-58	AUX #5 OPEN
74	4A	H-C	58-58	AUX #6 OPEN
75	4B	H-C	59-60	AUX #7 OPEN
5	5	H-C	60-P	AIR FLOW OPEN

**R = RUN    H = HOLD    L = LOCKOUT    C = CHECK**



---

## NOTICE

When Fireeye products are combined with equipment manufactured by other and/or integrated into systems designed or manufactured by others, the Fireeye warranty, as stated in its General Terms and Conditions of Sale, pertains only to the Fireeye products and not to any other equipment or to the combined system or its overall performance.

---

## WARRANTIES

FIREYE guarantees for *one year from the date of installation or 18 months from date of manufacture* of its products to replace, or, at its option, to repair any product or part thereof (except lamps and photocells) which is found defective in material or workmanship or which otherwise fails to conform to the description of the product on the face of its sales order. **THE FOREGOING IS IN LIEU OF ALL OTHER WARRANTIES AND FIREYE MAKES NO WARRANTY OF MERCHANTABILITY OR ANY OTHER WARRANTY, EXPRESS OR IMPLIED.** Except as specifically stated in these general terms and conditions of sale, remedies with respect to any product or part number manufactured or sold by Fireeye shall be limited exclusively to the right to replacement or repair as above provided. In no event shall Fireeye be liable for consequential or special damages of any nature that may arise in connection with such product or part.



A UTC Fire & Security Company

FIREYE  
3 Manchester Road  
Derry, New Hampshire 03038 USA  
[www.fireeye.com](http://www.fireeye.com)

MOD-1001  
MARCH 15, 2010