



# MBCE-230FR Flame Sensor Module



## DESCRIPTION

The MBCE-230FR modules provide visual indication and electrical outputs that signal the user regarding flame presence in a combustion chamber. The module uses Fireye flame rods to sense flame presence independently or as components in a burner management system. Many operational characteristics are provided including:

- CE approved
- Self-contained: 230 VAC, 50/60 Hz operation
- Flame Rod compatible
- Flame ON/OFF LED indicator
- 4-20mA permits direct reading of flame signal strength
- Uses CE approved 11-pin relay base
- Panel surface or DIN-rail mounting
- Self-check

The unit provides a cost effective, self-checking method of monitoring flames using the ionization principle.

Check with Fireye for more details by contacting your local distributor or by checking the Fireye home page at [www.fireye.com](http://www.fireye.com).

**NOTE:** When the MBCE-230FR modules are used, additional means must be furnished to provide those functions usually provided by flame safeguard control systems to meet local regulations (i.e.: safe start check, valve closure, starting and running interlocks, safety timings, etc.).



**NOTICE:** When Fireye products are combined with equipment manufactured by others and/or integrated into systems designed or manufactured by others, the Fireye warranty, as stated in its General Terms and Conditions of Sale, pertains only to the Fireye products and not to any other equipment or to the combined system or its overall performance.



## ORDERING INFORMATION

PART NUMBER	DESCRIPTION	BULLETIN
<b>Flame Sensor</b>		
MBCE-230FR-1	Single channel module, 230 VAC 50/60 Hz, use with flame rod, 1 sec. FFRT.	MBCE-1001
MBCE-230FR-3	Single channel module, 230 VAC 50/60 Hz, use with flame rod, 3 sec. FFRT.	MBCE-1001
<b>Wiring Base</b>		
60-2886	Plug in wiring base, DIN rail or panel surface mount complete with retaining kit.	MBCE-1001
<b>Mounting Rails</b>		
60-2539-12	DIN style mounting rail, 12 inches, mounts up to 4 modules.	
60-2539-24	DIN style mounting rail, 24 inches, mounts up to 8 modules.	
60-2539-36	DIN style mounting rail, 36 inches, mounts up to 12 modules.	
<b>Flame Rods</b>		
69ND1-1000K4	Flame rod 1/2" NPT mount, 12" length.	SC-103
69ND1-1000K6	Flame rod 1/2" NPT mount, 18" length.	SC-103
69ND1-1000K8	Flame rod 1/2" NPT mount, 21" length.	SC-103

## PRODUCT SPECIFICATIONS

<b>Supply Voltage:</b>	MBCE-230FR - 230 VAC (+10%, -15%), 50/60 Hz (@ 0.1 Amp consumption)
<b>Flame Relay Output:</b>	SPDT 1 Amp Resistive @ 250VAC, 1 Amp @ 30VDC
<b>Flame Fail Response Time:</b>	1 or 3 seconds - depending on part number (-1, -3)
<b>Operating Temperature:</b>	- 40° F to 150° F (- 40° C to 65° C)
<b>Storage Temperature:</b>	- 40° F to 176° F (- 40° C to 80° C)
<b>Humidity:</b>	85% RH (max), non-condensing.
<b>Agency Approvals:</b>	
<b>MBCE-230FR</b>	CE / EN298 / EN230
<b>Shipping Weight:</b>	1 lb (.5 Kg)
<b>Flame Rod:</b>	S1 = Terminal 4 S2 = Terminal 8 (local panel ground)
<b>Power:</b>	Terminals 4 and 8, - 240 - 360 VAC <i>Note:</i> Measured with digital VOM Terminals 5 and 8 are internally connected.
<b>Sensitivity:</b>	Flame Rod - 3 $\mu$ A @ 100 Meg ohms
<b>IP-Rating</b>	IP-20

**FIGURE 1. DIMENSIONS OF DIN RAILS, WIRING BASES AND FLAME SWITCH MODULES SHOWN IN INCHES (MM)**

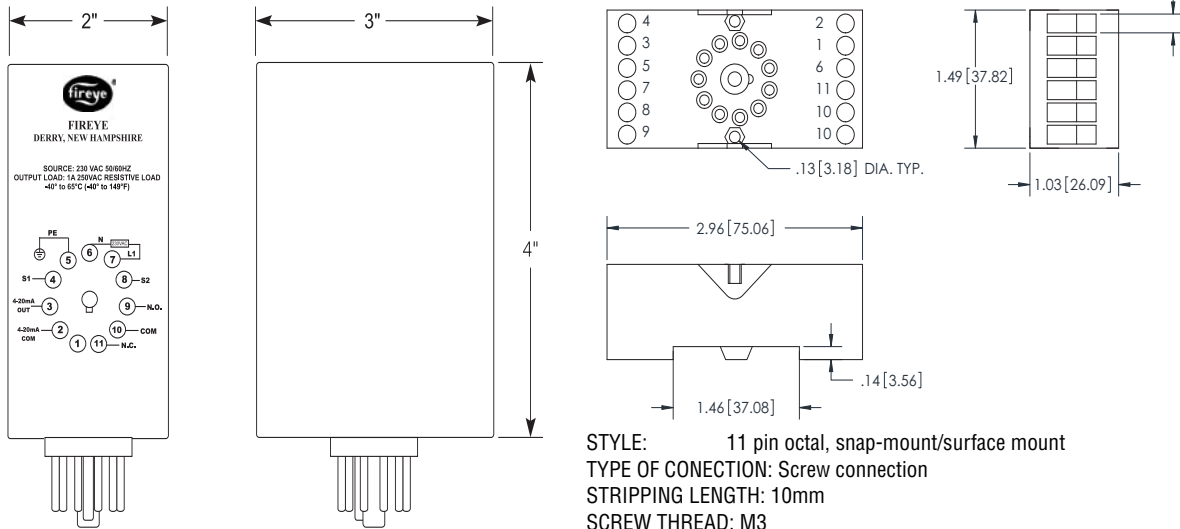

STYLE: 11 pin octal, snap-mount/surface mount  
 TYPE OF CONNECTION: Screw connection  
 STRIPPING LENGTH: 10mm  
 SCREW THREAD: M3  
 WIRE SIZE: Maximum up to 2 - #14AWG each terminal  
 ELECTRICAL RATING: 400V, 10A  
 To secure MBCE-230FR to socket use retaining kit P/N 60-2886

DIN RAIL MOUNT		PART NO.	LENGTH
		60-2539-12	L = 12" (305)
		60-2539-24	L = 24" (610)
		60-2539-36	L = 36" (914)

**SENSOR INSTALLATION**

**WARNING: Incorrect flame rod installation may result in the generation of a false flame signal, causing unburned fuel to collect in the combustion chamber. The result can be explosions, injuries and property damage. Be certain that the flame rod detects only pilot and/or main flames.**

Route sensor wiring a sufficient distance from ignition and other high voltage or high current wiring to avoid electrical interference. Interference from ground currents, nearby conductors, radio-frequency emitters (wireless devices), and inverter drives can induce false flame signals. Shielded cables can help reduce interference with the shield connected to ground at the control end only. The wire type and its capacitance (picofarads or microfarads) to ground may cause low signal problems, so a grounded shield may decrease the signal due to the cable's internal capacitance. Multiple sensor leads run together without shielding may interfere or "cross talk", so the shield or flexible armor must be grounded to prevent this situation. For flame rod sensor runs approximately 100 feet (30 meters) or greater, use Belden P/N 8254-RG62 coax cable. To achieve the maximum wiring distance, the shield should not be grounded (keep in mind that an underground shield provides less protection against electrical interference). Depending on field connections, sensor wiring can be up to 200 feet (61 meters).

**Do not ground the shield to terminal GND.**

*Unshielded sensor wiring must not be run in common with other wires; it must be run in separate conduit. Multiple flame sensor wiring must not be run together in a common conduit or wireway. Use #14 to #18 AWG wire suitable for 90°C (194°F) and 600 volt insulation, and run each pair of leads in its own shielded cable. Multiple shielded cables can be run in a common conduit.*

Flame rods are recommended to be used on gas burners. They accumulate soot on oil burners, causing nuisance shutdowns and unsafe operating conditions.

See the burner manufacturer's literature for flame rod mounting location.



## INDICATION LEDS

The CE Flameswitch contains two bi-color LEDs that are used to provide flame status and alarm condition per the following table.

LEDs can be viewed through the cutout located on the top side of the unit.

LED	COLOR	DEVICE STATUS
LED 1 (SYSTEM LED)	GREEN	SYSTEM OK
	BLINKING GREEN	SELF-CHECKING
	BLINKING RED/ORANGE	ALARM
	SOLID RED/ORANGE	SYSTEM FAULT
LED 2 (FLAME LED)	SOLID GREEN	GOOD FLAME
	BLINKING GREEN	WEAK FLAME
	BLINKING RED/ORANGE	FLAME RELAY FAULT
	SOLID RED/ORANGE	OTHER FLAME FAULTS
	OFF	FLAME OFF

## WIRING BASE PINOUT INFORMATION

The following table shows the wiring information and the ratings. To guarantee proper operation, the unit **MUST NOT** be operated above its maximum rating.

TERMINAL NO.	TERMINAL NAME	DESCRIPTION	DIRECTION	RATING
1	(11)	OPEN	UNUSED	N/A
2	(A1)	4-20mA COM	4-20mA COMMON	LOCAL GROUND
3	(14)	4-20mA OUT	4-20mA OUTPUT	OUTPUT 28 VDC, 20mA max
4	(12)	S1	FLAME ROD EXCIATION	OUTPUT 300 VDC, 1mA max
5	(22)	PE	PROTECTIVE EARTH	EARTH GROUND
6	(21)	L2	NEUTRAL	INPUT
7	(24)	L1	LINE VOLTAGE SUPPLY	INPUT 230 VAC (+10%, -15%) 50/60 Hz
8	(32)	S2	FLAME ROD RETURN	EARTH GROUND
9	(34)	NO	FLAME RELAY NORMALLY OPEN (N.O.)	OUTPUT 230 VAC, 1A max 30 VDC, 1A max
10	(A2)	COM	FLAME RELAY COMMON	INPUT 230 VAC, 1A max 30 VDC, 1A max
11	(31)	NC	FLAME RELAY NORMALLY CLOSED (N.C.)	OUTPUT 230 VAC, 1A max 30 VDC, 1A max

Any equipment connected to the 4-20 mA current loops shall be insulated from hazardous live parts by protective separation (e.g. double or reinforced insulation according to DIN EN 61010, DIN EN 50178, DIN EN 60730-1 or DIN EN 60950).

### FLAME SIGNAL STRENGTH vs. 4-20mA OUTPUT

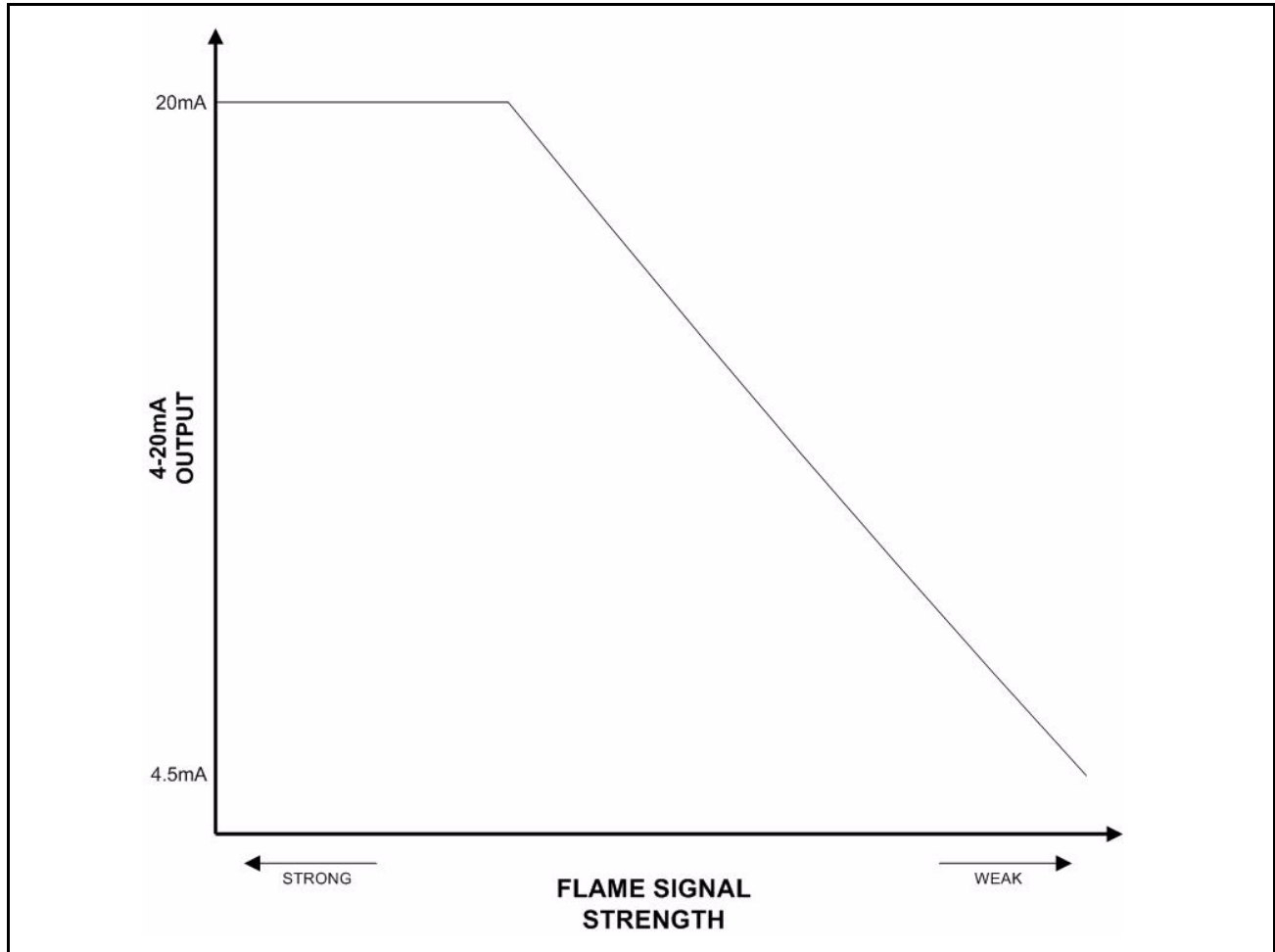

4-20mA measurements can be taken from the test jack connector located at the faceplate of the unit. Measurements can also be taken using the dedicated 4-20mA OUT & 4-20mA COM terminals located at the wiring base.

**NOTE:** The 4-20mA return path is labeled “GND” on the faceplate. This is simply a local return path for the 4-20mA current and it **MUST NOT** be attached or referenced to earth ground or other forms of ground connection. Likewise, 4-20mA COM is the return path at the wiring base and **MUST NOT** be attached or referenced to earth ground or other forms of ground connection.

**FIGURE 2. TYPICAL APPLICATION - MBCE-230FR**

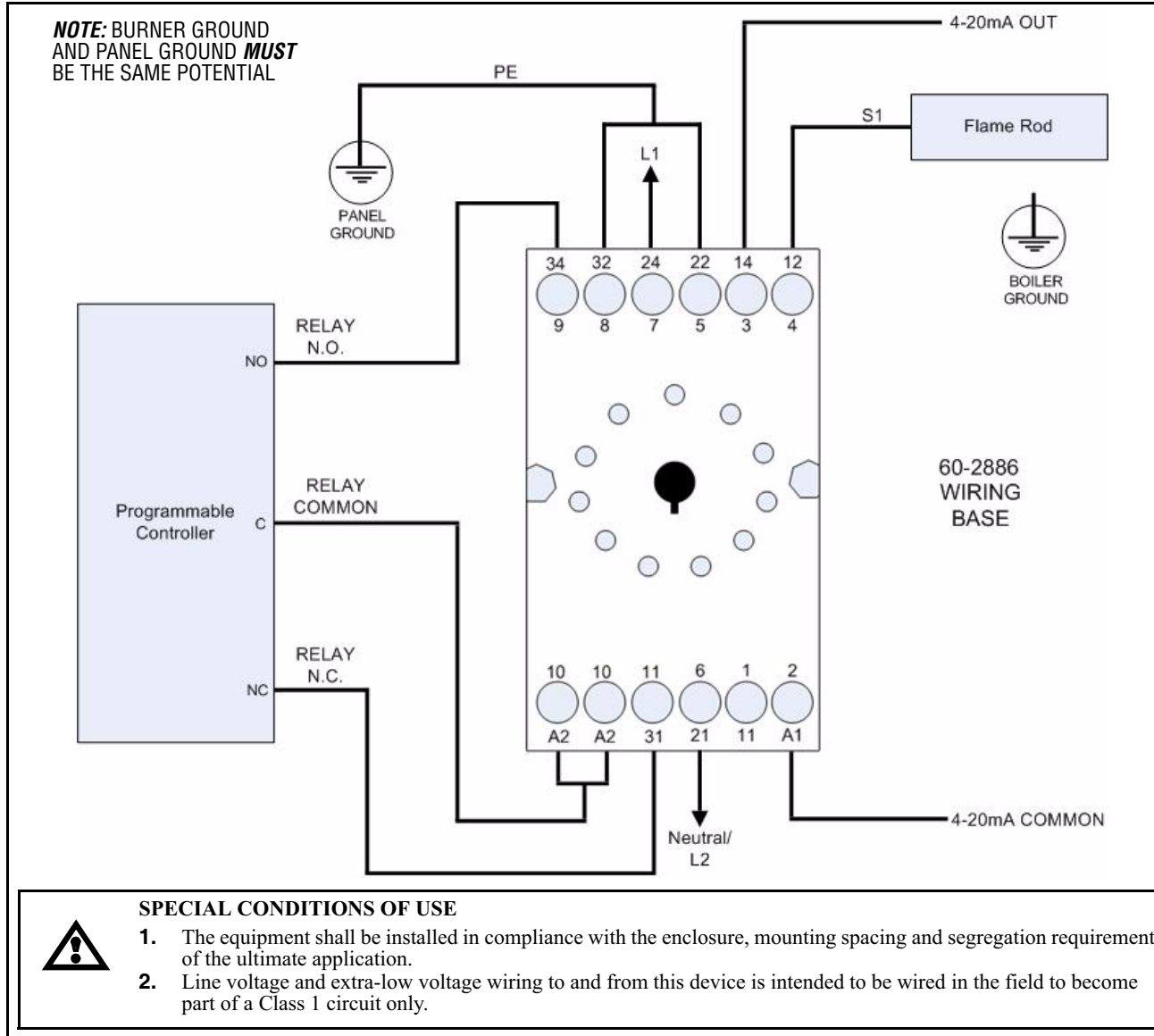

**NOTICE**

When Fireye products are combined with equipment manufactured by others and/or integrated into systems designed or manufactured by others, the Fireye warranty, as stated in its General Terms and Conditions of Sale, pertains only to the Fireye products and not to any other equipment or to the combined system or its overall performance.

**WARRANTIES**

FIREYE guarantees for *one year from the date of installation or 18 months from date of manufacture* of its products to replace, or, at its option, to repair any product or part thereof (except lamps, electronic tubes and photocells) which is found defective in material or workmanship or which otherwise fails to conform to the description of the product on the face of its sales order. **THE FOREGOING IS IN LIEU OF ALL OTHER WARRANTIES AND FIREYE MAKES NO WARRANTY OF MERCHANTABILITY OR ANY OTHER WARRANTY, EXPRESS OR IMPLIED.** Except as specifically stated in these general terms and conditions of sale, remedies with respect to any product or part number manufactured or sold by Fireye shall be limited exclusively to the right to replacement or repair as above provided. In no event shall Fireye be liable for consequential or special damages of any nature that may arise in connection with such product or part.



FIREYE  
 3 Manchester Road  
 Derry, New Hampshire 03038 USA  
 www.fireye.com

MBCE-1001  
 FEBRUARY 13, 2009  
 Supersedes Sept. 16, 2008