

Fireye® Primeline School

In 2009 Fireye will offer two professional training classes for burner/boiler service and engineering personnel.

These classes use pertinent case histories and step-by-step instruction for servicing the complete line of Fireye controls. Our skilled instructors have many years of experience in the boiler industry and are experts on the various flame safeguard control systems.

For additional Fireye Product Training Schools, we recommend contacting your local Fireye Field Office or Fireye Primeline Distributor for dates and programs of schools specific to your application needs.

Fireye training classes are also listed on www.fireye.com. Click on “*Training Schools*” for more information.

Primeline Training Dates

- **May 5, 6, 7**
(Tues, Wed, Thurs)
- **September 15, 16, 17**
(Tues, Wed, Thurs)

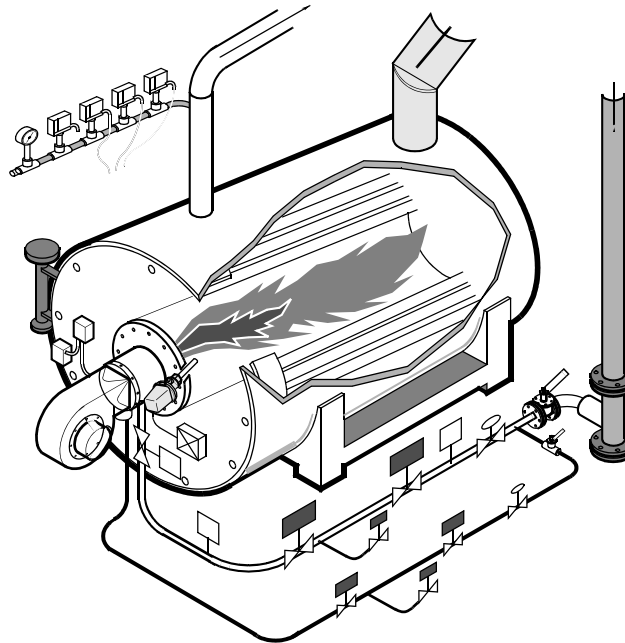

Course Outline

- Codes and Regulations
 - Explosion Hazards
 - Safe Operating Sequence
 - Basic Flame Safeguard
 - Types of Flame Detectors
 - Circuit Programming
 - Practical Service Procedures
 - Introduction to Servicing
 - Hands-on Wiring
 - Sequence of Operation
 - Fireye Product Lines
- All products covered including:
- Flame-Monitor™
 - MicroM and M-Series Products
 - BurnerLogix
 - Simplicity Scanner
 - D-Series
 - E340 Boiler Control
 - Nexus (Overview)
- Plant Tour

General Information

REGISTRATION

Early registration is essential as classes are limited to 25 persons. Application forms are available and should be submitted at least one month in advance of the starting date of the desired school session. A maximum of two people from one company per class will be accepted. Contact Fireye directly to confirm additional attendees. Confirmations will be mailed from Fireye three weeks prior to the start of the class selected. Please notify Fireye of any substitutions.

MEALS: Lunches and Class Banquet on Wednesday evening all are furnished by Fireye.

COURSE LOCATION: The course will be held in our Derry, NH plant. Directions will be mailed with your confirmation.

ROOMS: Hotel reservations and costs are the responsibility of the student. Hotel and transportation information will be mailed with your confirmation.

SHIRTS: A polo style shirt, embroidered with the Fireye logo, will be provided to each student. Please specify shirt size.

COURSE HOURS:

Tuesday 9:00AM - 5:00PM.
Wednesday 8:30AM - 5:00PM
Thursday 8:30AM - 2:00PM

CERTIFICATE: Fireye awards each student a certificate recognizing course completion at the end of the course.

CHARGES: A non-refundable \$245.00 tuition charge is made for the Fireye Training School.

Authorized Fireye Distributors may pay with a Purchase Order. All others must pay with check. This fee is due with application.

All applications are confirmed by Fireye, Derry, NH.

Enrollment Form

Please type or print clearly

Name _____

Position _____

Company _____

Telephone _____

Fax _____

E-mail _____

Address _____

City _____ State _____ Zip _____

US Citizen: Yes _____ No _____ (please check one)

If No, country of citizenship _____

Shirt size (please circle) M L XL XXL

Class dates _____

Signature _____

Date _____

PO # _____
(Distributors only)

Check # _____

Credit Card # _____

(VISA or M/C only) Exp. _____

Tuition (\$245.00) is due with application.

All applications are confirmed by Fireye.

MAIL, EMAIL or FAX to:

Fireye Primeline Training School
3 Manchester Rd.
Derry, NH 03038 USA
Tel: 603-432-4100 • Fax: 603-432-1570
michelle.berman@fireye.com



A UTC Fire & Security Company

2009 PRIMELINE Training School



For Burner/Boiler Service Personnel and Engineers