



D-4041
MAY 10, 2011



SOLID STATE Burner Management Controls SERIES D40-41



UV90



45UV5



UV8A



45UV3-1050



UV1A



69ND1



48PT2

DESCRIPTION

FIREYE® Series D40-41 Burner Management Controls provide ignition and flame failure protection for manually started oil or gas burners. Plug-in Amplifier Modules permit the selection of ultra-violet, repetitive self-check ultra-violet, AUTOCHECK infrared, or rectification methods of flame detection. The control system includes a safe start check, effective on each start. If flame signal (real or simulated) is detected, the unit cannot be started. For increased safety and reliability, Fireye 72D1R3 AUTOCHECK infrared amplifier (using the pulsing flame signal) and 72DUVS ultraviolet amplifier (using a scanner shutter) check the function of the flame detecting system for component failure during each burner firing cycle. Meter test jacks on each amplifier module provide flame signal readout with a DC voltmeter. Flame failure response time is four seconds (max.). When amplifier modules with T suffix are used, the flame failure response time is reduced to one second (max.).

The control provides three SPDT and one SPNO load switches for external loads and starting circuits. Fireye D40-41 Burner Management controls may be adapted to a simple control system or as a building block with auxiliary devices to provide additional functions.

SPECIFICATIONS

Supply Voltage:

D40-120V (Min. 102V: Max. 132V) 50/60 Hz.

D41-230V (Min. 196V: Max. 253V) 50/60 Hz.

Power Consumption (Operating): 20 VA.

Maximum Simultaneous Connected Load: 2000 VA.

Ambient limits:

	Max.	Min.
Control-Amplifier	140° F (60° C)	- 40° F (-40° C)
UV1A-UV2-UV8A-UV90 Scanner	200° F (93° C)	- 40° F (-40° C)
45UV5 Scanner	200° F (93° C)	- 40° F (-40° C)
48PT2 Scanner	140° F (60° C)	- 40° F (-40° C)
69ND1 Flame Rod (Tip 2460° F)	1500° F (816° C)	- 40° F (-40° C)



MODEL CHANGE NOTICE

All 70D40/41 models produced before May 1986 have terminal load ratings as shown in box A below. Beginning with May 1986 production, 70D40/41 models bear the CODE 2 (or higher) Label and have the terminal ratings shown in box B below.

A. Code 1 terminal load ratings all models:		B. Terminal Load ratings for 70D40 Code 2 Models:				
Max. Rating of each external load terminal:		TERMINAL	MAXIMUM RATINGS			
		3, 5, 6, 8, X, A	125 VA PILOT DUTY			
120 VAC	230 VAC	7 Code 2 or higher models only	250 VA Pilot Duty or Motor rating as given below:			TERMINAL 7 ONLY: Alternate Rating — 300 VA transformer and 130 VA pilot duty; and maximum combined load of not more than 3 motorized valves — Holding — 180 VA Opening — 635 VA Locked Rotor — 730 VA
5 amps	2.5 amps		Voltage	120 VAC	230 VAC	
125 VA	125 VA		FULL LOAD	9.8 A	5.1 A	
Pilot Duty	Pilot Duty		LOCKED ROTOR	58.8	30.6 A	
C. CE Load ratings for 70D41						
		TERMINAL	MAXIMUM RATING AT 253 VAC			
		3, 5, 6, 8, 13, D	1A RESISTIVE OR ($\cos \phi = 1$)			
		7, A, M, P, X	4.5A RESISTIVE OR ($\cos \phi = 1$)			

ORDERING INFORMATION

Each complete Fireeye Series D40-41 system includes:

1. A Control chassis and cover.
2. A plug-in amplifier.
3. A flame Scanner.
4. A Wiring Base

To specify a surface mounted control system for 120 volts 50/60 Hz. with Infrared (AUTOCHECK) flame detection, with four second flame failure response timings, surface mounted, select the following:

- 70D40 Control and Cover
- 72D1R1 Plug-in amplifier
- 48PT2 Flame Scanner (specify cable length and mount)
- 60-1386-2 Wiring Base

Fireeye D40-41 controls supersede similar Fireeye C-Series controls and are directly plug-in replaceable. The following chart illustrates the comparison.

	D SERIES	C SERIES
OBSOLETE PART NUMBER	COMPONENTS	
D40-5030	Control 70D40 - Amplifier 72D1R1	Type 26DF4 - Model 5030
D41-5131	Control 70D41 - Amplifier 72D1R1T	Type 26DF4 - Model 5131
D40-5060	Control 70D40 - Amplifier 72DUV1	Type 25DU4 - Model 5060
D41-5161	Control 70D41 - Amplifier 72DUV1T	Type 25DU4 - Model 5161
D40-5050	Control 70D40 - Amplifier 72DRT1	—
D41-5151	Control 70D41 - Amplifier 72DRT1T	—

Control 70D40 with Amplifier 72DUV1 will also replace a Fireeye Type 25DU4 model 5040 provided the wiring is changed to the appropriate wiring shown later in this document.

Note: When a C-Series unit is replaced with a D-Series unit, the chassis retaining clip (for a quarter turn fastener) in the wiring base must be replaced with a threaded clip that is supplied with each D-Series Control.



DESCRIPTION OF FIREYE SERIES D40-41 COMPONENTS

Control Chassis and Cover	Amplifier	Flame Scanner
Use with 70D40 (120VAC) 50-60 Hz or 70D41 (230VAC) 50/60 Hz	Rectification 72DRT1 2-4 sec. FFRT 72DRT1T 1 sec. FFRT	69ND1-1000K4 1/2" mount 12" (300mm) flame rod. 69ND1-1000K6 1/2" mount 18" (450mm) flame rod. 69ND1-1000K8 1/2" mount 24" (600mm) flame rod.
	Infrared (IR) "Autocheck" 72D1R1 2-4 sec. FFRT 72D1R1T 1 sec. FFRT *72D1R3 2-4 Sec. FFRT *72D1R3T 1 Sec. FFRT * For specific applications see note below.	48PT2-1003 1/2" straight mount 96" (2400mm) cable. 48PT2-9003 1/2" angle mount 96" (2400mm) cable. 48PT2-1007 1/2" straight mount 48" (1200mm) cable. 48PT2-9007 1/2" angle mount 48" (1200mm) cable.
	Ultraviolet (UV) 72DUV1 2-4 sec. FFRT 72DUV1T 1 sec. FFRT	UV8A 1/2" angle mount 72" (1800mm) wire (no cable). UV1A3 1/2" straight mount 36" (900mm) cable. UV1A6 1/2" straight mount 72" (1800mm) cable. UV2 3/8" straight mount 36" (900mm) cable. UV90-3, -6, -9 90° side opening, 36" (900mm), 72" (1800mm), or 108" (2700mm) cable. 45UV3-1050 3/4" straight mount cast aluminum housing, 72" (1800mm) wire (no cable).
70D40 Only	72DUVS4 Repetitive Self-Check 2-4 sec. FFRT 72DUVS1T Repetitive Self-Check 1 sec. FFRT	45UV5-1009 1" NPT mount 72" (1800mm) wire (no cable), 120VAC shutter. or 45UV5-1008 1" BSP mount 72" (1800mm) wire (no cable), 120VAC shutter.
70D40M Only	Infrared (IR) AUTOCHECK 72D1R3TM 1 sec. FFRT For special applications see Note below.	48PT2-1003 1/2" straight mount 96" (2400mm) cable. 48PT2-9003 1/2" angle mount 96" (2400mm) cable. 48PT2-1007 1/2" straight mount 48" (1200mm) cable. 48PT2-9007 1/2" angle mount 48" (1200mm) cable.
70D41 Only	72DUVS1T or 72DUVS4	45UV5-1007 1" BSP mount 72" (1800mm) wire, no cable. 230VAC shutter
Wiring Base	60-1386-2 Standard base for surface mounting 60-1466-2 Open base for cabinet mounting	

NOTE: Infrared "AUTOCHECK" amplifier modules 72D1R3, 72D1R3T, and 72D1R3T may be used for burner applications firing special fuel such as sawdust, sander dust, low BTU gas. The 72D1R3 type amplifiers are not to be used on any liquid fuel fired burner as it may result in malfunction causing damage to property and/or injury to personnel.

ACCESSORIES / SPARE PARTS					
Part No.	Description	Used with	Part No.	Description	Used with
4-263-1	Firetron Cell	48PT2	60-801	1/2" Coupling w/Pyrex Window	48PT2
4-314-1	UV Tube	45UV5, 45UV3	60-1199-1	1" NPT Coupling w/Quartz Window	45UV5-1009
10-88	Set of 3 orifice plugs	48PT2	60-1199-2	1" BSP Coupling w/Quartz Window	45UV5-1009
35-69	1/2" NPT Heat Insulator	48PT2-UV1	60-1257	1/2" Coupling w/Quartz Window	UV1A
35-127-1	1" NPT Heat Insulator	45UV5-1009	60-1290	1/2" Coupling w/Quartz Lens	UV1A
35-127-3	1" BSP Heat Insulator	45UV5-1007/8	60-1664-3	1" NPT Swivel Mounting Flange	45UV5-1009
46-38	Quartz Lens	45UV5	60-1664-4	1" BSP Swivel Mounting Flange	45UV5-1007/8
60-302	Swivel Mounting Flange	48PT2, UV1A	61-436	Lens Cap	48PT2

INSTALLATION



CAUTION: Installer must be a trained safety control technician. Verify that Electrical Power is disconnected before starting installation.

Follow the burner manufacturer's instructions, if supplied. Otherwise proceed as follows.

Wiring Base

Mount the control wiring base on the burner or on a panel. The location should be free from excessive vibration and within the specified ambient temperature rating. The base may be mounted in any angular position.

All wiring should comply with applicable electrical codes and be suitable for 75° C min. The terminals in the wiring base are designed to permit a variety of connection methods - wire loop, eyelet, lug or quick connect. A green grounding terminal is provided for equipment bonding. Circuit recommendations are provided further on in this document. Consult with factory for assistance with non-standard applications.

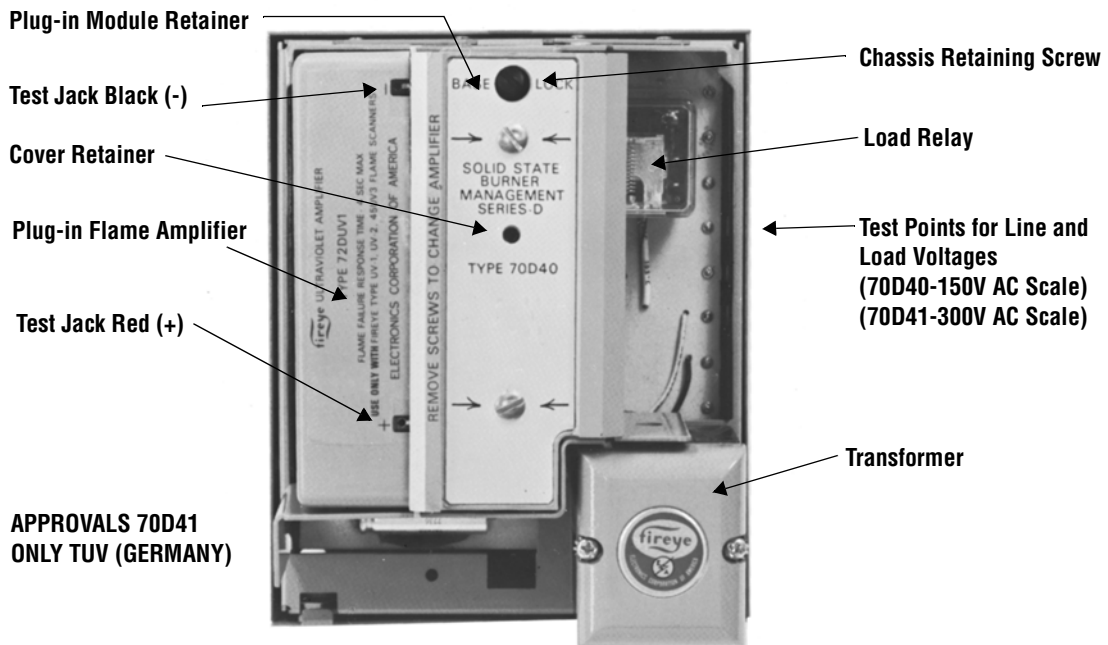

APPROVALS

70D41 only: TUV (Germany)

70D40 only:

Underwriters Laboratories Inc. Recognized: Guide MCCZ2, File MP 1537

Canadian Standards Association Approved: File LR 7989

Factory Mutual System Approved

New York Board of Standards and Appeals 743-68-SA

ELECTRICAL RATINGS

VA ratings (not specified as pilot duty) permit the connection of transformers and similar devices whose inrush current is approximately the same as their running current.

VA pilot duty ratings permit the connection of relays, solenoid valves, lamps, etc. whose total operating load does not exceed the published rating and whose total inrush current does not exceed 10 times the rating.

Running and locked rotor ratings are intended for motors. VA and VA (pilot duty) loads may be added to a motor load provided the total load does not exceed the published rating.

INSTALLING THE AMPLIFIER MODULE

To assemble or disassemble a control and its plug-in amplifier module, place the unit on a work bench, remove the two module retainer hold down screws and lift off the module retainer. The module retainer cannot be removed if the control is secured onto a wiring base. Insert the appropriate amplifier module in the slots at the left side of the unit and gently push the module into position.

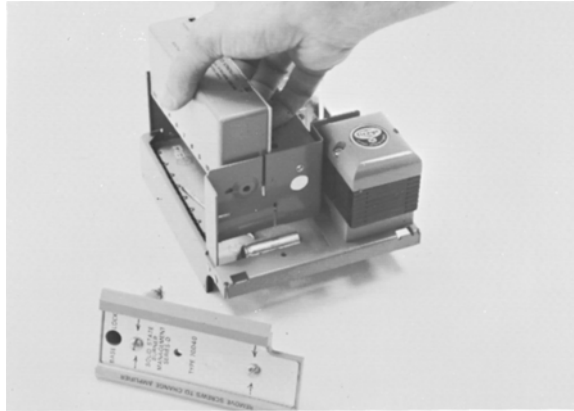

Replace the module retainer and tighten the two hold down screws. The unit cannot be installed on a wiring base if the module retainer is not in place.

INSTALLING THE CONTROL



CAUTION: Be sure that the electrical power is shut off. When the wiring is completed and the plug-in module is installed, install the type D40, D41 unit on the wiring base.

Insert the slots at the bottom of the chassis in the tabs on the base. Push the chassis into position. Insert the screwdriver through the hole at the top of the chassis and tighten the chassis retainer screw.

INSTALLATION - UV SCANNERS



CAUTION: The UV1A, UV2, UV8A, UV90 and 45UV3 ultra-violet flame scanners and associated amplifier modules are non-self-checking UV systems and should be applied only to burners that cycle often (e.g. a minimum of once per 12 hours) in order for the safety checking circuit to be exercised. (see Operation). If component checking is required during burner operation for constantly fired burners, utilize the self-checking ultra-violet flame scanners (45UV5) and associated amplifier module (72DUVS4).

Where possible, obtain the burner manufacturer's instructions for mounting the scanner. This information is available for most standard burners. The scanner mounting should comply with the following general instructions:

1. Position the UV1A, UV2, UV8A or UV90 scanner within 36 inches (900mm) of the flame to be monitored; the 45UV5 within 72 inches (1800mm), closer if possible.
2. Select a scanner location that will remain within the ambient temperature limits of the UV Scanner (UV1A, UV2, UV8A, UV90, 45UV5; 200°F, (93°C). If cooling is required, use an insulating coupling (Fireye #35-69 for UV1A, UV2 Scanners, #35-127-1 for 45UV5) to reduce conducted heat.
3. The UV1A, UV2, 45UV5 scanners are designed to seal off the sight pipe up to 1 PSI pressure. Higher furnace pressures should be sealed off. (To seal off positive furnace pressure up to 100 PSI for UV1A, UV2 scanners, install a quartz window coupling (#60-1257) For 45UV5 scanners, use #60-1199 coupling. Add cooling air to reduce the scanner sight pipe temperature.
4. Install the scanner on a standard NPT pipe (UV1A, UV8A: $\frac{1}{2}$ " , UV2: $\frac{3}{8}$ " , 45UV5: 1") whose position is rigidly fixed. If the scanner mounting pipe sights through the refractory, do not extend it



more than halfway through. Swivel flanges are available (#60-302 for UV1A, UV2 scanners, #60-1664-3, -4 for 45UV5). The sight pipe must permit an unobstructed view of the pilot and/or main flame, and both pilot and main flames must completely cover the scanner field of view.

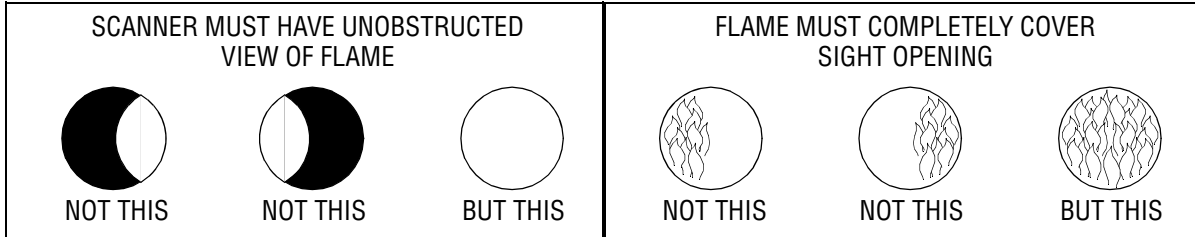

Note: Since oil and gas flames radiate more ultraviolet energy from the base of the flame than from further out in the flame this fact should be evaluated when installing the scanner sight pipe.



5. CAUTION: The scanner must not sight the ignition spark directly, or any part of the burner that can reflect the spark back to the scanner. The scanner must not see a pilot flame that is too small to reliably ignite the main flame.

- Smoke or unburned combustion gases absorb ultraviolet energy. On installations with negative pressure combustion chambers, a small hole drilled in the UV1A, UV2 sight pipe will help to keep the pipe clean and free from smoke. The 45UV5 has a $\frac{3}{8}$ " plug in the mounting flange that can be removed. For positive pressure furnaces, provide clean air to pressurize the sight pipe, if necessary.
- Two UV1A, UV2, UV8A, UV90 or 45UV3 scanners may be installed on the burner if it is necessary to view two areas to obtain reliable detection of the flame. They should be wired in parallel. Only one repetitive self-checking 45UV5 scanner may be installed on a burner.
- To increase scanner sensitivity with UV1A, UV2, UV8A scanners, a quartz lens permits location of the scanner at twice the normal distance. Use $\frac{1}{2}$ " x $1\frac{1}{2}$ " pipe nipple between UV1A Scanner and the coupling. Use $\frac{3}{8}$ " x close pipe nipple and a $\frac{1}{2}$ " x $\frac{3}{8}$ " bushing on UV2 installations.
- Request the assistance of any Fireeye field office for recommendations of a proper scanner installation on a non-standard application.

Wiring — UV Scanners

To connect the scanner to the control, the UV1A Scanner is supplied with 36"(900mm) or 72"(1800mm) of flexible cable. The UV2 is supplied with 36" (900mm) of flexible cable.

45UV5 120 VAC and 230 VAC Models



CAUTION: Be sure to check that proper line voltage is matched to L1 and L2. Applying 230 VAC to models 45UV5-1008 and 45UV5-1009 will damage scanner. 120 VAC applied to model 45UV5-1007 will not operate scanner.

The 45UV5 is supplied with four 72" (1800mm) lead wires. Install them in a suitable length of flexible armor cable and connect it to the control. A conduit connector is supplied with the scanner. Connect black wires (shutter) to terminals L1, L2; red wires (UV tube) to terminals S1, S2.

If it is necessary to extend the scanner wiring, the following instructions apply:

Scanner wires should be installed in a separate conduit. The wires from several scanners may be installed in a common conduit.

1. Selection of Wire

- Use #14, 16 or 18 wire with 75°C, 600 volt insulation for up to 100 (30.5M) foot distances (signal loss approximately 20% at 100 feet [30.5M]).
- Extended Scanner Wiring:** For extended scanner wiring up to 500 (152M) feet, and for shorter lengths to reduce signal loss, use a shielded wire (Belden 8254-RG-62/U coaxial cable, or equal) **for each scanner wire** of UV1A, UV2 and **each red wire** of the 45UV5. The ends of the shielding must be taped and not grounded.
- Asbestos insulated wire should be avoided.
- Multiconductor cable is not recommended without prior factory approval.

- High voltage ignition wiring *should not* be installed in the same conduit with flame detector wires.

Typical Scanner Installations

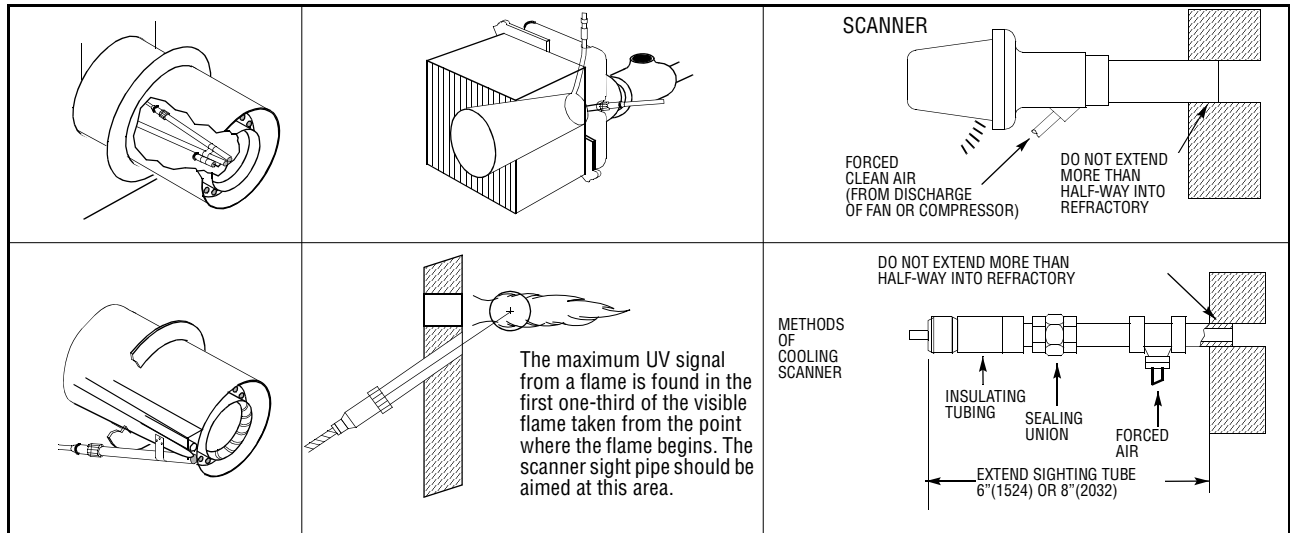

INSTALLATION - INFRARED SCANNER TYPE 48PT2

Where possible, obtain the burner manufacturer's instructions for mounting the scanner, otherwise proceed as follows:

A single scanner is used to detect both pilot and main flames. The sight pipe on which the scanner mounts must be aimed so that the scanner sights a point at the intersection of main and pilot flames.

Proper scanner positioning must assure the following:

- Reliable pilot flame signal.
- Reliable main flame signal.
- A pilot flame too short or in the wrong position to ignite the main flame reliably, must not be detected.
- Scanner must have an unobstructed view of flame being monitored.
- Flame being monitored must completely cover the scanner field of view.
- To avoid nuisance shutdowns, it is important to avoid sighting hot refractory and to keep scanner temperature low (below 140° F, 60°C).
- When the proper position has been established, drill a hole through the furnace wall and install a 4" to 8" length of threaded $\frac{1}{2}$ " black iron pipe on which to mount the 48PT2 scanner.
- When satisfactory sighting position has been confirmed by operating tests, the sight tube should be firmly welded in place.

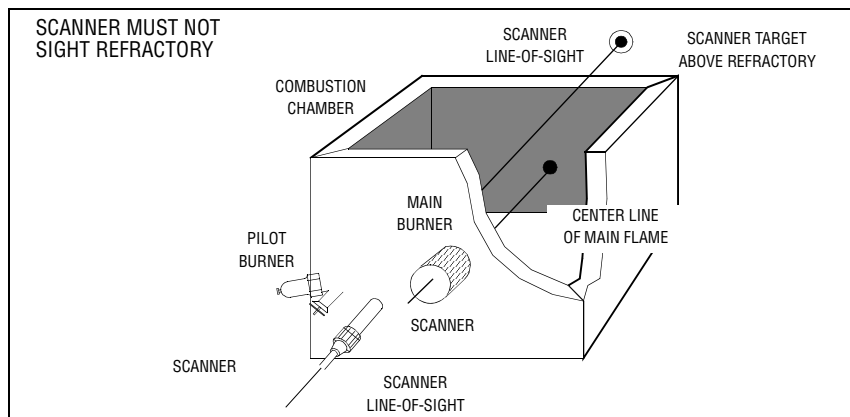

Wiring

Attach the cable supplied with the scanner to a junction box. Splice the cable wires to a pair of wires not smaller than #18. Install the complete run in a **separate conduit** to the control.



CAUTION: Continuous conduit bonding between scanner and the control is mandatory! Scanner may be located up to 100 feet (30.5M) from control. Do not pass scanner wiring through any junction box containing other wires. Do not run other wires through scanner conduit. Asbestos insulated wire should be avoided.

Keeping the Scanner Cool

The Infrared Scanner (Temperature Limit 140° F, 60° C) should never get too hot to grasp comfortably in the hand. Keep the scanner cool by one or more of the following methods.

1. Use 6" to 8" (152mm - 203mm) length of pipe between scanner and hot furnace front plate.
2. Use insulating tube (Part No. 35-69) on the end of the iron pipe.
3. Force air into sighting tube. Use Fireeye Sealing Union (Part No. 60-801).
4. Make sure sighting tube does not extend more than halfway into refractory wall.

INSTALLATION - 69ND1 FLAME ROD

The 69ND1 flame rod proves a gas pilot flame and/or main gas flame. It is a *spark plug* type unit consisting of $\frac{1}{2}$ " NPT mount, a KANTHAL flame rod, a glazed porcelain insulating rod holder and a spark plug connector for making electrical connections. The 69ND1 is available in 12" (300mm), 18" (450mm), or 24" (600mm) lengths.

The flame rod may be located to monitor only the gas pilot flame or both the gas pilot and main gas flames. It is mounted on a $\frac{1}{2}$ " NPT coupling.

The following instructions should be observed:

1. Keep flame rod as short as possible.
2. Keep flame rod at least $\frac{1}{2}$ " from any refractory.
3. Flame rod should enter the pilot flame from the side so as to safely prove an adequate pilot flame under all draft conditions.
4. If the flame is nonluminous (air and gas mixed before burning), the electrode tip should extend at least $\frac{1}{2}$ " (12.7mm) into the flame, but not more than half-way through.

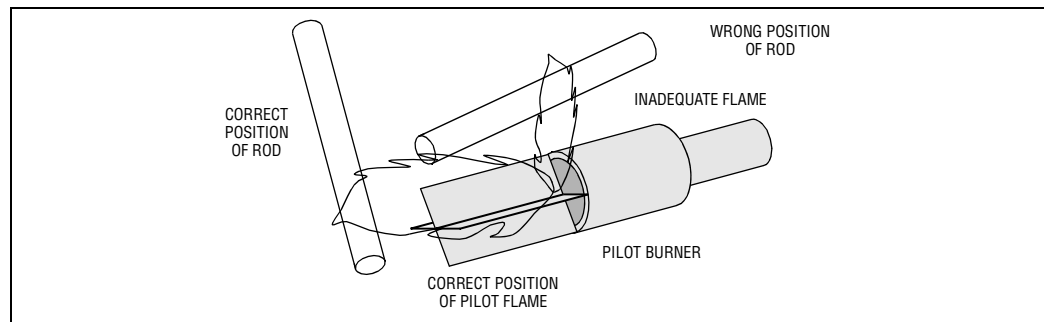

5. If the flame is partly luminous, the electrode tip should extend only to the edge of the flame. It is not necessary to maintain absolutely uninterrupted contact with the flame.
6. It is preferable to angle the rod downward to minimize the effect of sagging and to prevent it from coming in contact with any object.
7. An adequate grounding surface for the flame must be provided. The grounding surface in actual contact with the flame must be at least four times greater than the area of the portion of the flame rod in contact with the flame. It is essential to adjust the flame rod and ground area ratio to provide a maximum signal reading.

Note: Interference from the ignition spark can alter the true signal reading by adding to, or subtracting from it. This trend sometimes may be reversed by interchanging the primary wires (line voltage) to the ignition transformer and may be made ineffective by the addition of grounded shielding between the flame rod and ignition spark. This interference can also be reduced by the addition of grounded shielding between the flame rod and ignition spark.

8. Proven types of flame grounding adapters, as shown below, may be used to provide adequate grounding surface. High temperature stainless steel should be used to minimize the effect of metal oxidation. This assembly may be welded directly over the pilot or main burner nozzle.

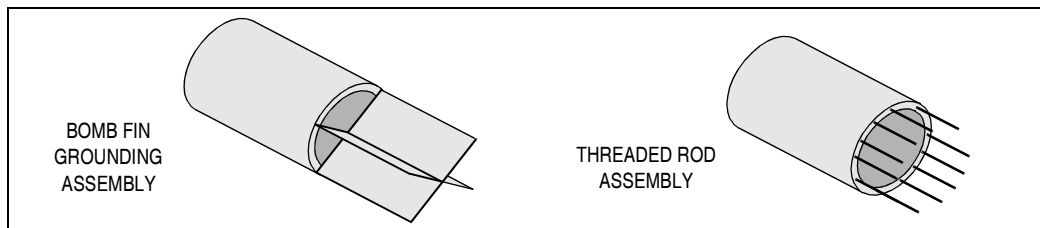

TYPICAL WIRING ARRANGEMENTS

Fireeye D40-41 controls may be used on a variety of types of fuel burners and provide a variety of functions. The typical schematic diagrams shown on the following pages illustrate a simple, and a more complex method of applying the controls to conventional burner installations. (They are for information only, and not intended to represent a complete system. Applicable safety codes may require additional circuits and interlocks.) Additionally, they may be used as flame switches, cascaded on multiple burner installations, in redundant arrangements, etc. Contact any Fireeye Sales Office for assistance in designing burner control circuits with additional functions.

FIGURE 1. SCHEMATIC DIAGRAM OF TYPE D40, D41 CONTROLS

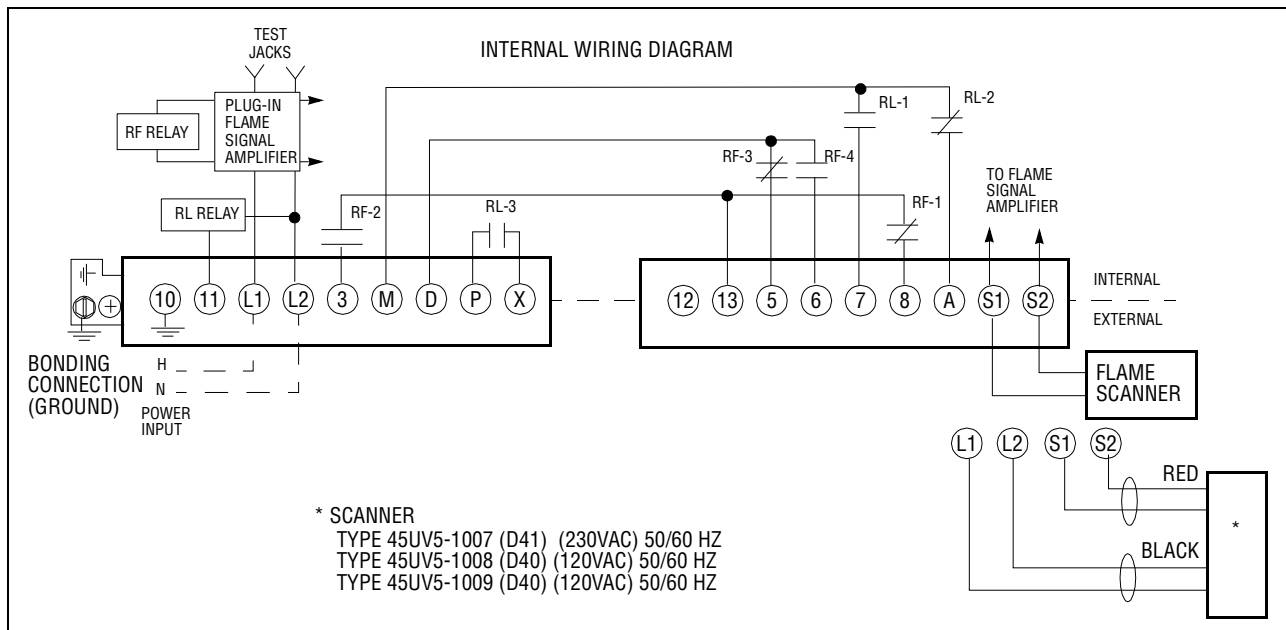



FIGURE 2. TYPICAL SCHEMATIC DIAGRAM FOR SEMI-AUTOMATIC PILOT IGNITED GAS BURNER WITH PROVED INTERMITTENT PILOT

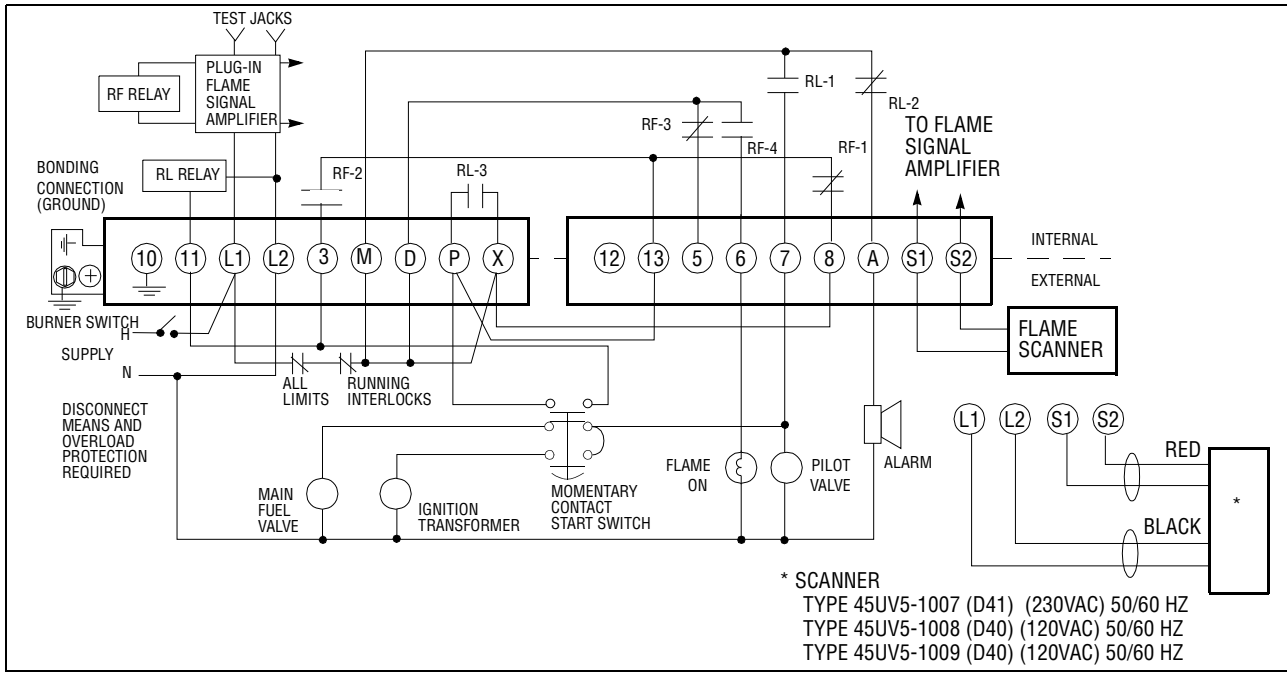
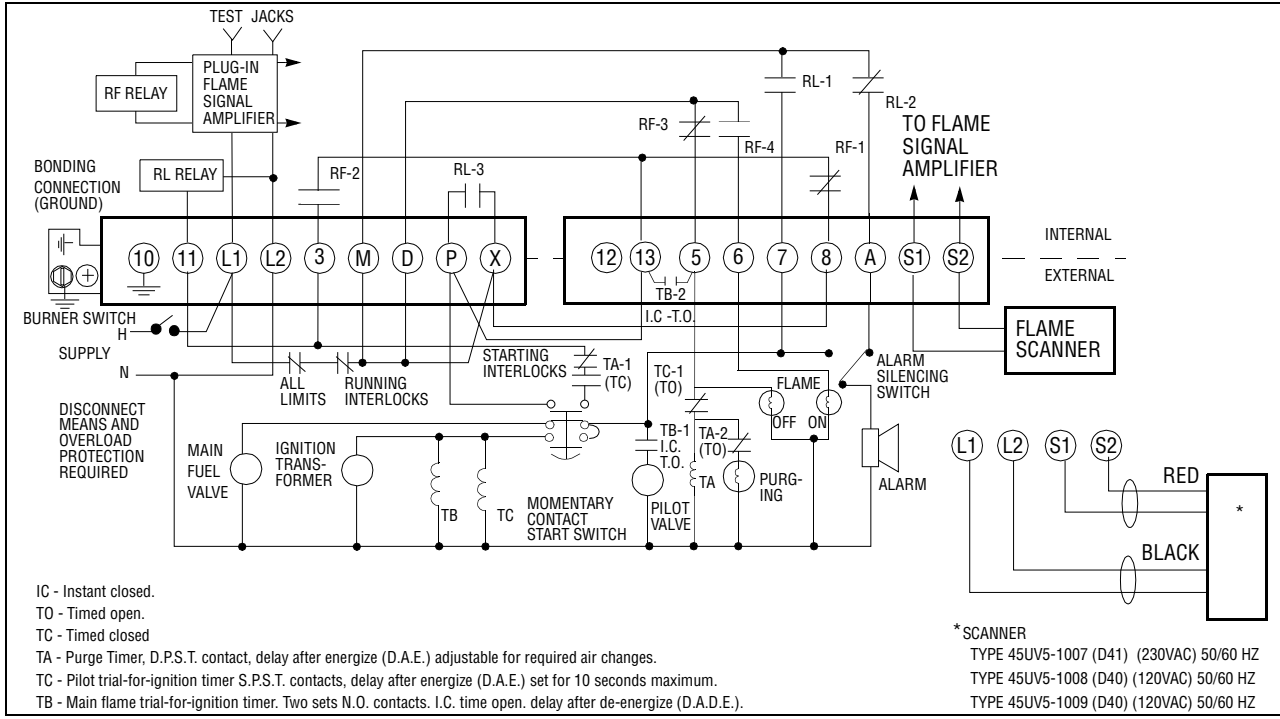

FIGURE 3. TYPICAL SCHEMATIC DIAGRAM FOR SEMI-AUTOMATIC PILOT IGNITED GAS OR OIL BURNER WITH PREPURGE, PILOT TFI, MAIN FLAME TFI AND INTERRUPTED PILOT



NOTE: When a flame rod is used, jumper S2 to the terminal board screw directly above S2 terminal on mounting base.

The self-checking circuitry in the 72DUVSIT and 72DUVS4 amplifiers is designed to be used with only one 45UV5 type scanner connected. When two 45UV5 scanners are used, wire the two black L1 and L2 leads in parallel and switch the two red S1 and S2 leads with a relay or selector switch.

CAUTION: Only one scanner can be in the S1 and S2 circuit at one time.



DESCRIPTION OF OPERATION OF TYPICAL SINGLE BURNER SYSTEM (refer to Figure 3)

NOTE: With 72DIR1 Amplifier, Terminals L1 and L2 must be powered for 15 seconds before the flame signal amplifier will operate.

1. With power applied, burner switch closed, limit switches closed, air flow and fuel interlock closed, the “Flame Off” light, the purge timer TA and “Purging” light are energized. The “Alarm Silencing” switch should be switched to the “Silent” position.
2. When the prepurge period expires, contacts TA2 open and de-energize the “Purging” light. Contacts TA1 close. The operator depresses and holds the momentary contact “Start” switch.
3. The circuit to Terminals P-3-11 is completed through the starting interlocks and contacts TA, and the RL relay is energized. Terminal 7 is energized. The “Alarm Silencing” switch should be switched to the “Alarm” position.
4. The ignition transformer, timers TB and TC, and the pilot gas valve are energized. Pilot flame is established and detected. Relay RF is energized.
5. The operator releases the “Start” switch. The ignition transformer and timers TB and TC are de-energized. The main fuel valve is energized.
6. When the main flame trial for ignition expires, contacts TB1 open and de-energize the pilot valve, TB2 open and reset the purge timer.
7. The burner will continue to fire until power is shut off, or the limit and operating control circuit opens, or a flame failure occurs.

INSTALLATION TESTING

Testing Fireye D40-41 controls is accomplished with the use of an AC-DC test meter with 1,000 ohm/volt input impedance, or a digital meter with 500K input impedance or greater. Test points are located on the chassis board to assist with measuring line and load voltages. For this test the meter should be set on the 150 volt AC scale (D40), 300 volt AC scale (D41). Test jacks are located on the amplifier for measuring flame signal strength. For this test the meter should be set on a scale to read a normal 20-25 volts DC. The DC test voltage may vary plus or minus 5 volts, but should not fluctuate with an acceptable flame signal.

Note: The Fireye 45UV5 is a repetitive self-check scanner that contains a highly reliable shutter that closes every 4 seconds to initiate a system check. When the shutter closes, the test jack voltage should go down to approximately zero, and then back to the normal reading.

Normal Pilot Test

1. Manually shut off the main fuel supply.
2. Initiate a normal start.
3. When the pilot flame is present, observe the test meter. If the meter reading is low, or fluctuates, increase the size of the pilot flame, improve the alignment of the sight pipe, move the flame scanner closer to the pilot flame, or verify that the flame scanner is clean.

Minimum Pilot Test

This test insures that the flame scanner will not detect a pilot flame too small to reliably light the main flame. It should be made by a qualified person on every new installation and following any repositioning of the flame scanner.

1. Manually shut off the main fuel supply.
2. Initiate a normal start up.
3. When the pilot flame is detected, observe the test meter and reduce the size of the pilot flame until the flame relay just remains energized.
4. Manually, slowly turn on the main fuel which must light immediately from the reduced pilot flame.



CAUTION: If main flame light off is delayed, shut off the fuel immediately. Realign the flame scanner so that pilot flame detection requires a larger pilot flame. Repeat this test until the main flame lights reliably with a minimum pilot flame.

5. After the minimum pilot test is completed satisfactorily, increase the pilot flame to normal size.



This test should be made on every new installation and following change-out of the control and/or flame detector, any repositioning of the flame detector, air/fuel ratio adjustment or any other changes that may interfere with reliable light-off of the main fuel.

Test for Spark Pickup (Only required on UV Controls)

1. Shut off all fuel.
2. Initiate a start-up with only the spark ignition energized.
3. Observe the test meter. It should read no more than one volt. If a test meter reading reveals that UV from the spark is being detected, realign the sight pipe to eliminate it. Relocate the spark or install a shield to obscure the spark signal from the flame scanner.
4. If a flame scanner sighting change has been made, recheck for normal pilot flame detection.

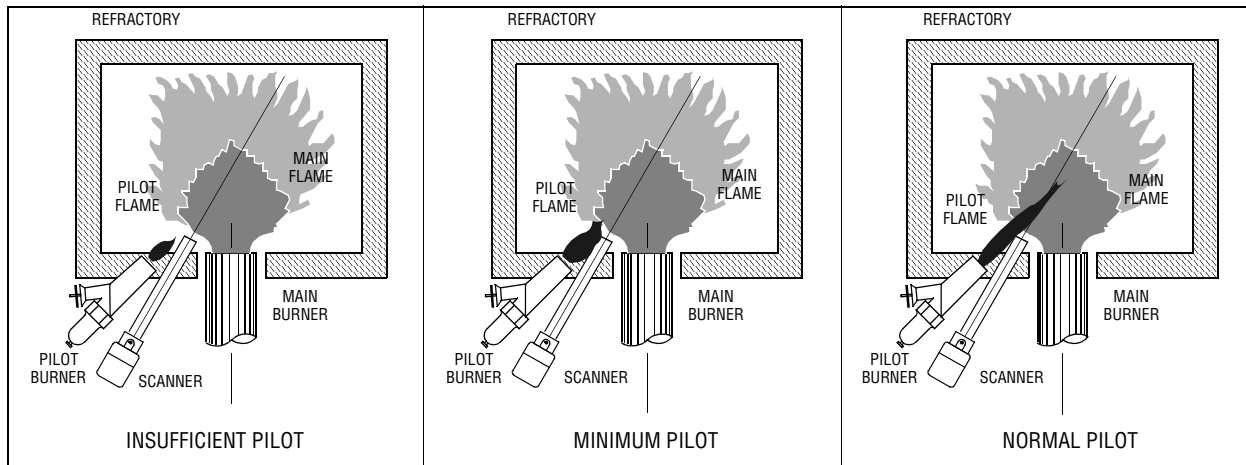

EXTERNAL METER CONNECTIONS

The test jacks are located on the amplifier card, if external access is desired for a panel meter the shown below will assist you in locating the position to drill through on the front cover. The hole sizes should be large enough to accommodate the body of the meter probes. The test jacks accept meter probes up to .080" or 2mm diameter.

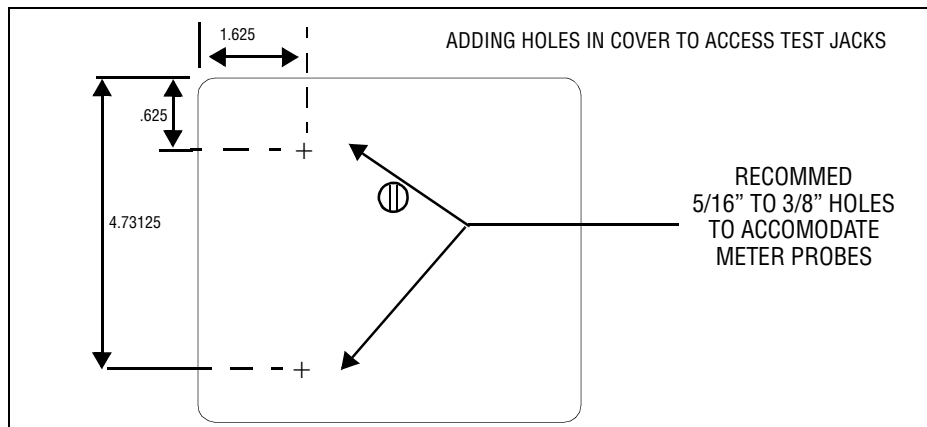

MAINTENANCE

Humidity Effects

It is good practice to minimize any possible adverse effects of high humidity by keeping control equipment continuously powered, even during periods when it is not in use.

Scanner

The viewing window must be kept clean. Even a small amount of contamination will reduce the flame signal reaching the flame scanner. A routine schedule should be set up. Wipe the scanner with a clean soft cloth. If necessary, dampen the cloth with concentrated detergent.

Type 48PT2 scanners include a replaceable #4-263-1 Firetron cell.

Type 45UV5 and 45UV3 scanners include a replaceable #4-314-1 UV tube.

RECOMMENDATION — Periodic Safety Checks

It is recommended that a procedure be established to test at least once a month, the complete flame safeguard system. The test should verify flame failure safety shutdown, limit switch and interlock function and positive fuel cutoff when the valves are de-energized.

Rotation

It is recommended that control and scanner units purchased as spares be installed periodically.

FIGURE 4. Mounting UV1A/48PT2 Scanners

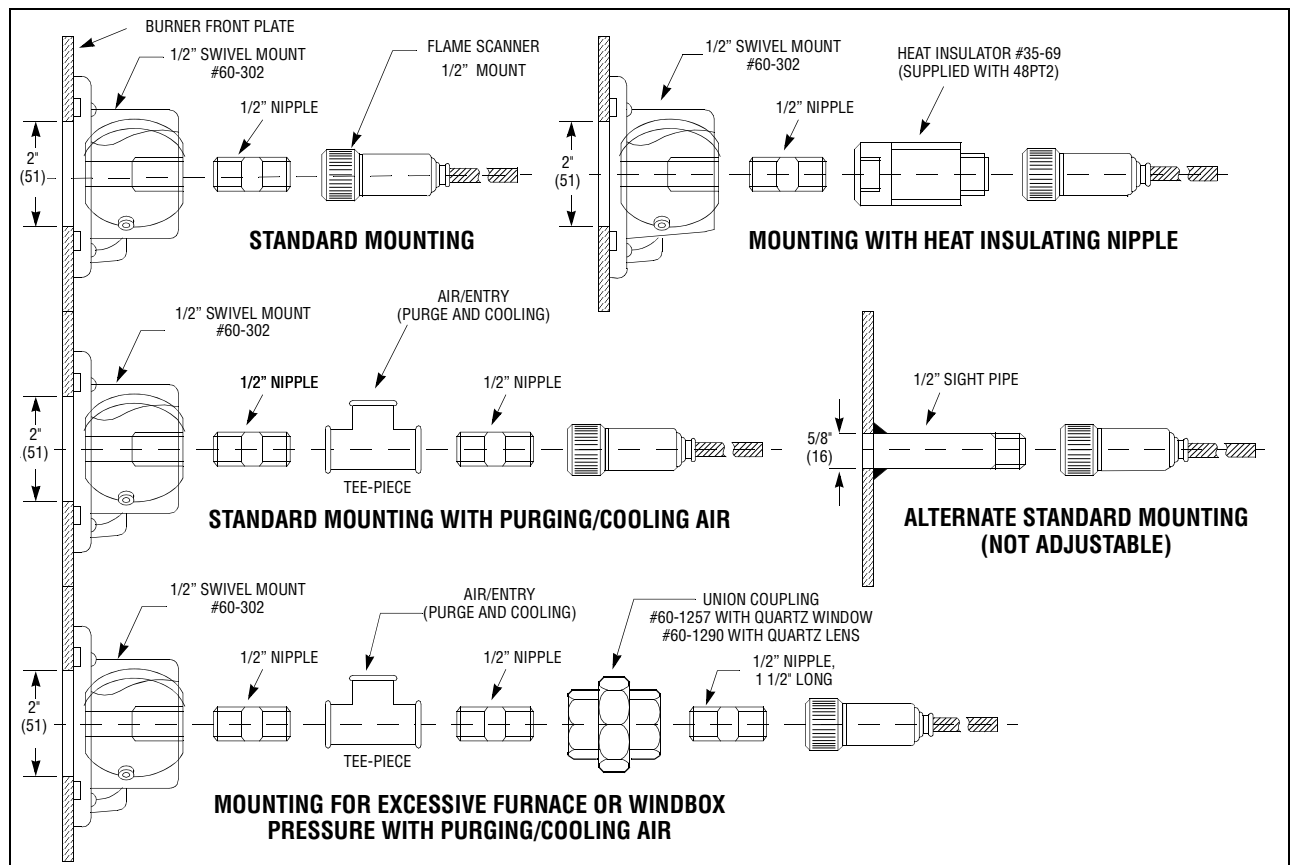
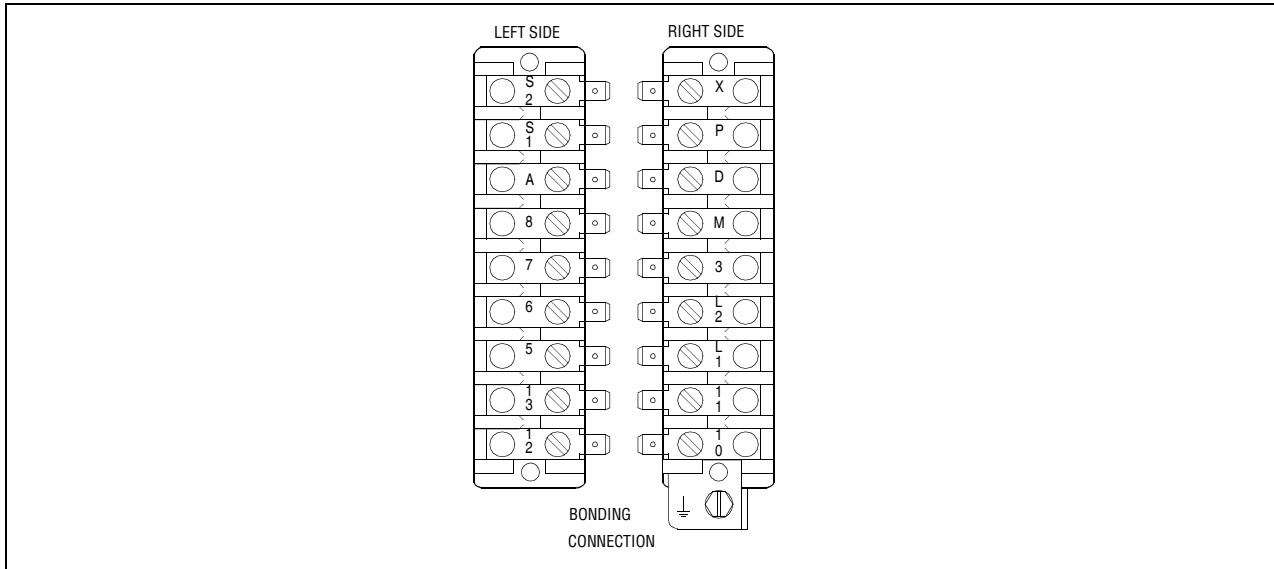
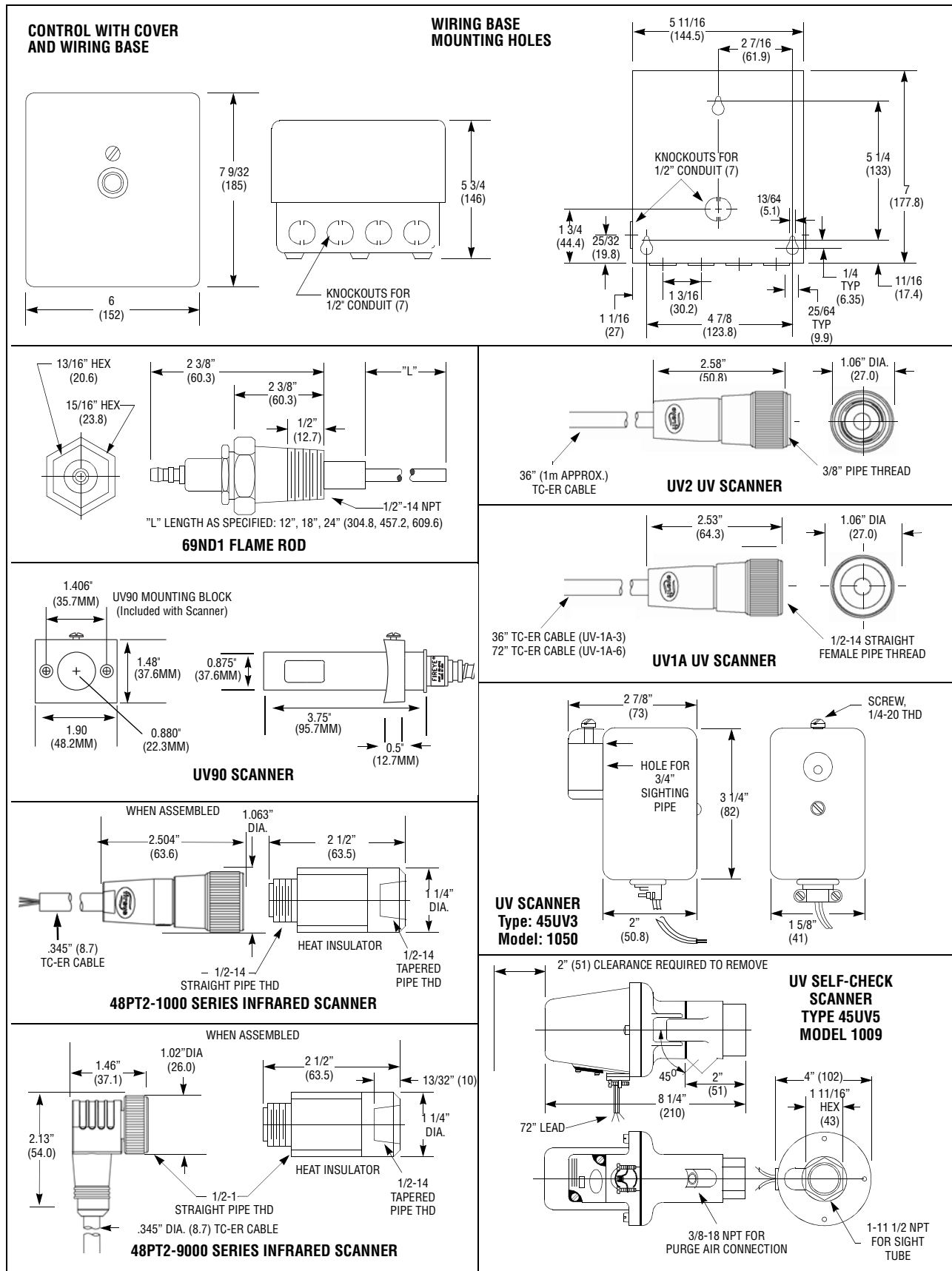

FIGURE 5. WIRING BASE TERMINAL LAYOUT



Component Dimensions





NOTICE

When Fireeye products are combined with equipment manufactured by others and/or integrated into systems designed or manufactured by others, the Fireeye warranty, as stated in its General Terms and Conditions of Sale, pertains only to the Fireeye products and not to any other equipment or to the combined system or its overall performance.

WARRANTIES

FIREYE guarantees for *one year from the date of installation or 18 months from date of manufacture* of its products to replace, or, at its option, to repair any product or part thereof (except lamps and photocells) which is found defective in material or workmanship or which otherwise fails to conform to the description of the product on the face of its sales order. **THE FOREGOING IS IN LIEU OF ALL OTHER WARRANTIES AND FIREYE MAKES NO WARRANTY OF MERCHANTABILITY OR ANY OTHER WARRANTY, EXPRESS OR IMPLIED.** Except as specifically stated in these general terms and conditions of sale, remedies with respect to any product or part number manufactured or sold by Fireeye shall be limited exclusively to the right to replacement or repair as above provided. In no event shall Fireeye be liable for consequential or special damages of any nature that may arise in connection with such product or part.



FIREYE®
3 Manchester Road
Derry, New Hampshire 03038 USA
www.fireeye.com

D-4041
MAY 10, 2011
Supersedes October 20, 2006