



FIREYE 25SU3-2000 RACK-MOUNTED FLAME SAFEGUARD AMPLIFIER



DESCRIPTION

The **25SU3-2000** is a Flame Safeguard Amplifier used to detect the presence or absence of a flame in a single or multi-burner environment. The 25SU3-2000 also maximizes burner discrimination with its ability to accurately differentiate the pulse rates produced by the scanners.

The 25SU3-2000 has the capacity to receive pulse inputs from two flame scanners, “A” and “B,” either separately or in combination. In addition, the 25SU3-2000 has two logic programs available, called “Scanner Option 1” and “Scanner Option 2.” Within these two scanner options, the user may select different operating parameters, and select the scanner or scanners that will provide the pulse input for that option. Switching between “Scanner Option 1” and “Scanner Option 2” is accomplished by an external dry contact input to the amplifier. The dynamic range for the 25SU3-2000 amplifier is 1900 pulses per second, which is consistent with the output range provided by Fireeye scanners. The pulse rate output of each scanner can be checked by the user, thus facilitating the maintenance of each scanner.

The design platform of the 25SU3-2000 is based on the global 19 inch format with the unit operating on either 24 VAC or 24 VDC. Fireeye offers a full rack (60-2471-3), half-rack (60-2471-1) or surface mount rack (60-2530), and filler plates for mounting the 25SU3-2000 amplifiers, as well as several different power supplies for various scanner/amplifier combinations. See Ordering Information.

The 25SU3-2000 amplifier provides remote communications capability to a PLC using either Allen-Bradley DF1 or MODBUS communication protocol. Consult factory for details.

FEATURES

- Keypad Entry system
- Password protection to avoid unauthorized alteration of the user-set (programmed) parameters.
- Eight character alpha-numeric display.
- Front panel LED Status Indicator.
- Adjustable Independent Flame Relay Pull-In and Drop-Out Thresholds.
- Adjustable Flame Failure Response Time (FFRT) (1 to 6 secs.).
- Adjustable Independent Flame Relay Delay On Time (0 to 10 secs.).
- Capable of analyzing signals from two scanners.
- One Form C SPDT Marginal Alarm relay.
- One fused DPDT Form C Flame relay.
- One 4 - 20mA analog output (used to measure flame signal—scalable).
- Remote communications capability to a PLC. Consult factory for details.



COMPATIBLE FIREYE FLAME SCANNERS

TYPE/MODEL	FREQ. Hz	WAVE-LENGTH (nanometers)	MOUNT THREADS	AMBIENT TEMP. MAX., MIN.	SAFETY APPROVALS	BULLETIN	NOTES
When TUV Agency approval is required, select one of the following:							
45UV5-1101	50	180 - 250	1" BSP	200°F (93°C) - 40°F (-40°C)	APAVE, DIN, FM	CU-22	See Note 1.
45RM1-1003	50/60	450 - 1,000	1" BSP	150°F (65°C) - 40°F (-40°C)	FM, APAVE, DIN	CU-26	See Note 1.
45RM2-1001	50/60	700 - 2,500	1" BSP	150°F (65°C) - 40°F (-40°C)	FM, APAVE, DIN	CU-26	See Note 1.
45RM4-1001	24VDC	700-2,500	1" BSP	150°F (65°C) - 40°F (-40°C)	FM, APAVE, DIN	CU-31	—
When TUV Agency approval is NOT required, select any scanner from either above or below.							
45UV5-1000	60	180 - 250	1" NPT	200°F (93°C) - 40°F (-40°C)	FM, UL	CU-22	See Note 1.
45UV5-1010	60	180-250	1" BSP	200°F (93°C) - 40°F (-40°C)	FM	CU-22	See Note 1.
45RM1-1001	50/60	450 - 1,000	1" NPT	150°F (65°C) - 40°F (-40°C)	FM	CU-26	See Note 1.
45RM2-1000	50/60	700-2,500	1" NPT	150°F (65°C) - 40°F (-40°C)	FM	CU-26	See Note 1.
45RM4-1000	24VDC	700 - 2,500	1" NPT	150°F (65°C) - 40°F (-40°C)	FM	CU-31	—
45FS1-1000	24VDC	700 - 2,500	1" NPT	150°F (65°C) - 4°F (-20°C)	FM	CU-32	—
45FS1-1001	24VDC	700 - 2,500	1" BSP	150°F (65°C) -4°F (-20°C)	FM	CU-32	—
45UVFS1-1000	24VDC	290-390	1" NPT	131°F (55°C) - 4°F (-20°C)	FM	CU-32	—
45UVFS1-1001	24VDC	290-390	1" BSP	131°F (55°C) - 4°F (-20°C)	FM	CU-32	—
Note 1: Requires 19UVPS-2120 or -2220 power supply or 19MPS-2000 power supply.							

The 25SU3-2000 is also compatible with scanners in explosion-proof housings and fiber optic versions.



ORDERING INFORMATION

Part Number	Description
25SU3-2000	Rack mount flame amplifier
Mounting Racks:	
60-2471-1	Half mounting rack. Includes one (1) 60-2478 connector.
60-2471-3	Full mounting rack. Includes one (1) 60-2478 connector.
60-2530-1	Surface mount rack. Refer to Bulletin CU-44.
60-2530-2	Surface mount rack with clear hinged cover. Refer to Bulletin CU-44.
Mounting Adaptors	
192SU3-2120	Adaptor (120 VAC) to retrofit 25SU3-2000 to 60-1706 or 60-1499 wiring rack.
192SU3-2220	Adaptor (220 VAC) to retrofit 25SU3-2000 to 60-1706 or 60-1499 wiring rack.
Filler Plates	
60-2490-2	Front filler plate for mounting racks. Approx .4" (2 HP)
60-2490-4	Front filler plate for mounting racks. Approx .8" (4 HP)
60-2490-6	Front filler plate for mounting racks. Approx 1.2" (6 HP)
60-2490-8	Front filler plate for mounting racks. Approx 1.6" (8 HP)
60-2490-10	Front filler plate for mounting racks. Approx 2.0" (10 HP)
Power Supplies	
60-2470-1	Power supply. 110 VAC Input/24 VDC, 2.5 Amps Output for 25SU3-2000 amplifiers and low voltage scanners. Includes 60-2482 connector.
60-2470-2	Power supply. 220-240 VAC Input/24 VDC, 2.5 Amps Output for 25SU3-2000 amplifiers and low voltage scanners. Includes 60-2482 connector.
19UVPS-2120	Power supply. 110 VAC Input for up to six (6) line voltage scanners only. Refer to Bulletin CU-38.
19UVPS-2220	Power supply. 220 VAC Input for up to six (6) line voltage scanners only. Refer to Bulletin CU-38.
19MPS-2000	Multi-purpose power supply for two (2) 25SU3-2000 amplifiers and up to four (4) low voltage or line voltage flame scanners. Refer to Bulletin CU-45.
Connectors	
60-2478	Screw terminal straight style (12 AWG) connector for 25SU3-2000 amplifier and 19UVPS power supply.
60-2480	Screw terminal Y style (12 AWG) connector for 25SU3-2000 amplifier and 19UVPS power supply.
60-2481 ^a	Screw terminal connector (12 AWG) for 60-2470 and 19MPS-2000 power supplies.
60-2482	Spade terminal connector for 60-2470 and 19MPS-2000 power supplies.
Replacement Fuses	
23-93	Replacement power fuse for 25SU3-2000 (3.0 Amp. fast-acting type).
23-182	Replacement fuse for RF1 flame relay contacts for 25SU3-2000 (1.5 Amp. fast-acting type).

a. Screw terminal connector (60-2481) requires 2" of side clearance for wiring. Installing the power supplies in either end position of the full or half rack will not provide adequate clearance to wire connector.

HARDWARE COMPONENTS

The following figures show the components making up the 19 inch amplifier/rack system.

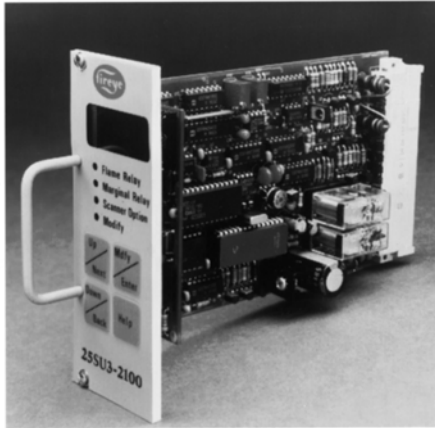

25SU3-2000 AMPLIFIER WITH KEYPAD/DISPLAY
PART NUMBER 25SU3-2000



POWER SUPPLY
PART NUMBER 60-2470-1 (110 VAC)
60-2470-2 (220 VAC)

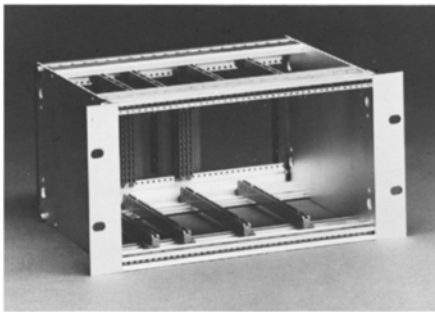

HALF RACK PART NUMBER 60-2471-1

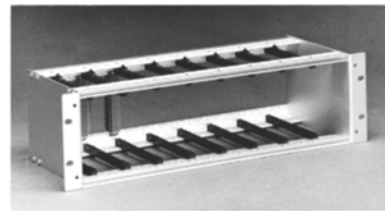

FULL RACK PART NUMBER 60-2471-3

SPECIFICATIONS 25SU3-2000 Amplifier

DIMENSIONS (Figure 1)

Height:	5.06 inches (128.5 mm)
Depth:	7.0 inches (203.2 mm)
Width (Front Panel):	1.98 inches (50.3 mm) 10HP
Thickness (Front Panel):	0.0625 inches (1.588 mm)
Shutter Check Timings:	Open: 3.5 sec. Closed: 0.5 sec.



FIGURE 1. 25SU3-2000 DIMENSIONS

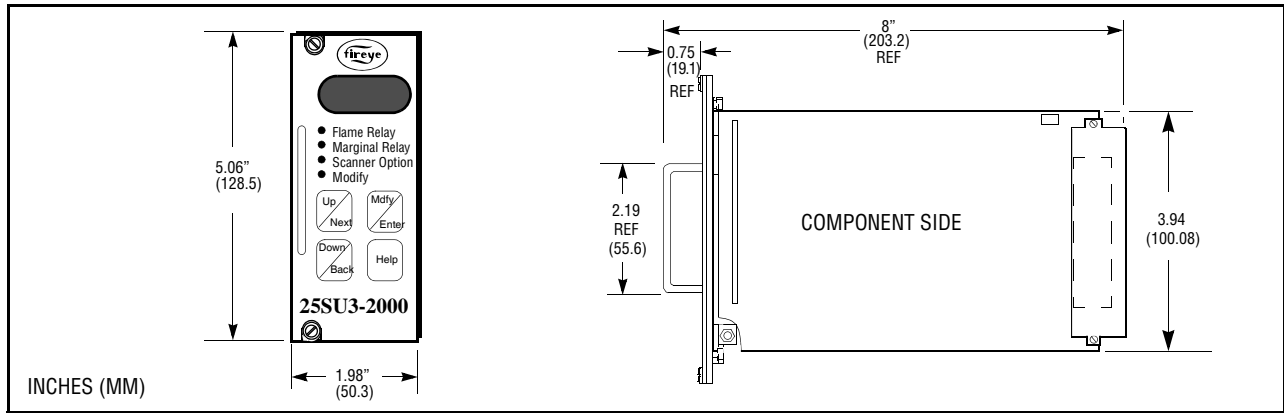

A standard full 19" rack has a usable inside width of 16.8" (426.80mm). This allows for up to 8 amplifiers per rack.

SIGNAL INPUTS — Two flame scanner inputs.

ANALOG OUTPUT — 4-20mA output. Current Sourcing. I.C. max. connected load = 1000 ohms.

OUTPUTS —

Contacts available:

- One flame relay changeover (DPDT) contacts.
- One set fused contacts (RF1) 1.5A.
- One marginal alarm relay (SPDT)

Contact Ratings: Flame Relay and Marginal Relay

- Minimum:** 40mA resistive @ 24 VDC
40mA resistive @ 250 VAC
- Maximum:** 3A resistive at 24 VDC
4A resistive at 250 VAC

Contact Material: Silver cadmium oxide.

INPUT VOLTAGES — 24VAC (+10%, -15%) 50/60 Hz or 24 VDC (+/-10%)

POWER CONSUMPTION — Control with One Scanner: 5 VA
Control with Two Scanners: 7.5 VA

TEMPERATURE RANGE— Operating: - 4°F to +140° F
(- 20° C to +60° C)
Storage: - 4° F to +176° F
(- 20° C to +80° C)

HUMIDITY — 0% TO 85% R.H. non-condensing.

FLAME FAILURE RESPONSE TIME—1 to 6 secs (user-selectable).

SHIPPING WEIGHT — 1 lb. (454 grams)

MOUNTING — Rack Mount

KEYPAD/DISPLAY— Four (4) positive action membrane keys with embossed tactile feedback.
Eight (8) Character Alpha-Numeric LED Display.



FRONT PANEL STATUS LEDs

Four status LEDs

1. **Flame Relay** - Indicates (ON/OFF) Status of Flame Relay
2. **Marginal Alarm Relay** - Indicates (ON/OFF) Status of Marginal Alarm Relay, pulses for diagnostics (see page 12).
3. **Scanner Option** - Allows user to combine the signals from the connected scanner or scanners in a variety of logical configurations.
Steady State — Scanner Option 1 (SCN OPT1).
Blinking State — Scanner Option 2 (SCN OPT2).
4. **Modify** — Indicates that the Modify Mode is invoked and the user can make changes to parameters in the Setpoint group.

ELECTRONICS

The control is a microprocessor based system. The integrity of the micro-controller is checked by a “watchdog relay.” This relay state is periodically updated by the micro-controller and is dependent on the proper execution of the code programmed within the operating software. The scanners operate in the system in a self-checking mode.

Periodically, a self-check pulse is sent to each scanner to determine if the scanner is “false firing.”

Connector

The Full Rack (P/N **60-2471-3**) and the Half Rack (P/N **60-2471-1**) offered by Fireeye each come with one screw terminal straight connector (P/N **60-2478**). The connector is a Euro standard DIN 41612 Type F connector consisting of 32 total pins with 16 pins on each side. Additional connectors can be ordered through Fireeye:

Screw Terminal Straight Style (12 AWG) (P/N **60-2478**).

The Surface Mount Racks, P/N 60-2530-1, -2 are supplied complete with connectors.

Replaceable Fuses

The 25SU3-2000 is designed with replaceable fast-acting fuses for the amplifier power and the flame relay contacts. The fuses are located on the printed circuit board near the connector. The fuse for the flame relay is marked F2 and RF1. The fuse for the 25SU3-2000 amplifier power is marked F1 and PWR. See Figure 4 for fuse location.

SPECIFICATIONS OF MOUNTING RACKS

There are several mounting racks for the installation of the 25SU3-2000 amplifiers and power supplies: full rack (60-2471-3), half rack (60-2471-1) or surface mount rack (60-2530).

FIGURE 2. DIMENSIONS — SHOWN IN MM (INCHES)

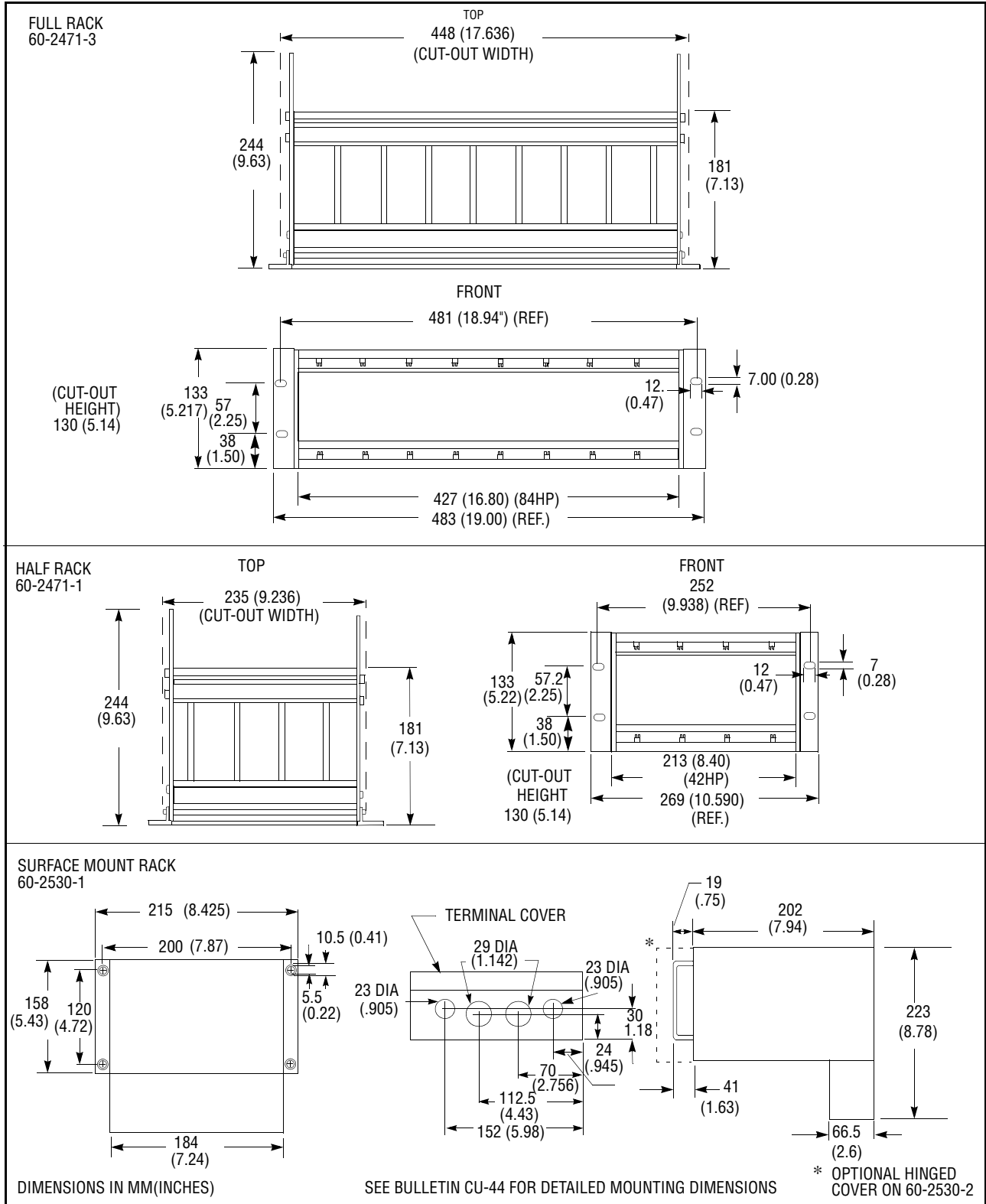

Full Rack (60-2471-3)

The full rack has an aperture opening of 84 HP (Horizontal Pitch) or 16.8 inches (426.72 mm). 1 HP is approximately .2 inch. The 25SU3-2000 amplifier and 19MPS-2000 power supply each have a width of 10 HP (approx. 2"). The 60-2470 and 19UVPS power supplies have a width of 8 HP (approx. 1.6"). A full rack can accommodate up to 8 amplifiers or 7 amplifiers and 1 power supply.

Half Rack (60-2471-1)

The half rack has an aperture opening of 42 HP (Horizontal Pitch) or 8.4 inches (213.36 mm). 1 HP is approximately .2 inch. The 25SU3-2000 amplifier and 19MPS-2000 power supply each have a width of 10 HP (approx. 2"). The 60-2470 and 19UVPS power supplies have a width of 8 HP (approx. 1.6"). A half rack can accommodate up to 4 amplifiers or 3 amplifiers and 1 power supply.

Surface Mount Rack (60-2530)

The surface mount rack has an aperture opening of 30 HP. It is designed to accept up to 2 amplifiers and 1 19MPS-2000 multi-purpose power supply.

FILLER PLATES

Filler plates are provided to cover any openings in the racks after the installation of the amplifiers and power supplies. Filler plates are offered in 2, 4, 6, 8, and 10 HP widths. 1 HP is approximately .2 inch. To determine the number and types of filler plates required, subtract the HP widths of each installed amplifier and power supply from the aperture opening of the mounting rack.

Mounting Racks		Amplifier and Power Supplies		Filler Plates	
Part #	Width	Part #	Width	Part #	Width
60-2471-3	84 HP	25SU3-2000	10 HP	60-2490-2	2 HP
60-2471-1	42 HP	19MPS-2000	10 HP	60-2490-4	4 HP
60-2530	30 HP	60-2470	8 HP	60-2490-6	6 HP
		19UVPS	8 HP	60-2490-8	8 HP
				60-2490-10	10 HP

FRONT PANEL OF 25SU3-2000

FIGURE 3. 25SU3-2000 FRONT PANEL

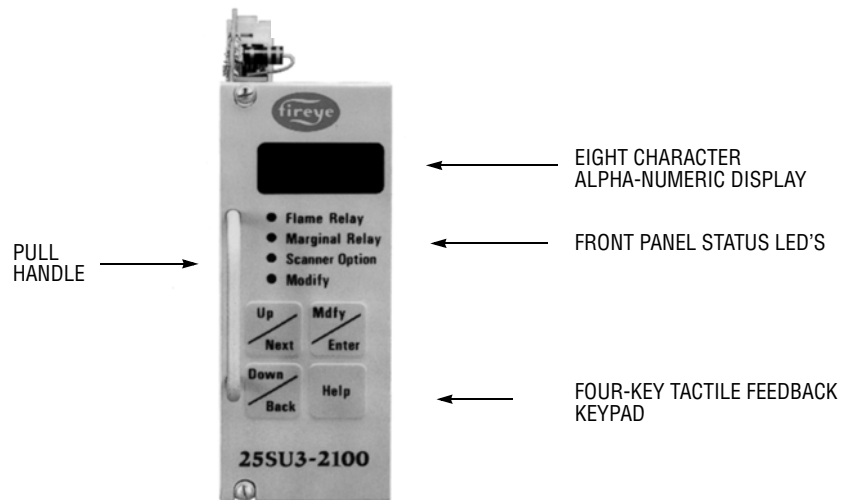



EIGHT CHARACTER ALPHA-NUMERIC DISPLAY

Information on the set-up and operation of the 25SU3-2000 is displayed on a high intensity eight character alpha-numeric display. The operating parameters and system setpoints are displayed using a mnemonic code, up to eight characters in length, which serve as an abbreviated descriptor for that value. A full length descriptor providing a detailed description of each value is also available via the "Help" key. When powered up, the display will show the flame signal for scanner A.

STATUS LED's: Four (4) status LED's are located on the front panel to provide the following information:

Flame Relay LED: This LED is lit when the flame relay is energized.

Marginal Relay LED: This LED indicates the status of the marginal alarm relay or annunciates a Shutter Check Failure. Refer to Marginal Alarm section under Setpoints Menu for details.

Scanner Option LED

This LED indicates which Scanner Logic Option is selected.

- **Steady State** —Scanner Logic Option 1 is selected. (Terminal Z16 to Z12 is open).
- **Pulsing** —Scanner Logic Option 2 is selected. (Terminal Z16 to Z12 is closed).

Modify LED: This LED is lit when the user is in the Setpoints menu and the "Modify/Enter" key has been pressed to change the value of a setpoint.

FOUR KEY KEYPAD

The 25SU3-2000 has four (4) positive action embossed, membrane keys with tactile feedback to review and modify the setpoints and operating parameters of the amplifier. The keys are multi-functional in that each key performs double duty, depending on when they are pressed.

Up/Next key

1. This key will display the next operating parameter or system setpoint and its associated value.
2. When the user is in the "Setpoints" menu and the Modify/Enter key is pressed, this key will increase the value associated with that setpoint.

Down/Back key

1. This key will display the previous operating parameter or system setpoint and its associated value.
2. When the user is in the "Setpoints" menu and the Modify/Enter key is pressed, this key will decrease the value associated with that setpoint.

Mdfy/Enter key

1. When the user is in the "Status" menu, this key will enter the "Setpoints" menu.
2. When the user is the "Setpoints" menu, this key will allow the user to modify the value of that setpoint. The "Modify" LED will light.

Help

1. This key will display the full length descriptor associated with the mnemonic code of each operating parameter and setpoint. After two minutes, the display will return to the mnemonic.
2. When the user is in the "Setpoints" menu, pressing this key **twice** will return to "Status" menu.

FIGURE 4. LOCATION OF FUSES

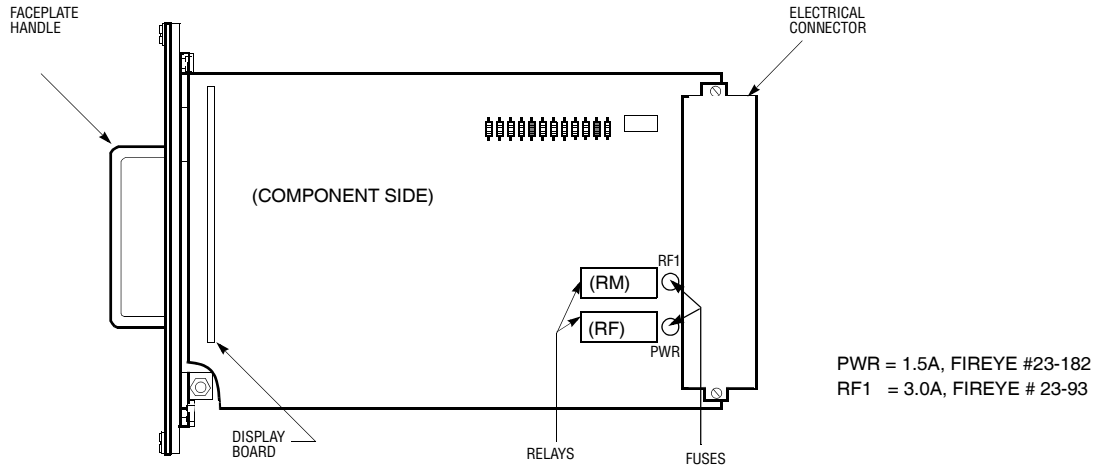

OPERATION

The key feature of the 25SU3-2000 amplifier is its ability to properly detect and discriminate between flame on and flame off conditions. A key feature of the 25SU3-2000 is its ability to differentiate and display the actual flame signal pulses received from the flame scanners, and program the pull in and drop out values for the flame relay based on the signals from one or more scanners (see Scanner Logic Option).

Flame Relay: If the flame relay is de-energized, the 25SU3-2000 will not energize the flame relay until the flame signal (based on the logic configuration selected via the Scanner Logic Option) is above the “Flame Relay On Threshold” setpoint (RF ON) for the programmed Flame Relay Delay On time (RF DLY). Once energized, the flame relay will not be de-energized until the average flame signal falls below the Flame Relay Off Threshold setpoint (RF OFF) for the length of the Flame Failure Response Time setpoint (FFRT).

Marginal Alarm Relay: The marginal alarm relay is energized if the flame signal (based on the logic configuration selected via the Scanner Logic Option) is below the Marginal Alarm Threshold (MRG ALM) for at least ten (10) seconds and the flame relay is energized.

STATUS AND SETPOINTS MENU

The 25SU3-2000 will display the operating parameters and system setpoints under the Status menu and Setpoints menu respectively. In addition, the user can modify the values of the system setpoints. For all operating parameters and system setpoints, the display will show the mnemonic code, followed by its associated value. If the **HELP** key is pressed, the full length descriptor associated with the operating parameter or setpoint will be displayed, followed by its associated values.

Example: In the Status menu, the display shows SCN A=486. If the **HELP** key is pressed, the display will show SCANNER A PULSE RATE (full length descriptor) followed by 486 (value).

Press the **MDFY/ENTER** key to switch from the Status menu to the Setpoints Menu.

Press the **HELP** key twice to switch from the Setpoints menu to the Status menu.

STATUS MENU

The Status menu displays the current operating parameters of the 25SU3-2000.

Note: These operating parameters cannot be modified.



Mnemonic	Full Length Descriptor	Value
SCN A = XXX	SCANNER A PULSE RATE	Actual flame signal pulses from Scanner A. Range = 0-1900 pulses.
SCN B = XXX	SCANNER B PULSE RATE	Actual flame signal pulses from Scanner B. Range = 0-1900 pulses.
RF RLY	FLAME RELAY STATUS	ON / OFF
MRG ALARM	MARGINAL ALARM RELAY STATUS	ON / OFF
4-20 OUT	ANALOG OUTPUT	4-20 Ma output proportional to the flame signal(s) based on the selected Scanner Logic Option. Value displayed in percent (%). Output scaled under "Setpoints" menu.

SETPOINTS MENU

The Setpoints menu contains the various system setpoints that are configurable by the user. Following is a description of some of the system setpoints.

Scanner Logic Option (SCN OPT): This setpoint allows the user to combine the flame signal pulses from the connected scanners in a variety of Logical Configurations (see below) to control the flame relay. Each Scanner Logic Option has its own separate flame on (RF ON), flame off (RF OFF), marginal alarm (MRG ALM), flame failure response time (FFRT), and 4-20 mA scaling (4-20 RNG) setpoints.

It is not necessary to have two scanners connected to utilize the **Scanner Option 1 & 2 and the Logic Options** features. This example will clarify this. There is a need to discriminate between pilot and main flame with one scanner. Usually pilot flame provides considerably less signal than main flame and with conventional controls it would require connecting two scanners, each with different sensitivity settings. The burner management system would then switch out the pilot scanner during the main flame stabilization period, and it would then be up to the main flame scanner to detect the main flame. With the 25SU3-2000 and one scanner connected, Scanner Option 1 (**SCN OPT1**) would have Logic Option 1, "A ONLY" and the thresholds would be set to detect the pilot flame at one signal level. Scanner Option 2, "A ONLY," and its thresholds would be set to detect the main flame at a higher signal level. During the main flame stabilization period the burner management system would then switch from Scanner Option 1 to Scanner Option 2. If the main flame did not provide signal that was above Logic Option 2's flame off threshold the system would indicate a flame failure.

- A ONLY** - Pulses from Scanner A determine the Flame Relay status. Scanner B is ignored.
- B ONLY** - Pulses from Scanner B determine the Flame Relay status. Scanner A is ignored.
- A AND B** - Pulses from both scanners must be above the pull-in threshold to energize the Flame Relay. Pulses from either scanner below the drop-out threshold will drop the flame relay out.
- A OR B** - Pulses from either scanner must be above the Flame Relay pull-in threshold to energize the Flame Relay and pulses from both must be below the drop-out threshold to de-energize the Flame Relay.
- A XOR B** - Pulses from both scanners must be above the Flame Relay threshold to energize the Flame Relay. Pulses from both scanners must be below the drop-out threshold to de-energize the Flame Relay.
- A PLUS B** - Pulses from Scanners A and B are added together. The resulting sum determines the Flame Relay status.



SCANNER USEAGE OPTIONS						
	A ONLY	B ONLY	A AND B	A OR B	A XOR B	A PLUS B
Flame Relay Energized	A > Pull In	B > Pull In	A > Pull In AND B > Pull In	A > Pull In OR B > Pull In	A > Pull In AND B > Pull In	The SUM of A plus B > Pull In
Flame Relay De-energized	A < Drop Out	B < Drop Out	A < Drop Out OR B < Drop Out	A < Drop Out AND B < Drop Out	A < Drop Out AND B < Drop Out	The SUM of A plus B < Drop Out
4-20 mA Output Follows:	A Pulses	B Pulses	The LOWER of A or B Pulses	The HIGHER of A or B Pulses	The LOWER of A or B Pulses	The SUM of A plus B Pulses
MARGINAL ALARM RELAY ENERGIZED WHEN:						
	A < Threshold	B < Threshold	A or B < Threshold	A and B < Threshold	A or B < Threshold	The sum of A plus B < Threshold

	Marginal Alarm RELAY Action	Marginal Alarm LED Action
Shutter Fault Scanner A	On/Off 4 sec.	On/Off 4 sec.
Shutter Fault Scanner B	On/Off 2 sec.	On/Off 2 sec.
NOTE 1: The Shutter Fault Annunciation takes priority over a Marginal Alarm Annunciation.		

To “Pull-In” the Flame Relay, the scanner signal received must be above the flame relay pull-in threshold for the required amount of user selected delay on time.

To “Drop-Out” the Flame Relay, the scanner signal received must be below the flame relay drop-out threshold for the required “flame failure response time.”

Flame Relay On Threshold (RF ON): The flame relay is energized when the flame signal (based on the logic configuration selected via the Scanner Logic Option) is above this setpoint.

Flame Relay Off Threshold (RF OFF): The flame relay is de-energized when the flame signal (based on the logic configuration selected via the Scanner Logic Option) is below this setpoint.

The above setpoints (RF ON and RF OFF) select the pull-in and drop-out values of the flame relay, allowing the amplifier to accurately discriminate between flame on/flame off conditions regardless of the flame on to flame off ratio. An attempt should be made to maintain a pull-in/drop-out ratio of no less than 2 to 1 in order to achieve satisfactory performance.



WARNING: When installing self-checking ultra-violet flame scanners (e.g. 45UV5-1000), the sensitivity of the UV tube may drop within 24-48 hours after initial installation or after returning the scanner to service after extended periods of non-use. This phenomenon is due to “burn-in” of the UV tube. This loss of sensitivity would result in a drop in flame signal from the UV scanner which could effect the pull- in or drop-out of the flame relay. The user should check on the flame signal strength of the UV scanner 1-2 days after initial installation (or a return to service) to ensure an adequate flame signal.

Flame Failure Response Time (FFRT): The flame relay is de-energized when the flame relay drops below the Flame Relay Off Threshold setpoint (RF OFF) for the length of the FFRT time. Selections are from 1 to 6 seconds with a separate selection for the 45FS1/45UVFS1 scanner (45FS1). When the 45FS1/45UVFS1 scanners are used, the total FFRT is **additive** between the 25SU3-2000 amplifier and the 45FS1/45UVFS1 scanner. The FFRT time of the 25SU3-2000 amplifier is considered instantaneous for the selection 45FS1. The total FFRT would then be the FFRT setpoint of the 45FS1/45UVFS1 scanner. Refer to Bulletin CU-32 for additional information.

4-20 mA Output Range (4-20 RNG): This setpoint will scale the 4-20 mA output signal to match the anticipated flame signal. For example, if 0-500 is selected, at 250 pulses, the output will be 12 mA. The available selections are 0-250, 0-500, and 0-1000.



Flame Relay Delay On (RF DLY): The flame relay is not energized until the flame signal (based on the logic configuration selected via the Scanner Logic Option) is above the “Flame Relay On Threshold” setpoint (RF ON) for the time programmed under this setpoint (RF DLY), Allowable values are 0 to 10 seconds. This setpoint helps to ensure a stable flame signal before energizing the flame relay.

Marginal Alarm Threshold (MRG ALM): The marginal alarm relay is energized when the flame signal (based on the logic configuration selected via the Scanner Logic Option) is below this setpoint and the flame relay is energized. The flame signal must be below this setpoint for at least ten (10) seconds before the marginal alarm relay is energized. The Shutter Check Failure annunciation takes priority over the Marginal Alarm annunciation.

THE STATUS AND SETPOINT GROUPS

THE STATUS GROUP

MNEMONIC	DESCRIPTOR	VALUE
SCN A = XXX	SCANNER A PULSE RATE	Scanner A input flame signal pulse rate, 0-1900 pulses/sec.
SCN B = XXX	SCANNER B PULSE RATE	Scanner B input flame signal pulse rate, 0-1900 pulses/sec.
RF RLY	FLAME RELAY STATUS	'OFF' / 'ON'
MRG ALRM	MARGINAL ALARM RELAY STATUS	'OFF' / 'ON'
4-20 OUT	ANALOG OUTPUT	Current flame signal strength scaled by user.

THE SETPOINT GROUP

Factory Defaults: The factory has set Default Values for the SETPOINT GROUP.

SETPOINT	DEFAULT VALUE	
SCN OPT1	A OR B	SCANNER LOGIC OPTION 1 SETPOINTS
RF ON 1	400 PULSES/SEC	
RF OFF 1	200 PULSES/SEC	
MRG ALM1	300 PULSES/SEC	
FFRT 1	1 SEC (SEE WARNING)	
SCN OPT2	A OR B	SCANNER LOGIC OPTION 2 SETPOINTS
RF ON 2	400 PULSES/SEC	
RF OFF 2	200 PULSES/SEC	
MRG ALM2	300 PULSES/SEC	
FFRT 2	1 SEC (SEE WARNING)	
RF DLY	0 SEC.	COMMUNICATION SETPOINTS
4-20 RNG	0-250 PULSES/SEC	
CTS DLY	50 mSec	
CMM PROT	A-B	
MAST NUM	255 = *377	
DEV NUM	1 = *1	
BAUD	1200 baud	
REV NUM	3 (or latest)	
LV1 PASS	2	
LV2 PASS	5	
SYSTEM TEST	OFF	



WARNING: As delivered from factory, FFRT1 and FFRT2 are configured for 1 second. THE FFRT SHOULD BE SELECTED TO COMPLY WITH APPLICABLE SAFETY CODES AND REGULATIONS

25SU3-2000 SETPOINTS AND ALLOWABLE VALUES

MNEMONIC	DESCRIPTION	VALUE
SCN OPT1	SCANNER USAGE OPTIONS 1	One of the following: A ONLY A OR B B ONLY A AND B A PLUS B A XOR B
RF ON 1	FLAME RELAY ON THRESHOLD 1	Scanner pulse rate (pps) required to turn flame relay ON (5 - 1900)
RF OFF 1	FLAME RELAY OFF THRESHOLD 1	Scanner pulse rate (pps) required to turn flame relay OFF (5 - 1900)
MRG ALM1	MARGINAL ALARM THRESHOLD 1	Threshold level required to energize marginal flame relay (5- 1900pps).
FFRT 1	FLAME FAILURE RESPONSE TIME (SEE WARNING)	Time to flame relay off 4 secs 1 secs 5 secs 2 secs 6 secs 3 secs 45FS1 (For use with FS1 scanner only)
SCN OPT2	SCANNER USAGE OPTIONS 2	One of the following: A ONLY A OR B B ONLY A AND B A PLUS B A XOR B
RF ON 2	FLAME RELAY ON THRESHOLD 2	Scanner pulse rate (pps) required to turn flame relay ON (5-1900)
RF OFF 2	FLAME RELAY OFF THRESHOLD 2	Scanner pulse rate (pps) required to turn flame relay OFF (5-1900)
MRG ALM2	MARGINAL ALARM THRESHOLD 2	Threshold level required to energize marginal flame relay (5-1900pps)
FFRT 2	FLAME FAILURE RESPONSE TIME 2 (SEE WARNING)	Time to flame relay off 4 secs 1 secs 5 secs 2 secs 6 secs 3 secs 45FS1 (For use with FS1 scanner only)
RF DLY	FLAME RELAY DELAY ON	Consecutive secs. for flame signal to be above ON threshold to Flame Relay ON. Range: 0 - 10 secs.
4-20 RNG	4-20 MA OUTPUT RANGE	Scalable analog output range of flame intensity: 0-250 0-500 0-1000
CTS DLY	CLEAR TO SEND DELAY	Delay before response message sent; 0-255 milli-seconds
CMM PROT	COMMUNICATION PROTOCOL	Communication protocol selected (DF1 or MODBUS)
MAST NUM	MASTER NUMBER DECIMAL = *OCTA	Master number; multi-master communication system; 0-255
DEV NUM	DEVICE NUMBER DECIMAL = * OCTA	Local address number; 1-254.
BAUD	BAUD RATE	Baud rate for communication: 300 1200 2400 4800 9600
REV NUM	REVISION NUMBER	Software revision number
LV1 PASS	ENTER LEVEL 1 PASSWORD	Storage for user-programmed password.
LV2 PASS	ENTER LEVEL 2 PASSWORD	Storage for user-programmed password.
SET LVL1	SET LEVEL 1 PASSWORD	Storage for operator entered password.
SET LVL2	SET LEVEL 2 PASSWORD	Storage for user-programmed password.
SYS TEST	SYSTEM TEST	System Test is: 2 Password Required; No 5 minute time-out after last key stroke.



PASSWORD PROTECTION

The 25SU3-2000 comes from the factory with a default password set at 2, 5 (LV1 PASS = 2 and LV2 PASS = 5). After powering up the unit, it will be necessary to enter this password before any setpoint parameter can be modified or before any new password can be put in.

ENTERING THE FACTORY DEFAULT PASSWORD LV1 PASS = 2 and LV2 PASS = 5

After the unit has been powered up, PRESS the **Mdfy/Enter** key to enter the SETPOINT GROUP.

1. PRESS the **Up/Next** key until **LV1 PASS 0** is displayed
PRESS the **Mdfy/Enter** key. The **MODIFY LED** on the front panel will illuminate.
PRESS the **Up/Next** key until 2 appears in the display.
PRESS the **Mdfy/Enter** key. The display shows LV1 PASS 2. The **MODIFY LED** on the front panel goes out.
2. PRESS the **Up/Next** key until LV2 PASS 0 is displayed.
PRESS the **Mdfy/Enter** key. The **MODIFY LED** on the front panel will illuminate.
PRESS the **Up/Next** key until 5 appears in the display.
PRESS the **Mdfy/Enter** key. The display shows LV2 PASS 5. The **MODIFY LED** on the front panel goes out.

After entering the password, the user can now modify any of the setpoint values.

CHANGING THE PASSWORD

Once the proper password have been entered, the mnemonic codes displayed for password protection **will change to** Set Level 1 (SET LVL 1) and Set Level 2 (SET LVL 2) followed by their respective passwords. The user can now change either of the two password levels. Following is an example to change the Level 1 password from 02 to 10, and the Level 2 password from 05 to 20:

1. PRESS the **Up/Next** key until SET LV1 2 is displayed.
PRESS the **Mdfy/Enter** key. The **MODIFY LED** on the front panel will illuminate.
PRESS the **Up/Next** key until 10 appears in the display.
PRESS the **Mdfy/Enter** key. The display shows SET LV1 10. The **MODIFY LED** on the front panel goes out.
2. PRESS the **Up/Next** key until SET LV2 5 is displayed.
PRESS the **Mdfy/Enter** key. The **MODIFY LED** on the front panel will illuminate.
PRESS the **Up/Next** key until 20 appears in the display.
PRESS the **Mdfy/Enter** key. The display shows SET LV2 20. The **MODIFY LED** on the front panel goes out.

A new password has now been set to LV1 PASS = 10 and LV2 PASS = 20.

REMOVING PASSWORD PROTECTION

The user can remove software password protection by setting both Level 1 password and Level 2 password to zero. Any user will then be able to modify any setpoint without entering a new password. When the password protection has been removed, the mnemonic codes are SET LVL1 and SET LVL 2, followed by the value zero. The user can enable the password protection mode by changing the Level 1 and/or Level 2 password to a value other than zero.

FIVE MINUTE TIME OUT

Once the password has been entered or set, there is a five (5) minute timeout period after any key is pressed, within which the user can modify any setpoint parameter without having to re-enter the password. If no keys are pressed for a period of five minutes, then the password must be entered to gain access to the modify mode.

EXAMPLE: The user has just entered the PASSWORD. The user will now have five minutes to Press a Key (e.g. make a modification to a setpoint parameter) before the amplifier will revert back to the STATUS GROUP, and the PASSWORD will have to be re-entered.



If the user PRESSES a KEY within the five minute period, then the user will have five minutes from the latest key stroke to PRESS a KEY before the amplifier will revert back to the STATUS GROUP, and a PASSWORD will have to be re-entered.

SYSTEM TEST 2 — BYPASS TIMEOUT

Once the user has entered the PASSWORD, modifications can be made to any of the SETPOINT parameters. Modifications can continue to be made as long as the user PRESSES a KEY within the five minute time-out limit. There may be a situation in which the user may enter the PASSWORD, make the modifications required, and may not want to leave the unit capable of undergoing further modifications by others who could make modifications without entering the PASSWORD within the five minute time-out period.

SOLUTION: The user can enter the PASSWORD, make the modifications, and then go into SYSTEM TEST 2, so that there is no five minute time-out. The PASSWORD must be entered again before modifications can be made.

First, Go to the SETPOINT Group from the STATUS GROUP by Pressing the Modify/Enter key.

PRESS the **Up/Next** key until SYS TEST OFF is displayed.

PRESS the **Mdfy/Enter** key. The **MODIFY LED** on the front panel will illuminate.

PRESS the **Up/Next** key until 2 appears in the display.

PRESS the **Mdfy/Enter** key. The **MODIFY LED** on the front panel will go out.

EXAMPLE — PROGRAMMING SETPOINTS

To help the user in making SETPOINT changes via the MODIFY MODE, the following example with the key stroke sequence is given:

Set-up the following:

- SCN OPT2 (A AND B)
- RF ON 2 (500)
- RF OFF 2 (250)
- MRG ALM2 (300)
- FFRT 2 (1 SEC)
- 4-20 RNG (1000)

1. PRESS the **Mdfy/Enter** key. The display will show the Scanner Option chosen. If SCN OPT2 is displayed, then Go to Step 2. Otherwise, PRESS THE **Up/Next** key until SCN OPT2 is displayed.
2. If A AND B is displayed, then Go to Step 3. Otherwise, PRESS the **Mdfy/Enter** key. The **MODIFY LED** on the front panel will illuminate. PRESS the **Up/Next** key until A AND B is displayed. PRESS the **MDFY/Enter** key. The **MODIFY LED** will go out. The display will show SCN OPT2 A AND B.
3. PRESS the **Up/Next** key until RF ON 2 and a numerical value is displayed. If the numerical value is 500, then Go to Step 4. Otherwise, PRESS the **Mdfy/Enter** key. The **MODIFY LED** will illuminate. PRESS either the **Up/Next** key or the Down/Back key until a value of 500 is displayed. PRESS the **MDFY/Enter** key. The **MODIFY LED** will go out. The display shows RF ON 2 500.
4. PRESS the **Up/Next** key until RF OFF 2 and a numerical value is displayed. If the numerical value is 250, then Go to Step 5. Otherwise, PRESS the Modify/Enter key. The **MODIFY LED** will illuminate. PRESS either the **Up/Next** key or the Down/Back key until a value of 250 is displayed. PRESS the **MDFY/Enter** key. The **MODIFY LED** will go out. The display shows RF OFF 2 250.
5. PRESS the **Up/Next** key until MRG ALM2 and a numerical value is displayed. If the numerical value is 300, then Go to Step 6. Otherwise, PRESS the **Mdfy/Enter** key. The **MODIFY LED** will illuminate. PRESS either the **Up/Next** key or the Down/Back key until a value of 300 is displayed. PRESS the **MDFY/Enter** key. The **MODIFY LED** will go out. The display shows MRG ALM2 300.
6. PRESS the **Up/Next** key until FFRT2 and the number of seconds appears on the display. If the time is 1 sec, stop here. Otherwise, PRESS the **Mdfy/Enter** key. The **MODIFY LED** will illu-

minate. PRESS either the **Up/Next** key or the Down/Back key until 1 sec is displayed. PRESS the **MDFY/Enter** key. The **MODIFY LED** will go out. The display will show FFRT2 1 SEC.

7. PRESS the **Up/Next** key until 4-20 RNG and a numerical value is displayed. If the numerical value is 0-1000, stop here. Otherwise, PRESS the **Mdfy/Enter** key. The **MODIFY LED** will illuminate. Press either the **Up/Next** key or the Down /Back key until 0-1000 is displayed. PRESS the **Mdfy/Enter** key. The **MODIFY LED** will go out. The display will show 4-20 RNG 0-1000.

INSTALLATION OF AMPLIFIERS AND POWER SUPPLIES

The Half Rack (60-2471-1) is shipped with 4 factory mounted rack guides with their centerlines (center groove of the rack guide) in positions 3, 13, 23, and 33 with their extensions facing right (as viewed from the top and front). See Figure 5. The half rack also includes one 60-2478 connector screwed into position 34. The Full Rack (60-2471-3) is shipped with 8 factory mounted rack guides with their centerlines (center groove of the guide rack) in positions 5, 15, 25, 35, 45, 55, 65, and 75 with their extensions facing right (as viewed from the top and front). The full rack also includes one 60-2478 connector screwed into position 76. Each position corresponds to approx .2 of an inch, or 1 HP (Horizontal Pitch). Each rack guide is factory shipped 10HP apart.

Note: The position of the rack guides is referenced to the centerline of the rack guide.

FIGURE 5.

FACTORY DEFAULT GUIDES FOR HALF RACK

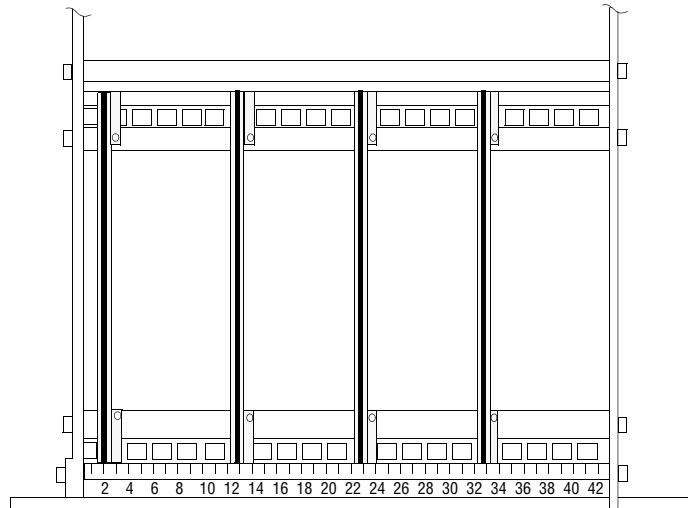

To install 25SU3-2000 amplifiers or 19MPS-2000 power supplies¹

Since the 25SU3-2000 amplifier and 19MPS-2000 power supplies are both 10HP wide, the rack guides do not have to be moved. The connectors are installed 1 position away from the centerlines of the rack guides. Screw the connector (60-2478 or 60-2480) as required into positions 4, 14, and 24 on the half rack, and positions 6, 16, 26, 36, 46, 56, and 66 on the full rack.

Note: If desired, filler plates are available to close any openings. Refer to the section on “Filler Plates.”

To install the 19UVPS-2120, -2220 power supply

The 19UVPS power supply is only 8HP wide, and the rack guides are factory installed 10HP apart. There are two options for installing the power supply.

1. Use the existing rack guides. The connector for the 19UVPS power supply (60-2478 or 60-2480) is installed 1 position away from the centerline of the appropriate rack guide (e.g. screw the connector into position 14 if the power supply is mounted in the rack guide in position 13. If

¹ The 19MPS-2000 power supply is a dual voltage device (120VAC or 220VAC). It is shipped in the 220 VAC position. Be sure to select the correct voltage (via the switch on the printed circuit board), prior to installation.

desired, a 2 HP filler plate (60-2490-2) will be required to close the opening between the 19UVPS power supply and 25SU3-2000 amplifier.

- Assuming the amplifiers are installed in the far right positions, move the rack guide that is closest to the amplifiers 2 positions to the right as viewed from the front of the rack (e.g. from rack guide position 13 to position 15 on the half rack). Install the connector (60-2478 or 60-2480) one position away from the centerline of the rack guide (e.g. rack guide moved to position 15, screw connector into position 16).

For example: A full rack (60-2471-3) has five (5) amplifiers mounted in the factory installed rack guide positions 35, 45, 55, 65, and 75. Connectors are screwed into positions 36, 46, 56, 66, and 76. To install the 19UVPS power supply, move the rack guide from position 25 to position 27, and install the connector into position 28.

To install the 60-2470-1, -2 power supply

The 60-2470-1, -3 power supply is only 8HP wide and the rack guides are factory installed 10HP apart. **In addition, the 60-2470-1, -3 is a right hand mount** (the right side of the 60-2470-1,-2 power supply slides into the rack guides). The other power supplies and the 25SU3-2000 amplifiers are left hand mount. Because the rack guides are factory installed 10HP apart for left hand mounts, the rack guides used for the 60-2470-1, -2 power supply **must be moved** so their extensions **face left** (as viewed from the front and top). See Figure 5.

Assuming the amplifiers and 19UVPS power supply (if used) are installed in the far right positions:

- Remove an unused rack guide.
- Reverse the position of the rack guide so the extensions are facing left (as viewed from the front or top).
- Place the rack guide (with its extensions facing left) in the position immediately to the left of the rack guide for the amplifiers (or 19UVPS power supply). For example, the rack guide for the amplifier is installed in position 35 of the full rack, install the rack guide for the 60-2470-1, -2 power supply so its centerline is in position 34.
- Install the connector (60-2482) 5 positions to the left of the rack guide (e.g. the centerline of the rack guide is in position 34, install the connector in position 29).

FIGURE 6. RACK GUIDE POSITIONS FOR 3 AMPLIFIERS AND 60-2470 POWER SUPPLY

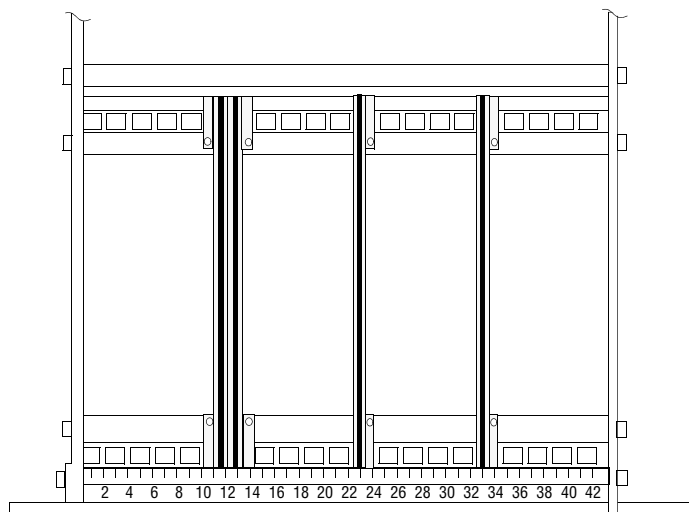

MOUNTING, GROUNDING AND SHIELDING THE 25SU3-2000

The Fireye 25SU3-2000 and associated rack is designed to be mounted in a metal enclosure where the product will reside permanently. Proper shielding of the rack must be observed.



CAUTION: The shielded scanner cable (P.N. 59-470, 59-471) will be used to connect the scanner. It is very important to verify that the shield (wire) of this cable is connected to the chassis earth ground via the rear of each amplifier to terminal D32 or Z32.

Terminals D32 or Z32 must be connected to a good earth ground.

Note: The shield must be tied to a good earth ground at only one end of the scanner cable (at the amplifier end).

FIGURE 7. WIRING DIAGRAM OF TYPE F CONNECTOR (RACK BACK VIEW)

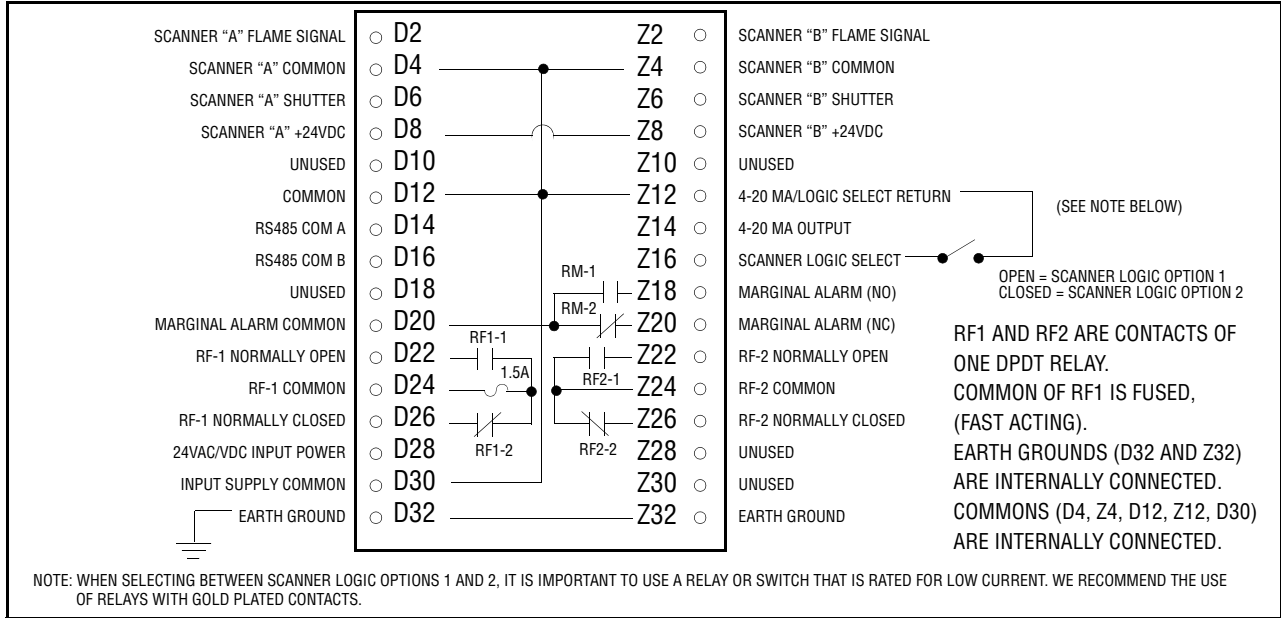

FIGURE 8. POWER WIRING DIAGRAM: 60-2470 POWER SUPPLY AND THREE 25SU3-2000 AMPLIFIERS

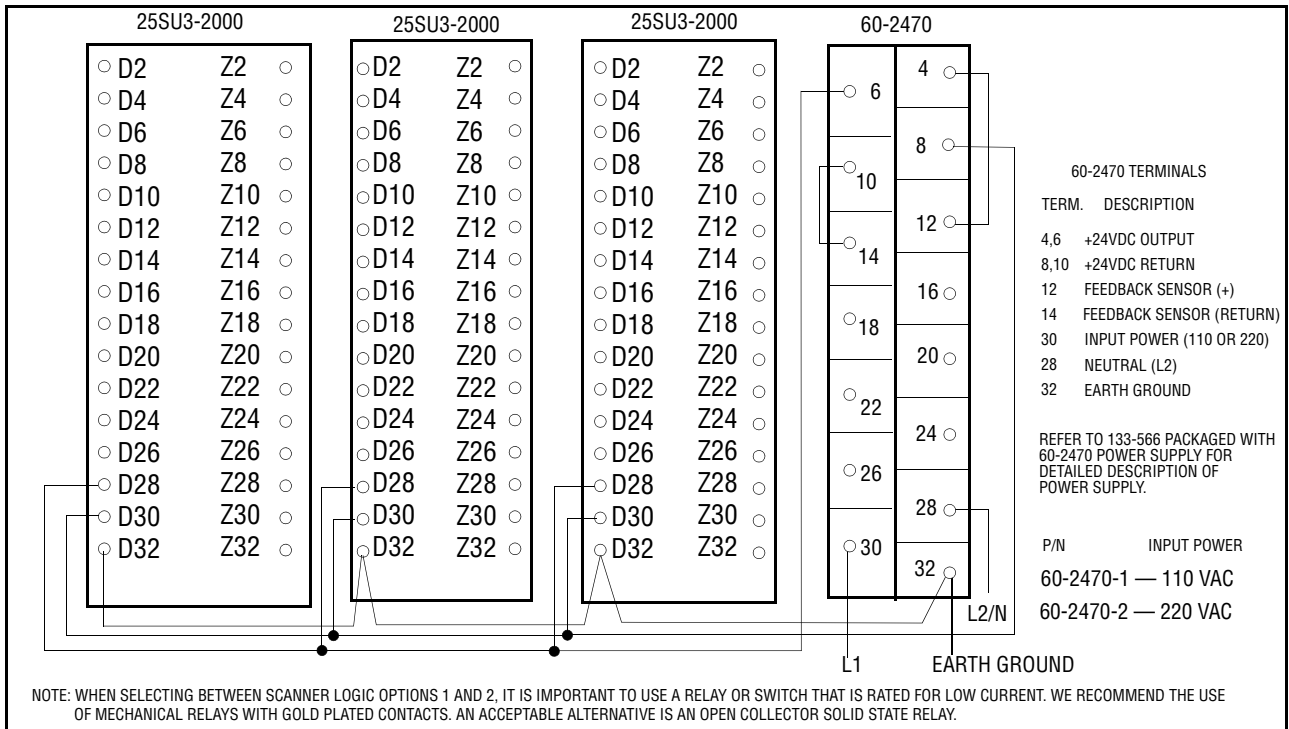

FIGURE 9. SCANNER WIRING DIAGRAM: 25SU3-2000 AMPLIFIER 45RM4/45FS1/45UVFS1 WIRING COMBINATION^{1, 2}

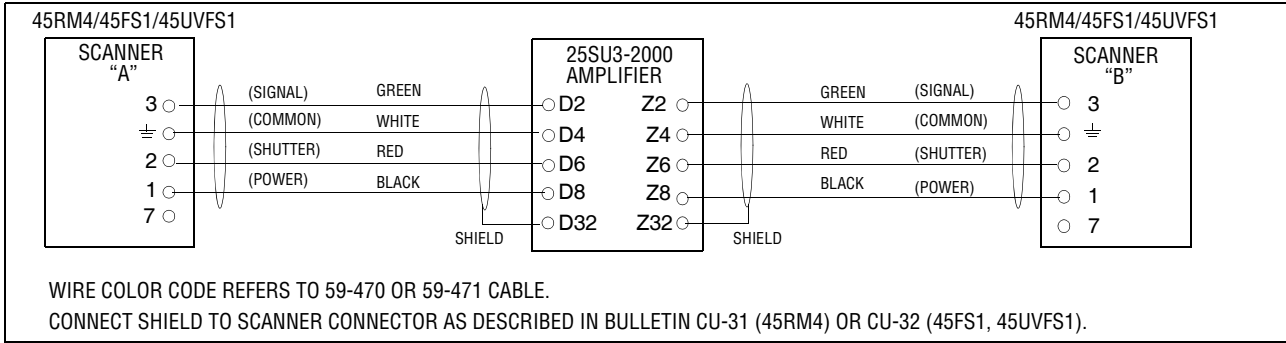

FIGURE 10. SCANNER WIRING DIAGRAM: 25SU3-2000 AMPLIFIER 19UVPS/45RM1, 45RM2 SCANNER WIRING COMBINATIONS¹

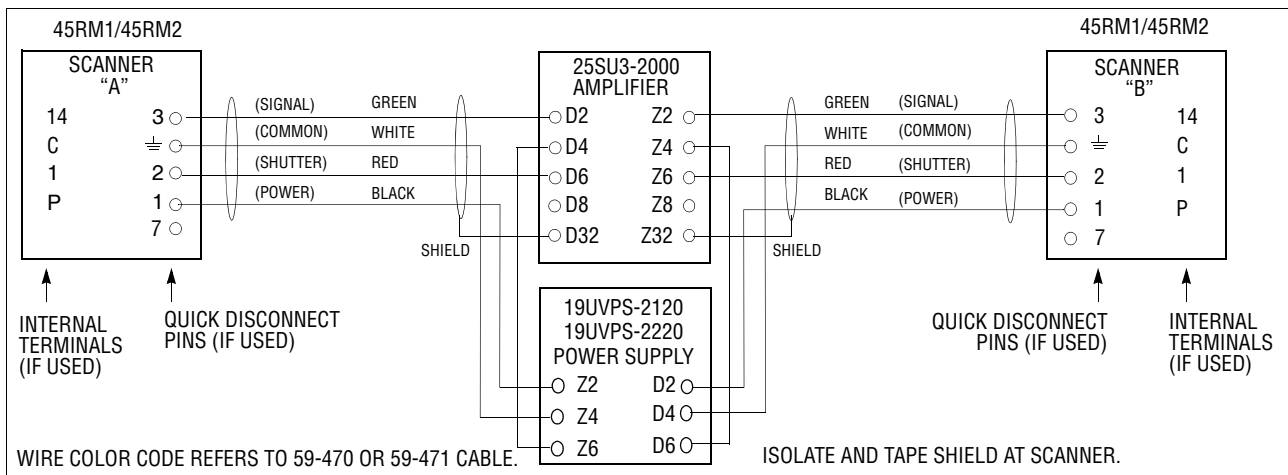
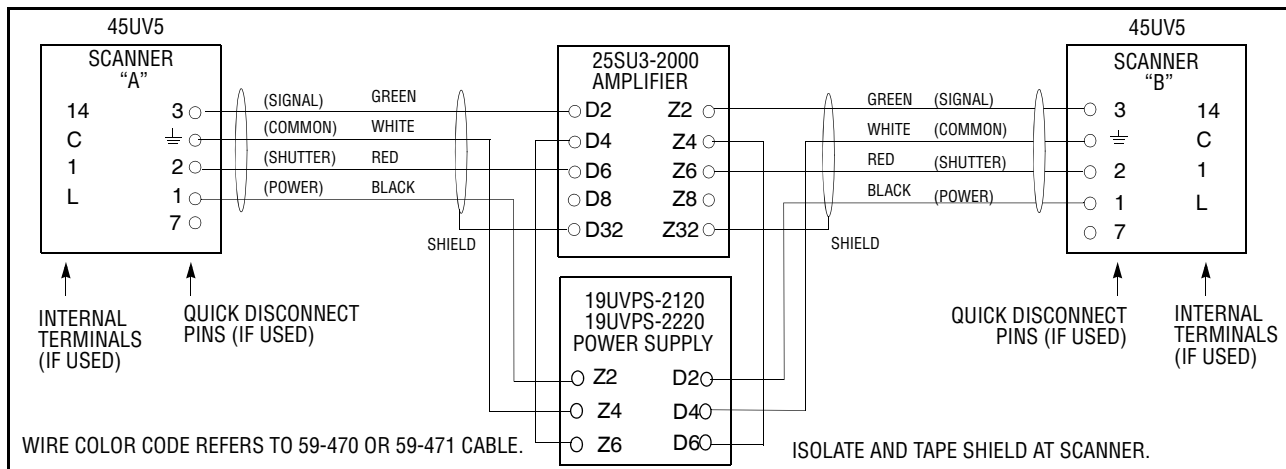

FIGURE 11. SCANNER WIRING DIAGRAM: 25SU3-2000 AMPLIFIER 19UVPS/45UV5 SCANNER WIRING COMBINATIONS¹



¹. If only one scanner is used, connect as scanner "A."

². Wire color code refers to 59-470 or 59-471 cable. Cable 59-221 (OBSOLETE) had the same color code, but only the green wire was shielded.

FIGURE 12. 19MPS-2000 power supply to two (2) 25SU3-2000 amplifiers, each amplifier with one low voltage scanner (45RM4, 45FS1, or 45UVFS1) and one line voltage scanners (45RM1, 45RM2, or 45UV5).

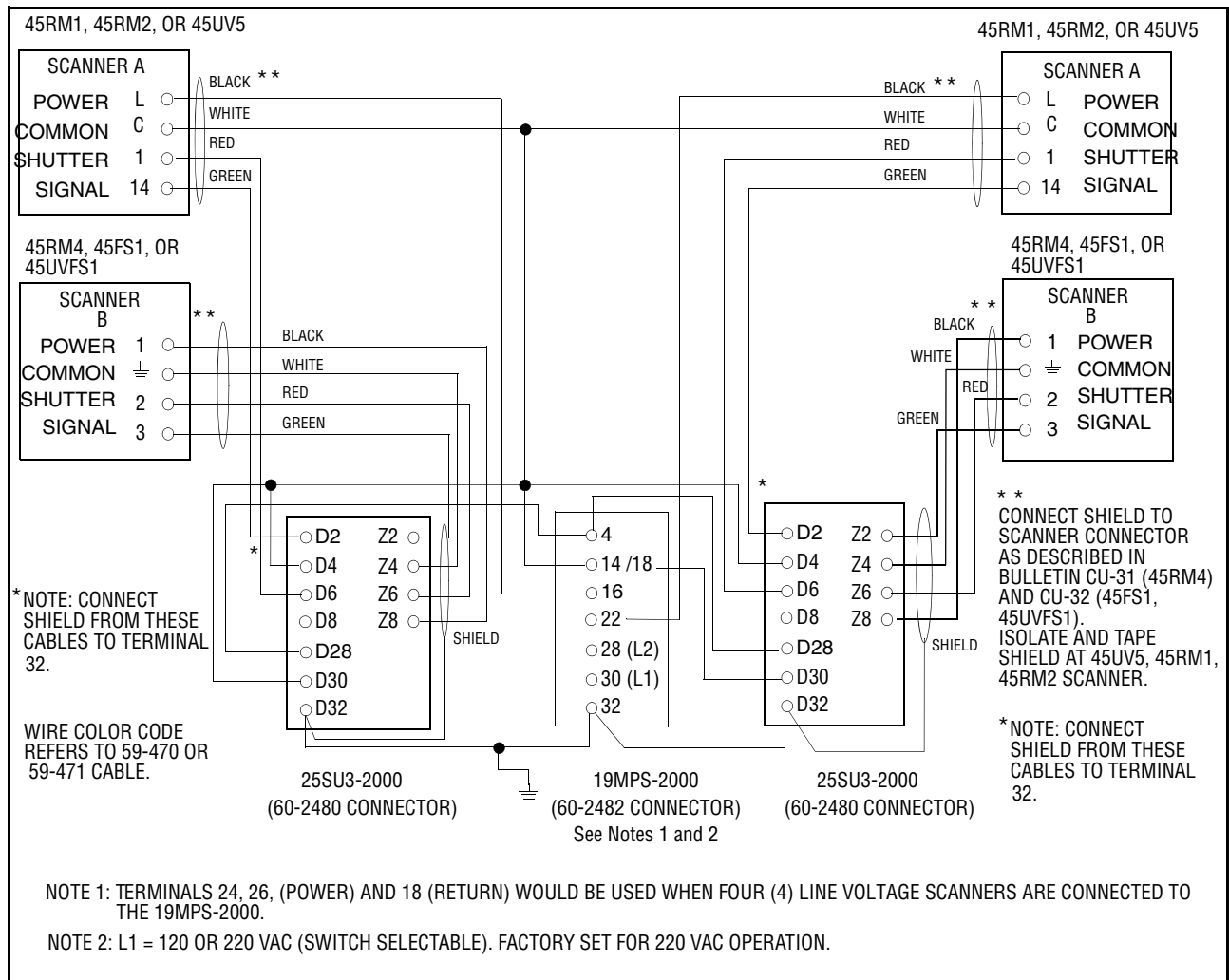







NOTICE

When Fireeye products are combined with equipment manufactured by others and/or integrated into systems designed or manufactured by others, the Fireeye warranty, as stated in its General Terms and Conditions of Sale, pertains only to the Fireeye products and not to any other equipment or to the combined system or its overall performance.

WARRANTIES

FIREYE guarantees for *one year from the date of installation or 18 months from date of manufacture* of its products to replace, or, at its option, to repair any product or part thereof (except lamps, electronic tubes and photocells) which is found defective in material or workmanship or which otherwise fails to conform to the description of the product on the face of its sales order. **THE FOREGOING IS IN LIEU OF ALL OTHER WARRANTIES AND FIREYE MAKES NO WARRANTY OF MERCHANTABILITY OR ANY OTHER WARRANTY, EXPRESS OR IMPLIED.** Except as specifically stated in these general terms and conditions of sale, remedies with respect to any product or part number manufactured or sold by Fireeye shall be limited exclusively to the right to replace or repair as above provided. In no event shall Fireeye be liable for consequential or special damages of any nature that may arise in connection with such product or part.



FIREYE
3 Manchester Road
Derry, New Hampshire 03038 USA
www.fireeye.com

CU-34E
NOVEMBER 30, 2011
Supersedes January 26, 2007