



FIREYE Inc.
3 Manchester Road
Derry, NH 03038 USA
Tel: (603) 432-4100
Fax: (603) 432-1570

INSTALLATION INSTRUCTIONS 133-677 TERMINAL BLOCK WIRING BASE

Used with BurnerLogix Y type only

FLAME SAFEGUARD and BOILER CONTROL

Wiring base part number **60-2812-1** offers a closed wiring compartment suitable for mounting outside of a cabinet. Knockouts are located along the bottom surface of the wiring base. Wiring base **60-2814-1** offers an open wiring base accessible from the bottom and suitable for mounting inside a cabinet. Both wiring base styles contain a terminal block inside the wiring compartment and is located outside of the control mounting area. Access to the compartment is gained by loosening and NOT removing the screws used to secure the housing compartment cover. The terminal block allows easy troubleshooting access to all BurnerLogix control terminals without the need to remove the control from the base. As shipped, all knockouts on the **60-2812-1** are in place and can be easily removed with either a screwdriver, used as a chisel or a blunt force of greater than 10 lbs. The wiring base can be mounted using either a din rail or direct mounted to a back plate using up to #10-32 screws. The mounting location for the din rail is along the horizontal center line. The mounting information is detailed as follows:

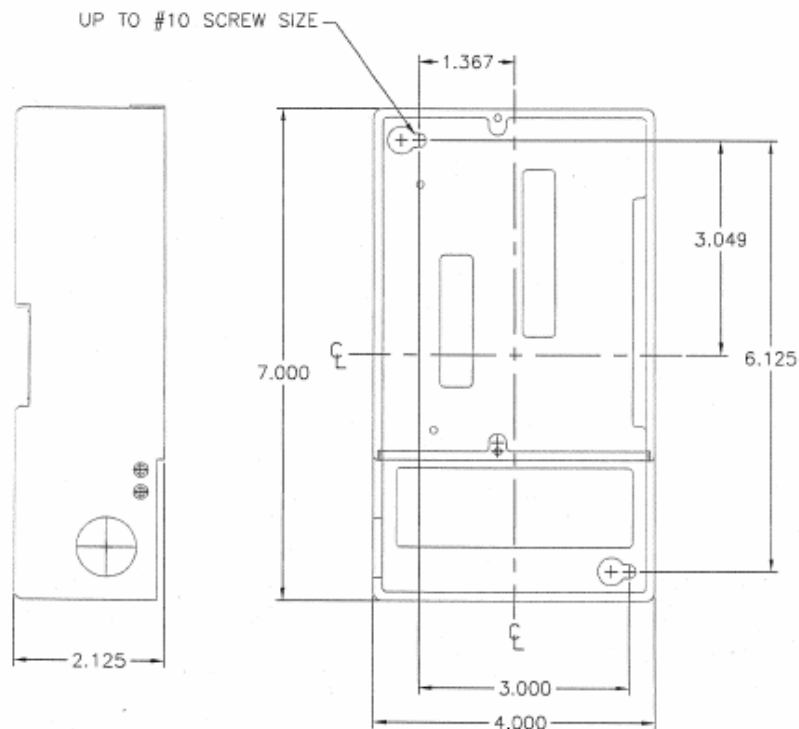

Ensure that electric power is turned off!

WARNING: Installer must be trained and qualified. Follow the burner manufacturer's instructions. Controls require safety limits utilizing isolated mechanical contacts. Electronic limit switches may cause erratic operation and should be avoided.

CAUTION: Refer to SN-100 for recommended grounding techniques. Be aware that power to some interlocks (operating controls, air flow switches, modulating circuits, etc.) may be derived from sources other than what is controlling the BurnerLogiX.

Terminal No.	Wire Color	Type	Description	Rating
L1 (Hot)	Black		Line voltage supply	120 VAC (+10%,-15%), 50/60 Hz
L2 (Neutral)	White		Line voltage common	
EARTH	Green	Ground		
S1	Red/Wht		Scanner Input	300 VAC, 3 mA
S2	Blu/Wht		Scanner Input	300 VAC, 3 mA
A	Red	Output	Alarm	120 VAC, 1 A pilot duty
M	Brown	Output	Combustion Blower	120 VAC, 9.8 FLA, 58.8 LRA
3	Yellow	Input	Operating Control	120 VAC, 1 mA
13	Orange	Input	Fuel Valve End Switch, Pre-Ignition Interlock	120 VAC, 1 mA
P	Gray	Input	Running Interlock	120 VAC, 1 mA
D	Wht/Brn	Input	Low Fire Start Switch	120 VAC, 1 mA
8	Wht/Gry	Input	Open Damper Proving Switch	120 VAC, 1 mA
W	Wht/Orn	Output	Delayed Main Valve	See Table
5	LT Blue	Output	Ignition / Pilot Valve	See Table
6	Tan	Output	Pilot Valve	See Table
7	Violet	Output	Main Fuel Valve	See Table
16	DK Blue	Input	Pilot Valve Hold	120 VAC, 1 mA
21	Pink	Input	Start Input	120 VAC, 1 mA
10	Wht/Red	Output	Modulator Common	120 VAC 75 VA
12	Wht/Yel	Output	Modulator Low Fire	120 VAC 75 VA
X	Wht/Blue	Output	Modulator High Fire	120 VAC 75 VA
11	Wht/Grn	Output	Modulator Auto	120 VAC 75 VA
22	Wht/Vio	Input	Remote Reset	120 VAC, 1 mA
23	Brn/Wht	Input	Spare 2	120 VAC, 1 mA

Combination No.	Pilot	Main	Ignition	Delayed Valve
1	C	E	No Load	No Load
2	B	E	No Load	No Load
3	No Load	E	No Load	B
4	E	E	A	No Load
5	No Load	E	A	E
6	D	E	A	No Load
7	D	D	A	D
8	No Load	D	A	No Load
Composition of each Combination				
A	B	C	D	E
4.5 A Ignition	50 VA Pilot Duty plus 4.5 A Ignition	180 VA Ignition plus motor valves with: 660 VA inrush, 360 VA open, 250 VA hold.	2 A Pilot Duty	65 VA Pilot Duty plus motor valves with: 3850 VA inrush 700 VA open, 250 VA hold

MAXIMUM CONNECTED LOAD NOT TO EXCEED 2000 VA